

The Complete Car Refinish Program



German Engineering

Spray Guns | Cup Systems | Breathing Protection | Air Filtration | Accessories



Perfect Paint Application

The new SATAjet® X 5500. Revolutionary. Efficient. Silent. Consistent.

State-of-the-art paint systems and the latest application recommendations open up new possibilities, but also pose new challenges for professional painters. The SATAjet X 5500 featuring the new X-nozzle system now defines a new application standard for the future.

The concept of this nozzle system is easy and straightforward to understand: Both proven application technologies – HVLP and RP – remain available, but now each of them offer the additional choice between "I" and "O"-nozzle sets. In line with the increasing nozzle sizes within each of the respective technology (HVLP / RP), the material flow rate increases too with constant increments, which means that the spray fan size and width remain unchanged across the entire nozzle spectrum. In essence, end-users can now rely on a transparent and consistent system which offers them clear and well-structured application options.

The **"I"-nozzles** produce a parallel spray fan pattern with a minimal dry zone and a drier center which is ideal for painters preferring a **reduced application speed** and maximum application control during the painting process. The **film build per coat** in comparison to an "O"-nozzle of the same size is **slightly reduced**.

- Parallel spray fan with minimal dry zone
- Improved control during the coating process
- Reduced film build per coat compared to the nozzle set currently in use or the "O"-nozzle

"O"-nozzles do have an oval-shaped spray fan pattern with a larger dry zone and a wet core to accommodate **increased application speed** at the expense of slightly less application control during the painting process. The **film build per coat** in comparison to an "I"-nozzle is **slightly higher**.

- Oval-shaped spray fan with larger dry zone
- Wet core for increased application speed
- Film build per coat slightly higher compared to the "I"-nozzle

*Spray gun part numbers are in the back of the brochure

SATA® adam 2™



To upgrade non-digital spray guns to "DIGITAL" – the version for retrofitting the **SATAjet X 5500, SATAjet 5000 B Standard and SATAjet 5000 B PHASER** without integrated digital pressure gauge. Ensures correct setting and display of the gun inlet pressure for highest reproducibility.



SATA adam 2 chrome complete,
(fits 5000 series only) **Order No. 211557**
SATA adam 2 black complete,
(fits 5000 series only) **Order No. 1031715**

Order No. 211565 each, (dock only,
fits 5000 series only)
Order No. 211573 Pk of 2, (dock only,
fits 5000 series only)

SATAjet® X 5500 Maintenance Set



Just what you need to tune-up your spraygun

- Handy "slimmed-down" maintenance sets
- Each set contains: Air cap ring seal, sealing element for fluid tip, air piston packing & holder, air piston head and rod, needle packing and holder, seals, spring, screws.

Order No. 1050674X



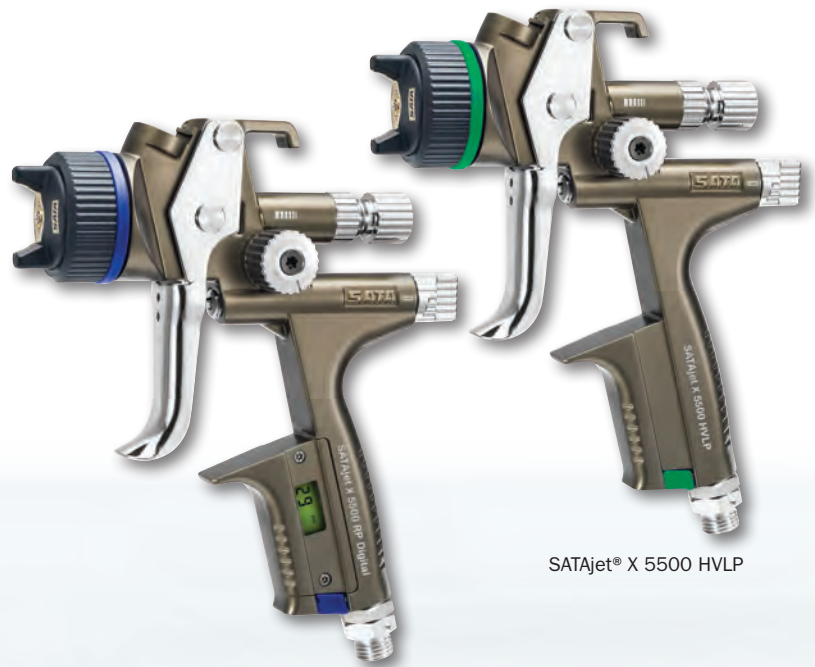

SATAjet® X 5500 HVLP

SATAjet® X 5500 RP®



PRODUCT BENEFITS



- Revolutionary: The X-nozzles are taking atomization to a whole new level
- Noticeably quieter: Whispering nozzle™ due to optimized air flow geometry, reduced noise level in the relevant sound frequency ranges
- Individual: Matches each application requirement, such as specific characteristics of the paint system, climatic conditions and application method (application speed/application control)
- Precise: Optimized material distribution for enhanced spraying uniformity and atomization with both spray fan shapes
- Low maintenance: No air distribution insert required, ensuring a much easier and faster cleaning process
- Consistent: Constant fan size across the entire nozzle spectrum (within the range of each respective atomization technology) with linear increases of the material flow rate
- Efficient: The optimized atomization concept enables to realize considerable material savings using the same application method as before



Supreme flexibility – The SATAjet® 5000 B

PRODUCT BENEFITS

- Optimized nozzle concept for highest possible versatility
- Ergonomically shaped gun handle
- Pearlodized™ surface is a technical enhancement of the "pearlchrome" surface to further improve corrosion resistance as well as ease of cleaning and maintenance
- Easy to adjust control elements
- Safely positioned trigger sleeve – for easy, safe and quick insertion of the paint needle
- Identical compact-size gun handle for non-digital and digital spray guns
- Optimized round / flat fan control with half-turn only
- RP: 10.2 cfm at 29 psi; HVLP: 15.2 cfm at 29 psi



Versatility

The premium spray gun SATAjet 5000 B sets quality standards. Being extremely versatile in terms of application distance and inlet pressure, this established, high-performance spray gun has a well proven track record. Painters have the ability to set pressure and distance as required by the paint to be applied, the climatic conditions and the work method – to achieve perfect finishes.

Ergonomics at its finest

The design of the **SATAjet 5000 B** has been created by the experts at the Porsche Design Studio who have translated pure functionality into aesthetic form together with the specialists at SATA. Due to the optimized shape of the gun handle, the spray gun fits perfectly in the palm of the hand. In addition, the gun handle of the digital version is identical in size to the standard model which makes it the perfect spray gun for all painters, regardless of the size of their hands.

SATAjet® 5000 B Maintenance Set

Just what you need to tune-up your spraygun

- Handy "slimmed-down" maintenance sets
- Each set contains: Air cap ring seal, sealing element for fluid tip, air piston packing & holder, air piston head and rod, needle packing and holder, seals, spring, screws, air distribution ring & puller.

Order No. 1050674



*Spray gun part numbers are in the back of the brochure



SATAjet® 5000 B RP®



SATAjet® 5000 B HVLP
(DIGITAL version)



RP version approved by SCAQMD and EPA, meets rule 40, part 63, HHHHHH



SATAjet® 5000 B PHASER

Transforms work into wonderment

An exclusive spray gun that has been developed in cooperation with the Porsche Design Studio. Exceptional optics, exceptional materials and an exceptional design concept – for exceptional projects.

- Combining a unique look with high-quality materials
- SATAjet® 5000 B nozzle technology
- Fast coverage and film build
- Using less paint
- Exceptional high transfer efficiency
- Flexible gun distance
- Durable for solvent or waterborne paint
- RP: 10.2 cfm at 29 psi; HVLP: 15.2 cfm at 29 psi



Top Coat Spray Guns for Perfect Finishes

SATA high performance spray guns are used for the application of top coat materials in car refinishing, **with their nozzle sets being designed for the application of modern base and clear coats from all leading paint manufacturers** and fine-tuned during the final quality inspection process at SATA to ensure that your paint jobs meet highest demands in terms of **brilliance, desired color effects, uniform material distribution, gloss and color match.**

- SATA high performance spray guns are made of forged aluminium and finished with a high-quality chrome plating
- With their fluid tips and paint needles being made of stainless steel, they can be used for the application of both solvent-based and waterborne paints
- Round/flat fan control and air micrometer are standard features
- The gun handle as well as all control elements are ergonomically formed for perfect gun control
- Robust in their design, SATA spray guns are low in weight
- The spray guns are easy to clean and maintain, due to self-adjusting seals, paint needles protected from paint mist, sturdy air cap threads and short material passages
- The inlet pressure can be precisely adjusted and controlled either with an integrated or a retrofit electronic pressure gauge



SATAjet® 4000 B

Shape and function blending into one unique experience

The perfect complement or alternative to the SATAjet 5000 for every bodyshop accomplishing car and utility vehicle repair or full paintings.

- A uniform and perfectly shaped spray fan allows rapid application speed and brilliant finishes
- Lightweight and pleasantly ergonomic spray gun
- **Optional:** SATAjet 4000 B DIGITAL with integrated electronic inlet pressure adjustment
- RP: 10 cfm at 29 psi; HVLP: 15.2 cfm at 29 psi

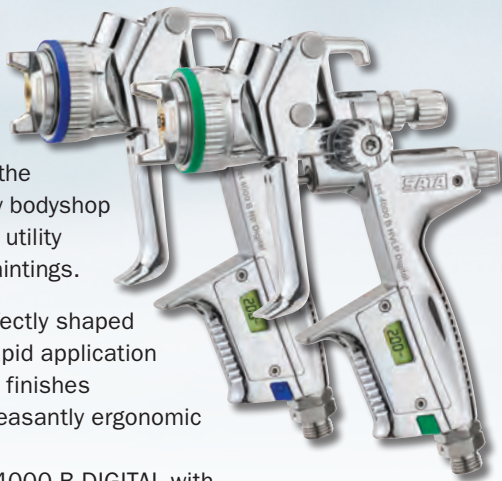

SATAjet® 4000 B Maintenance Set

Handy "slimmed-down" sets

- Each set contains: Air cap ring seal, sealing element for fluid tip, air piston packing & holder, air piston head and rod, needle packing and holder, seals, spring, screws, air distribution ring & puller.

Order No. 1047837



SATAMinijet® 4400 B

Brilliance in Miniature

Compact, lightweight gravity flow cup spray gun for small surfaces and areas of difficult access as well as for custom paintings.

- Easy to clean, corrosion-resistant pearlodized™ surface
- Special "SR" nozzle sets for spot repairs
- This spray gun allows the application of all modern paint systems - including waterborne
- Large QCC cup connection for all cup sizes
- RP: 7.0 cfm at 36 psi; HVLP: 4.1 cfm at 20 psi

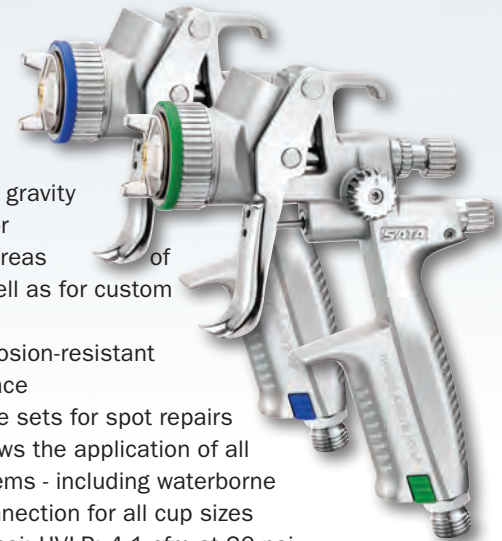

*Spray gun part numbers are in the back of the brochure

SATAjet® 1000 K



The lightweight universal pressure-fed gun for large surface applications

- Allows connection to all sorts of material supply systems, such as pressure pots, double diaphragm pumps and central paint supply systems
- Suitable for the application of various materials – waterborne or solvent-based
- Sturdy, easy clean surface
- Special air flow at the air cap horns reduces overspray settling at the air cap
- **Optional:** fluid tip and paint needle with lifetime prolonging surface
- RP: 14.5 cfm at 35 psi; HVLP: 19 cfm at 35 psi

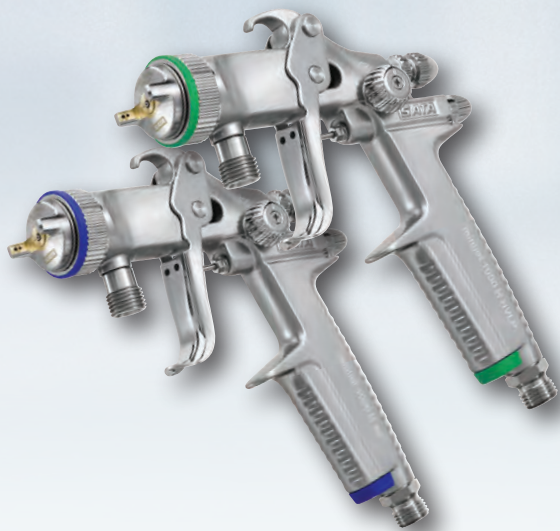
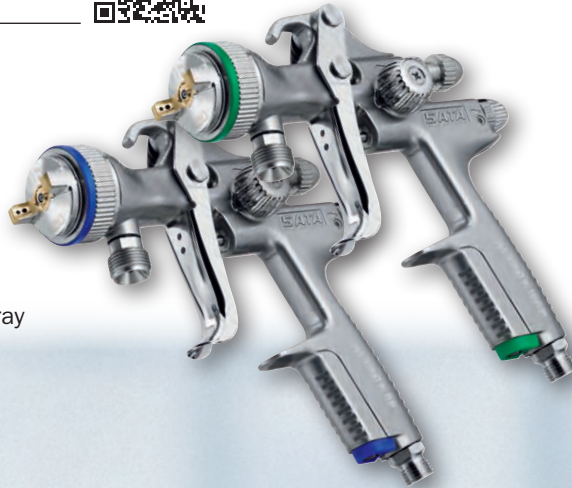

SATAminijet® 1000 K



The compact industrial gun

Compact, reduced size spray gun with full size attitude! Great for specialty applications.

- Small to large panels and spot repairs of existing finishes
- Excellent for small objects or hard to reach areas
- Designed for less hand fatigue and longer continuous work
- Also available in siphon cup version, SATAminijet H, 1.4 nozzle
- Both HVLP and RP versions are available
- RP: 7 CFM at 36 psi; HVLP: 4.2 CFM at 29 psi



SATAjet® 3000 K



The pressure-fed gun for large surface applications

Painting entire utility vehicles requires pressure fed spray guns.

- High surface efficiency due to material supply from pressure tanks or via double diaphragm pumps
- Wide, smooth and homogeneous spray fan for perfect finishes at high application speed
- Extremely sturdy version with axial round/flat spray control
- **Optional:** fluid tip and paint needle with lifetime prolonging surface
- RP: 15.5 cfm at 36 psi; HVLP: 20 cfm at 36 psi

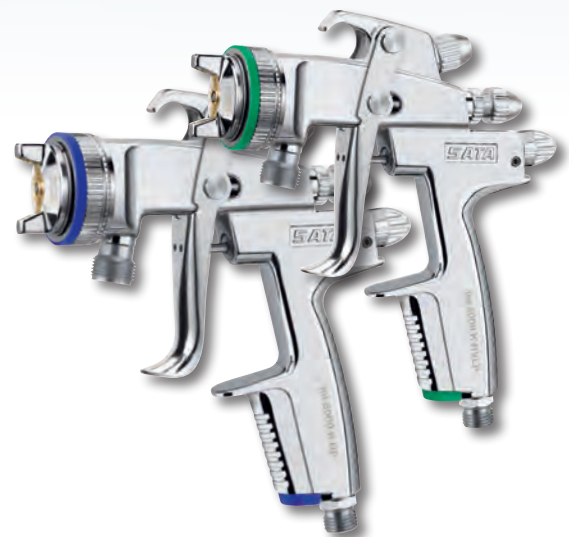

*Spray gun part numbers are in the back of the brochure

SATAjet 1500 B SoLV – The solvent solution

SATA extends an invitation to technicians using solvent paint products who would like to take advantage of SATA's quality and reliability at an affordable price. For those who have or have not used SATA spray guns before, step-up and give the SATAjet 1500 B SoLV a try.

The SATAjet 1500 B SoLV in HVLP and RP provides fine finishes with cost saving transfer efficiency, keeps the required wetting using today's **Low VOC exempt solvent basecoat** or the more traditional **National Rule solvent basecoats**. The SATAjet 1500 B SoLV is also a good choice for **clearcoat** appearance, while meeting transfer efficiency and profitability expectations.

The nozzle system of the SATAjet 1500 B SoLV meets the demands for topcoat applications and delivers even material distribution throughout the entire pattern. It offers to solvent and **Low VOC application** the flexibility painters expect from a SATA gun. The balanced design provides comfort and ergonomics, and the easy-to clean durable surface of the spray gun will work with any solvent-based material.



RP version approved by SCAQMD and EPA



PRODUCT BENEFITS

- Designed for Full System Application: solvent-based basecoats, either **Low VOC** or **National Rule** as well as sealer and **clearcoat**
- Nice-sized, even spray pattern
- Wide air pressure range from 7 – 29 psi. HVLP compliant 26 psi, RP compliant 29 psi
- Fast working speed
- Smooth anodized spray gun body in a modern blue color tone
- Excellent value spray gun



Pressure Suggestions*	HVLP	RP
National Rule Solventborne Basecoat	24-26 psi	24-28 psi
Traditional Clearcoats (Above 14 seconds DIN 4)	22-26 psi	22-26 psi
Low VOC Solventborne Basecoat	18-24 psi	18-26 psi
Low Viscosity or Extra Fast Air Dry Clearcoats (Under 14 seconds DIN 4)	20-24 psi	20-24 psi

*The above inlet air pressures are to be considered a starting point when spraying that type of product.



Watch 1500 SoLV demonstration video on YouTube

Technical Details

	HVLP	RP
Operating range	7 - 26 psi	7 - 29 psi
Air consumption at 26 psi air inlet pressure HVLP compliant 26 psi max pressure	12.4 cfm	10.2 cfm

*Spray gun part numbers are in the back of the brochure

SATA dry jet 2 – Waterborne Drying System

Globally, the use of waterborne paint is increasing. However, depending on climatic conditions, waterborne may take longer to flash off than solvent based materials. Slower drying can result in greater time in the spray booth and reduction in productivity. The new SATA dry jet 2 blower guns help reduce flash-off and cycle times significantly.

Operating mode

The SATA dry jet 2 utilizes the Venturi principle – in addition to the compressed air feeding the system, a multiple of ambient air is drawn in, turning, 8.2 to 9.35 CFM of compressed air into approximately 95 CFM that immediately serves to accelerate the drying process. The recommended inlet pressure is 29 to 35 psi. Essential for a reduced flash-off time is not only a large air volume, but also an even, preferably wide, air flow which is produced in the injector zone of the new round fan nozzle.



SATA® dry jet™ 2



This practical, lightweight blow gun makes quick work of drying waterborne material. A special nozzle design multiplies air volume from ambient air using the Venturi injection principle. An air intake filter prevents contamination of the paint. Air consumption is only 9.5 cfm at 35 psi. The CFM is magnified x10 to give a 92.35 CFM output.

Order No. 217489

SATA® dry jet™ 2 Stand



With two dry-blower guns. Each individual blow gun can be directed independently at the painted object. The stand offers many advantages including unattended use and it may be placed in any position. Adjustable in height from 11.8 to 74.8 inches and 31.5 inches in width.

with 2 dry-blower guns **Order No. 223008**

3rd gun connection with dry-blower gun

Order No. 86140

Econo-Jet Blow Gun Stand

This economical mobile stand is offered as a package with two guns. Adjustable gun height, with 360° swivel or tilt. Supplied with high flow connections and tubing for maximum performance of the blow gun.

Order No. 720640



SATA® adam®/adam 2 mini™ SATA® adam® 2 black

Turns a non-digital spray gun into a "DIGITAL" - for retro-fitting SATA spray guns without integrated digital pressure gauge. Ensures correct setting and display of the gun inlet pressure for highest color match precision.



SATA adam 2 mini dock
Order No. 160861



SATA adam 2 dock
Order No. 160788 ea.



SATA adam 2,
Order No. 160796
pack of 2
For SATA full size
except SATAjet 5000
SATA adam 2 U air
micrometer G 1/4 w/dock
Order No. 195230



SATA adam 2
chrome
display only
Order No. 160697



SATA adam 2 black
display only
Order No. 1031658
for all SATA spray guns



SATA adam 2 chrome mini
with dock and display
Order No. 160887



SATA adam 2 black mini
with dock and display
Order No. 1031674



SATA adam 2 U
chrome
with dock and display
Order No. 195222

SATA adam 2 U black
with dock and display
Order No. 1031731

SATA dock only
Order No. 195925

See pg 2 - SATA adam 2 for the SATAjet 5000 series only

SATA® trueSun™ – the Daylight Solution

The selection of the correct color shade for refinishing a vehicle requires a source of light that preferably reproduces the entire color range of visible light (daylight) as accurately as possible.

The SATA® trueSun™ LED lamp which was especially designed for this purpose allows a quick and easy professional color shade evaluation and identification within the body shop. When selecting the right daylight lamp there is no room for compromise, any rework caused by an incorrect color identification is an expensive mistake with high rework costs. Even avoiding one rework covers the purchase price for this high quality product.



Watch the video at www.satausa.com



PRODUCT BENEFITS

- Near perfect daylight conditions on any color shade, no need to move the project outside
- Uniform distribution of the light intensity across the entire light cone
- Battery life approximately 70 minutes at full light intensity, lasting for an entire days production in most shops
- Uniform light intensity – unaffected by the battery charge level
- Fast charging cycle time of approximately 50 minutes
- Adjustable light intensity
- Built-in charge level display
- Near daylight reproduction of color pigments
- Coating flaws such as mottling and poor hiding can be easily detected



SATA® trueSun™

including battery
charger and battery
Part No. 1012129

Storage Case

including foam inlay
Part No. 1013094

foam inlay only
Part No. 1013151

*Part numbers for trueSun accessories in back of the brochure

Uniform distribution of the light intensity

The uniform light distribution across the entire illuminated area simplifies selecting the right color shade. The light intensity can be adjusted via the sliding control on the back of the light.

The light intensity remains the same throughout the entire battery life, which removes aggravating interruptions during the color match process.

Daylight lamps used for color shade determination, by comparison



Light cone of the SATA® trueSun™
at maximum light power, uniform distribution of the light intensity from edge to edge – color temperature is neutral

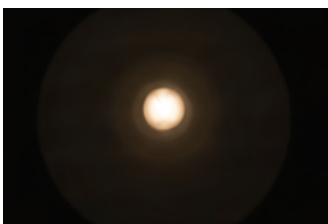

Example high quality flashlight manufacturer A
Very small, non-uniformly illuminated surface, strong yellow coloration

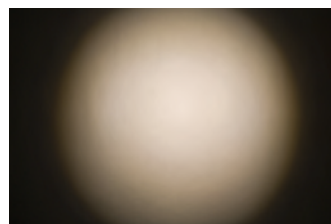

Example daylight lamp manufacturer B
Uniform distribution of the light intensity, but very strong yellow coloration.

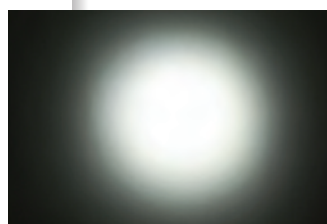

Example daylight lamp manufacturer C
inconsistently illuminated surface, edges appear greenish/bluish

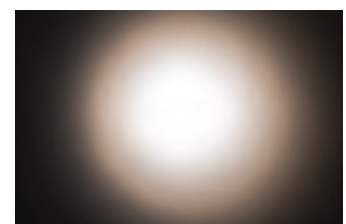

Example daylight lamp manufacturer D
inconsistently illuminated surface, edges appear reddish.

KNOWLEDGE

Color temperature

The color temperature of a light source is indicated in Kelvin (K). The temperature has influence on the optic impression. Therefore, it should be in a neutral range when defining the color shade. The daylight (sunlight) at noonday sun has a color temperature of approximately 5,500 – 5,800 K.

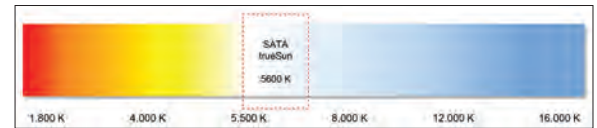

CRI value

The CRI value (Color Rendering Index) indicates the quality of the color reproduction of a light source. This value is composed of the average value of 14 defined reference colors.

Daylight CRI value: 100

SATA® trueSun™ CRI value: 97



Spectral distribution – daylight & SATA® trueSun™

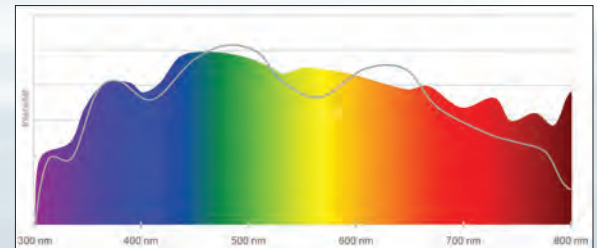

Daylight SATA® trueSun™

Lux (lx)

Lux indicates the illumination intensity of a light source.

Daylight lux value: up to 100,000 lx

SATA® trueSun™ lux value: 22,000 lx at 11.8 inch distance

TECHNICAL DATA

LED light

Total weight	approx. 1.04 pounds
CRI value	97
Color Temperature	approx. 5,600 K
Light intensity (lux)	22,000 lx at 11.8" distance
Operating temperature LED lamp	32°F - 104°F
Storage temperature LED lamp	-4°F - 176°F
Battery life at full light intensity	approx. 70 min.
Battery operating time	approx. 70 min.

WARNING: The use or storage of the SATA® trueSun™ LED lamp as well as the batteries and chargers in explosive or inflammable areas is prohibited.

Design and Airbrush Guns



To paint creative, fancy motives, many artists from the airbrush scene prefer SATA design guns. They are especially suitable for creating fine dots, delicate lines and contours. Different models are available to suit your specific application needs.



Order No. **S004B**
SATAgraph 4 B, Gravity feed



Order No. **S004S**
SATAgraph 4 S, Side feed

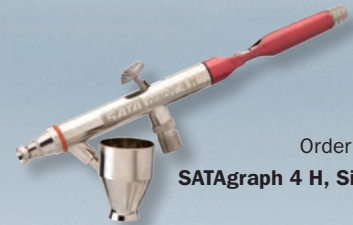

Order No. **S004H**
SATAgraph 4 H, Siphon Feed

"German Engineered, Made in America"

SATA® graph™ 4



- SATA super grip trigger. Has a unique forward cut trigger with cross teeth giving a comfortable none slip grip.
- Crosscut reversible air cap tip. Crosscuts allow air to flow away from tip when close to surface, painting with less turbulence.
- Teflon coated trigger and rocker arm. This creates a super smooth trigger pull for better control.
- Single piece trigger. No more going blind trying to put the trigger in the gun. More durable and less costly.
- Trigger set knob at rear of the gun allows you to set the trigger pull at a certain position to control paint flow.
- Solvent proof "O" rings on front and inside of airbrush.
- Competitively priced. The most affordable airbrush of this quality.
- Very affordable replacement tips and needles.

SATA® graph™ 4 Design Set

- 3 gun kit includes all 3 SATA-graph 4 airbrushes, S004B, S004S and S004H,
 - also included is a (1) S0323, 3/4 oz glass jar with siphon lid, (1) S039, 1 oz. glass cup with side feed lid, (1) S045, 6 ft braided hose with quick disconnect, (3) Quick connect plug/fittings, female, (1) foam padded case with handle
- Order No. **S004HBS**





SATA® graph™ 1

For beginners:

- With double action system for separate air and material control to achieve special effects
- Versions with gravity flow cup or suction cup



SATA® graph™ 3

For professionals:

- Features similar to SATAgraph 1, however, with additional removable needle cap to allow drawing finest lines
- Material flow control
- Four nozzle sizes available
- Versions with gravity flow cup or suction cup



Dan-Am Mini Muscle

Air Brush Compressor

The Dan-Am mini compressor is a rugged and compact portable unit that is ideal for the airbrush artist.

- 1.6 hp
- 1 gallon storage tank
- Twin cylinder
- Max 80 psi
- Regulator w/water trap

Order No. 677600



Glass cups for SATAminijet 4400 B, SATAminijet 3000 B and SATAjet 20B

Glass Plug-in cups
25ml, pack of 5

Part No. 53033



Glass Plug-in cups w/GCC & threaded adapter SATAminijet 3000 (and earlier) and 20B 25ml, pack of 5 cups

Part No. 125963



Glass Plug-in cups w/GCC adapter SATAminijet 4400 B, and 3000 B 25ml, pack of 5 cups

Part No. 200238



SATAjet® 20 B

designed for use in all areas of creative painting:

For all kinds of art brush applications including graphic design, automotive custom painting, model making, artwork and calligraphy - the results are simply outstanding.

- Airbrush with round fan in exceptional spray gun design ergonomically shaped for fatigue-free working
- Durable and low maintenance
- Material flow control
- Low maintenance due self-adjusting seals
- Flexible air supply - inlet connection available at the base and at the rear of the gun.
- Large range of round spray nozzles



*Part numbers are in back of the brochure

SATAjet® 20 B Design Set

- In addition to the SATAjet 20 B 0.5, and spare nozzle set 0.2, air micrometer, PVC air hose 3m, glass jar 25 ml with blank lid, cleaning and seal kit, spray gun stand.
 - Specify nozzle size
- Order No. 90381



SATAminijet® 4400 B Design Set

- Perfectly suitable for graphic designs, automotive custom painting, artwork and calligraphy as well as spot repair.
 - In addition to the spray gun with nozzle size 1.0, the fully equipped SATA design set also contains all necessary accessories
- Order No. 198382



Special Spray Guns for Primer, UV Primer, Filler and Sealer Materials

Prep materials such as primer, UV primer, filler and spray putty fulfill an important function within the paint process. To economically apply these primer materials, the use of the SATAjet 100 B F and B P are recommended. The material is applied with extremely low over spray allowing little masking efforts. Together with the use of SATA RPS multipurpose cups, SATAjet 100 B F and B P spray guns are the perfect solution for these special requirements.



SATAjet® 100 B F™

RP® and HVLP - for primers and fillers

Primer, sealer and filler application with little overspray saves paint material and reduces masking effort. A smooth material distribution reduces subsequent sanding efforts. Already with an inlet pressure of 7.25 psi, the spray fan can be flexibly and precisely adjusted even to small spot repair areas.



- Sturdy spray gun with anodized spray gun body
- Fully equipped with round/flat fan control and material flow control as well as air micrometer
- SATAjet 100 B RP 1.1 is an excellent choice for UV primer
- Comfortably lightweight and ergonomically optimized spray gun
- Little cleaning and maintenance
- Versatile use due to four different RP and HVLP nozzle sizes



SATAjet® 100 B P™

for the application of spray putty

The nozzle set "P" creates high film builds. The sharp-edged spray fan allows precise application.

- Same features as SATAjet 100 B F, however without air micrometer
- The SATAjet 100 B P is an excellent choice for spraying large flake



SATA's UV Spray guns



SATAminijet 4400 RP 1.0 SR
with standard QCC RPS cups
Order No. 198358

Nozzle Set only
SATAminijet 4400 RP 1.0 SR
Order No. 201293



SATAjet 100 B F RP 1.1 UV
with standard QCC RPS cups
Order No. 203125

Nozzle Set only
SATAjet 100 B F RP 1.1 UV
Order No. 182600

*Spray gun part numbers in the back of brochure

DanAm Air

Professional Aluminum Compressed Air Piping System

DanAm Air is lightweight, aircraft grade, powder coated aluminum, which provides clean, dry air up to 232 psi. The reinforced composite Nylon fittings have dual seals, which rest on un-scraped pipe, providing a leak free guarantee. Our Press-to-Connect fittings feature a full bore design for turbulence free air delivery. This quick, instant connection eliminates the need to thread, solder or glue, accounting for far less installation times than traditional copper or black pipe.

SAVE MONEY

EASY TO INSTALL YOURSELF OR HAVE PROFESSIONALLY INSTALLED

Use for new installation, or to expand or modify your current system

- ENERGY EFFICIENT
- EASY TO INSTALL
- Modular design
- Corrosion Resistant
- Leak-free guarantee
- Removable and reusable
- Push-to-connect technology
- Immediate pressurization
- Full bore design
- 1/2" to 6" pipe sizes

***SAVINGS up to 35%** *Savings may vary compared to steel or copper installation!

For a FREE quote call: 800-533-8016

DanAmAir®



SATA® RPS® – The Original.

The safe, refillable cup system for professionals: easy, perfect, economical

SATA RPS (Rapid Preparation System) is the ideal cup system for shops focusing on **perfect finishes and high profitability**. It makes a painter's life much easier, considerably increases productivity and drastically reduces the consumption of cleaning solutions and solvents.



RPS 0.6 Liter

Content: SATA RPS 0.6 l cup, lid and filter
 Order # 1010438 (125 μ, flat) pk of 60
 Order # 1010488 (200 μ plug-in) pk of 60
 Order # 1010545 (200 μ, flat) pk of 60

RPS 0.9 Liter

Content: SATA RPS 0.9 l cup, lid and filter
 Order # 1011973 (125 μ, flat) pk of 40
 Order # 1011981 (200 μ, plug-in) pk of 40
 Order # 1012004 (200 μ, flat) pk of 40

RPS 0.3 Liter Standard

SATA RPS 0.3 l cup, lid and filter.
 Order # 1010389 (125 μ, flat) pk of 40
 Order # 1010397 (200 μ plug-in) pk of 40
 Order # 1010420 (125 μ, flat) pk of 100
 Order # 1010404 (200 μ plug-in) pk of 100

RPS 0.3 Liter for SATAminijet

(minijet 3000 B and earlier)
 Order # 1010553 (125 μ, flat) pk of 60
 Order # 1010561 (200 μ plug-in) pk of 60

RPS Spare Lids

Order # 1013226 (0.6 l & 0.9 l lids) pk of 80
 Order # 1013218 (0.3 l Standard) pk of 60
 Order # 1013234 (0.3 l minijet) pk of 108

CHARACTERISTICS

- Easy to use – only 3 parts
- Constant material flow, helping the painter to achieve perfect coating results just like child's play
- Allows very quick color changes - cleaning becomes almost irrelevant
- The special lid shape ensures complete consumption of the paint contained in the cup
- Large number of mixing ratios (up to 100 variations)
- Fits directly on all SATA spray guns - no adapters required
- Stable cup ensures safe storage of leftover material
- Reduces cleaning efforts and solvent consumption
- Available in the 3 cup sizes 0.3 l, 0.6 l and 0.9 l
- Different strainer types available

PRODUCT BENEFITS

Principal benefits of the original SATA RPS system:

1. The bending cup can be adapted to the gun position which allows easy painting of door sills (from the side), or fenders"upside down").
2. The threaded connection between cup and lid ensures great stability. Even when touching an obstacle, the cup will remain safely in place and firmly connected to both lid and spray gun.
3. Whenever this is required, the threaded connection also helps to quickly detach the lid – without spilling paint onto the workplace. The paint strainer can be replaced at any time – e.g. for storage.
4. By squeezing the cup, a low pressure is created inside the cup which causes an efficient material passage drain while the gun trigger is pulled. This helps to keep the workplace clean when the cup is detached from the gun.



SATA® Loyalty Program

coins & more



1. Download App & register
2. Scan QR code under the lid
3. Collect coins & Convert into rewards



The paint is mixed in the cup and ready for painting.



SATA® RPS 0.6 | UV

60 cups, lids
flat sieves 125 µ: Order No. 1010496
plug-in sieves 200 µ: Order No. 1010503

RPS® Dispenser System



**Everything in
its place!**



SATA® RPS wall dispenser

Standard kit for up to 2 cup sizes:
2 aluminum brackets for wall
mounting, 2 tubes for cups, 2 tube
for lids, and 2 tubes for sieves
Order No. 195784



SATA® RPS rotawall adapter kit

Compact wall-mounting version: Wall
bracket with rotating spindle to mount the
basic version* and the extension kit*
Order No. 196543



SATA® RPS extension kit

Extension kit for one additional cup size:
each 1 tube for cups, 1 tube for lids
and one tube for the sieves (the brackets of the
standard kit are suitable for mounting the
extension kit)
Order No. 195776

SATA® RPS rotafloor adapter kit

Workbench/floor version: Height-adjustable
stand with floor plate and rotating spindle
to mount the basic version* and the
extension kit*
Order No. 196550



*not included in kit

Filter Regulators and Breathing Protection - for Perfect Finishes and Health Protection

The **SATA air vision 5000 focus is on effective health protection** and lets you experience a whole new and comfortable way of breathing, due to a completely re-designed breathing air supply system. With its modern, ergonomic design, the hood can be adapted to fit almost any head shape, allowing the individual adjustment of its circumference, height and position.



w/ carbon reg. set
Order No. 214718

w/ air regulator set
Order No. 1005603



SATA® air vision™ 5000

For the ultimate safety and protection

Whatever environment you are working in: Whether you want cooled, heated or re-humidified breathing air or simply looking for absolute safety from particle contamination – with the new add-on modules complementing the SATA air vision 5000 breathing protection system, you can be sure your health and comfort are both efficiently catered to.

- Rigid bump cap for safer work conditions
- Large field of vision: approximately 116" at a maximum possible angle of 220°
- Replaceable visor foils allow unchanging clear view
- Soft-stream flow-optimized air distribution in the hood



*More breathing hood part numbers are in the back of the brochure

SATA air vision 5000 system design with SATA filter systems

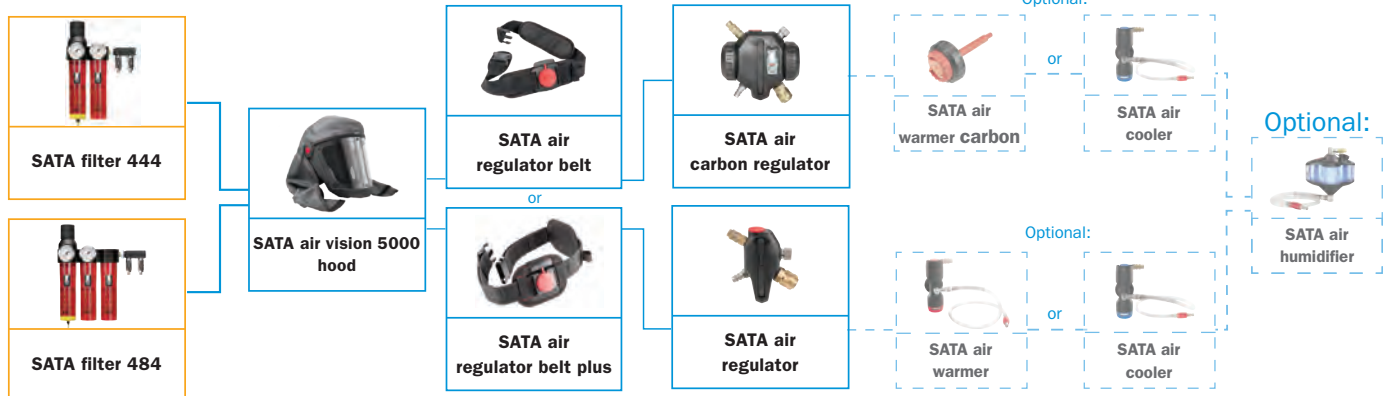

SATA air vision 2000 and SATA air star C options:



w/ charcoal filter
Order No. 36384

w/ Ind. belt valve
Order No. 60707



SATA® vision™ 2000

The complete health protection system

Supplied-air respirator hood with very high wearing comfort and optimum hygiene. The system perfectly complies with painters' requirements and protects their respiratory tracts, eyes, skin and hair (especially important for the application of waterborne paints).



w/ charcoal filter
Order No. 137547

w/ Ind. belt valve
Order No. 137745



SATA® air star C™

The supplied-air half mask

Skin-friendly mask made of TPE* with anatomically shaped sealing frame, solvent-resistant.

- Safe seat, free field of vision (protective goggles Part No. 97485 required, not included in delivery)
- No accumulation of heat and humidity inside the mask

SATA Filter System

200 and 400 Series

Every body shop requires compressed air for many different applications, such as for painting, operation of supplied-air respirator systems, paint pressure tanks, material pumps, blow guns or cleaning devices. According to the field of application, there are different requirements concerning air purification: In any case, SATA offers the appropriate solution.



SATA® Filter 400 series

The filter series for the spray booth

For the application of solvent-based paint material, a SATA filter 444 can be applied. For highest possible safety with the use of respirators and the application of waterborne paint material, we categorically recommend the SATA filter 484, as the activated charcoal filtering stage of this filter also eliminates hazardous oil vapours.

- Maximum protection for the painter
- Prevents expensive coating flaws
- Fine filter filtration to 0.01 micron
- Includes SATA filter timers to monitor the filter cartridge exchange intervals
- User-friendly and easy to maintain
- Quick and easy installation
- Economical and efficient
- Extremely high air flow 130 cfm at 90 psi
- Robust, durable filter canisters
- Suitability of the triple-stage filter (SATA filter 484) for applying waterborne paints and for breathing air
- Indicator – especially high contaminant contents in the compressed air may require shorter exchange intervals as indicated



SATA® Filter 444™

Dual-stage filter (without activated charcoal) – suitable for the application of solvent-based paints.
Order No. 92296



SATA® Filter 484™

Triple-stage filter (with activated charcoal) – to apply VOC-compliant paints, such as waterborne or high-solid paints.
Order No. 92320

Dan-Am point of use regulator

with two or four drop manifold, mounting bracket
Max inlet pressure: 216 psi
Max. cfm: 140

Two drop manifold
Order No. 675652

Four drop manifold
Order No. 675654



SATA® Filter 200 series

Along with the 400, the 200 filter series is the most versatile modular filter system currently on the market but at an unbeatable price.

- Air flow 72 cfm at 90 psi
- Fine filter filtration to 0.01 micron
- Maximum protection for the painter



SATA® Filter 244™

Double-stage sinter filter/fine filter with pressure regulator and outlet module Use to connect regulated air to air tools and breathing air
Order No. 44404 with 2 drop manifold
Order No. 44404-4 with 4 drop manifold



SATA® Filter 282™

Triple Stage (in-line) An economical three-stage filter unit. Stages include a 5 micron filter with automatic condensation discharger, a 0.01 micron fine filter and an activated charcoal filter for breathing air or spraying waterborne. Used with the SATA supplied air respirator industrial belt valve or ensuring removal of oil residue when spraying water borne paint.
Order No. 189290

Material Supply Systems for an Optimized Painting Process

For the application of larger amounts of paint, the SATA and Dan-Am material supply systems in combination with pressure fed SATA spray guns are the perfect equipment. The universally applicable systems feature easy handling, sturdy construction, long lifetime and little maintenance.

Advantages of SATA and Dan-Am material feed systems

- **High working speed** and surface coverage in combination with HVLP or RP spray guns that feature fine atomization
- **Enhanced profit** due to time saving efficiency
- **User friendly** from any height or upside down position
- **Perfect surface** finishes
- **Eliminates** frequent cup refilling
- **Effortless cleaning**
- Ideal for hard to reach areas due to **compact gun design**
- The **same material feed to two painters** is possible



Dan-Am 2.0L pressure pot - Aluminum

Dan-Am 2 liter aluminum pressure pot, complete with deck, regulator and tank Order No. 670200

Dan-Am 2.0L pressure pot - Stainless

Dan-Am 2 liter stainless steel pressure pot, complete with deck, regulator and tank Order No. 670400



Dan-Am Paint Pressure Tanks

Dan-Am Company offers a quality line of pressure tanks from 10 to 40 liter. These cost-effective tanks are supplied complete with a quality regulator, over-pressure valve, back-check valve and fluid shut-off valve. Dan-Am models include 10 liter pressure tanks with single or double pressure regulator either plain, with manual stirrer or with pneumatic stirrer. Other 20 and 40 liter variations are also offered with single or double pressure regulator. Tanks are mounted on wheels for ease of handling and mobility.

- Easy to handle with minimum maintenance and heavy-duty construction ensure long service and great user acceptance.
- Also available Disposable liners for 10 & 20 liter sizes.

*Pressure tank part numbers are in the back of the brochure

Dan-Am 2710 & 2733

pressure pumps

Ideal for trade and industry: cabinet shops, furniture industry, paint & finish shops, machine construction

- Soft, controllable spray pattern
- The finest atomization generates first class finishes
- 2 pressure ratio choices medium or high
- Perfect finishing system for high quality, even finishes
- Dual filter system prevents downtime
- Heavy duty housing and new seal system
- Quick simple maintenance



SATA® Vario top spray™

the double diaphragm pump

Efficient pump to apply large amounts of paint.

- The alternative to a paint pressure tank
- Aluminum and stainless steel versions
- Sturdy, low-wear and low maintenance
- Easy refill
- Several versions for mobile and stationary use are available
- Allows to work with open original containers – no refill or ventilation required as would be necessary with pressure tanks
- High performance spray gun SATAjet 3000 K not contained in the scope of delivery



Cleaning systems for spray guns

Spray gun cleaning is an important yet unpopular task amongst painters. SATA cleaning devices reliably help achieve correct gun cleaning **which is of vital importance not only in order to maintain proper function of the spray gun, but also to increase the process security in the body shop.**

SATA® clean RCS™

the turbo cleaner

For body shops with high output and many color changes.

- Rapid and safe color change when using disposable cups, such as SATA RPS
- Thorough cleaning of the material passages
- Eliminates the need for trips in and out of the booth, as it can be mounted inside the spray booth
- Increases body shop productivity

Order No. 146944



SATA® clean RCS™ compact

- To connect large cleaning agent containers
- Recommended for wall-mounting inside the mixing room, as there is no need for spray air supply
- Optional: Hose for extracting solvent fumes

Order No. 192518



SATA® clean RCS™ micro

The compact version is also available as space-saving option with a one-chamber-system.

- To connect large cleaning agent containers
- Recommended for wall-mounting inside the mixing room, as there is no need for spray air supply
- Space-saving one-chamber system
- Optional: Hose for extracting solvent fumes

Order No. 202564

Perfect Paint Applications

PART #	DESCRIPTION	
SATAjet X 5500		
STANDARD X 5500 HVLP I-nozzle		
1061895	SATAjet X 5500 HVLP Std, 1.0	HVLP I-Nozzle Sets
1061902	SATAjet X 5500 HVLP Std, 1.2	1063619
1061887	SATAjet X 5500 HVLP Std, 1.3	1063627
1061910	SATAjet X 5500 HVLP Std, 1.4	1063635
1061928	SATAjet X 5500 HVLP Std, 1.5	1063651
		1063669

STANDARD X 5500 HVLP O-nozzle		
1061936	SATAjet X 5500 HVLP Std, 1.0	HVLP O-Nozzle Sets
1061944	SATAjet X 5500 HVLP Std, 1.2	1063677
1061952	SATAjet X 5500 HVLP Std, 1.3	1063685
1061960	SATAjet X 5500 HVLP Std, 1.4	1063643
1061978	SATAjet X 5500 HVLP Std, 1.5	1063693
		1063700

DIGITAL X 5500 HVLP I-nozzle		
1062009	SATAjet X 5500 HVLP Digital, 1.1	
1061986	SATAjet X 5500 HVLP Digital, 1.2	
1062017	SATAjet X 5500 HVLP Digital, 1.3	
1062041	SATAjet X 5500 HVLP Digital, 1.4	
1062059	SATAjet X 5500 HVLP Digital, 1.5	

DIGITAL X 5500 HVLP O-nozzle		
1062083	SATAjet X 5500 HVLP Digital, 1.1	
1062091	SATAjet X 5500 HVLP Digital, 1.2	
1062132	SATAjet X 5500 HVLP Digital, 1.3	
1062140	SATAjet X 5500 HVLP Digital, 1.4	
1062174	SATAjet X 5500 HVLP Digital, 1.5	

STANDARD X 5500 RP I-nozzle		
1061548	SATAjet X 5500 RP Std, 1.0	RP I-Nozzle Sets
1061556	SATAjet X 5500 RP Std, 1.2	1063536
1061564	SATAjet X 5500 RP Std, 1.3	1063544
1061572	SATAjet X 5500 RP Std, 1.4	1063552
		1063560

STANDARD X 5500 RP O-nozzle		
1061580	SATAjet X 5500 RP Std, 1.0	RP O-Nozzle Sets
1061598	SATAjet X 5500 RP Std, 1.2	1063578
1061605	SATAjet X 5500 RP Std, 1.3	1063586
1061613	SATAjet X 5500 RP Std, 1.4	1063594
		1063601

DIGITAL X 5500 RP I-nozzle		
1063536	SATAjet X 5500 RP Digital, 1.1	
1063544	SATAjet X 5500 RP Digital, 1.2	
1063552	SATAjet X 5500 RP Digital, 1.3	
1063560	SATAjet X 5500 RP Digital, 1.4	

DIGITAL X 5500 RP O-nozzle		
1063578	SATAjet X 5500 RP Digital, 1.1	
1063586	SATAjet X 5500 RP Digital, 1.2	
1063594	SATAjet X 5500 RP Digital, 1.3	
1063601	SATAjet X 5500 RP Digital, 1.4	

SATAjet 5000 B		
STANDARD 5000 B HVLP		
210732	SATAjet 5000 B HVLP Std, 1.0	HVLP Nozzle Sets
210740	SATAjet 5000 B HVLP Std, 1.2	210955
210757	SATAjet 5000 B HVLP Std, WSB	210963
210765	SATAjet 5000 B HVLP Std, 1.3	210971
210799	SATAjet 5000 B HVLP Std, 1.4	210989
210823	SATAjet 5000 B HVLP Std, 1.5	211011
210831	SATAjet 5000 B HVLP Std, 1.7	211045
210849	SATAjet 5000 B HVLP Std, 1.9	211052
210856	SATAjet 5000 B HVLP Std, 2.2	211060
		211078

DIGITAL 5000 B HVLP		
211094	SATAjet 5000 B HVLP Digital, 1.0	
211110	SATAjet 5000 B HVLP Digital, 1.2	
211128	SATAjet 5000 B HVLP Digital, WSB	
211136	SATAjet 5000 B HVLP Digital, 1.3	
211151	SATAjet 5000 B HVLP Digital, 1.4	
211193	SATAjet 5000 B HVLP Digital, 1.5	
211201	SATAjet 5000 B HVLP Digital, 1.7	
211219	SATAjet 5000 B HVLP Digital, 1.9	

PART #	DESCRIPTION	
DIGITAL 5000 B RP		
210138	SATAjet 5000 B RP Digital, 1.0	RP Nozzle Sets
210146	SATAjet 5000 B RP Digital, 1.1	210245
210153	SATAjet 5000 B RP Digital, 1.2	210252
210161	SATAjet 5000 B RP Digital, 1.2W	210260
210179	SATAjet 5000 B RP Digital, 1.3	210278
210187	SATAjet 5000 B RP Digital, 1.4	210286
210195	SATAjet 5000 B RP Digital, 1.6	210294
210203	SATAjet 5000 B RP Digital, 1.8	210302
210211	SATAjet 5000 B RP Digital, 2.0	210310
		210328
		210336 2.5 nozzle

STANDARD 5000 B RP		
215640	SATAjet 5000 B RP Std, 1.1	
209858	SATAjet 5000 B RP Std, 1.2	
209866	SATAjet 5000 B RP Std, 1.2W	
209874	SATAjet 5000 B RP Std, 1.3	
209882	SATAjet 5000 B RP Std, 1.4	
209890	SATAjet 5000 B RP Std, 1.6	
209908	SATAjet 5000 B RP Std, 1.8	
209916	SATAjet 5000 B RP Std, 2.0	

SATAjet 5000 B PHASER		
SATAjet 5000 B HVLP PHASER		
1006924	SATAjet 5000 B PHASER HVLP, wsb	HVLP Nozzle Sets
1006817	SATAjet 5000 B PHASER HVLP, 1.3	1006875
1006825	SATAjet 5000 B PHASER HVLP, 1.4	1006883
1006833	SATAjet 5000 B PHASER HVLP, 1.5	1006891
		1006908
SATAjet 5000 B RP PHASER Standard		
1006776	SATAjet 5000 B PHASER RP, 1.2	RP Nozzle Sets
1006784	SATAjet 5000 B PHASER RP, 1.2W	1006841
1006792	SATAjet 5000 B PHASER RP, 1.3	1006859
		1006867

SATAjet 4000 B		
DIGITAL 4000 B HVLP		
176909	SATAjet 4000 B HVLP Digital, 1.0	
166249	SATAjet 4000 B HVLP Digital, 1.2	
170357	SATAjet 4000 B HVLP Digital, WSB	
170365	SATAjet 4000 B HVLP Digital, 1.3	
170373	SATAjet 4000 B HVLP Digital, 1.3 C	
170381	SATAjet 4000 B HVLP Digital, 1.3 LV	
170399	SATAjet 4000 B HVLP Digital, 1.4	
170407	SATAjet 4000 B HVLP Digital, 1.4 HC	
204354	SATAjet 4000 B HVLP Digital, HC+	
170704	SATAjet 4000 B HVLP Digital, 1.5	
176925	SATAjet 4000 B HVLP Digital, 1.7	
176933	SATAjet 4000 B HVLP Digital, 1.9	
176966	SATAjet 4000 B HVLP Digital, 2.2	

STANDARD 4000 B HVLP		
176891	SATAjet 4000 B HVLP Std, 1.0	HVLP Nozzle Sets
170159	SATAjet 4000 B HVLP Std, 1.2	166926
170167	SATAjet 4000 B HVLP Std, WSB	166934
170175	SATAjet 4000 B HVLP Std, 1.3	166983
170183	SATAjet 4000 B HVLP Std, 1.3 C	166942
170191	SATAjet 4000 B HVLP Std, 1.3 LV	166959
170209	SATAjet 4000 B HVLP Std, 1.4	168641
170217	SATAjet 4000 B HVLP Std, 1.4 HC	166967
204230	SATAjet 4000 B HVLP Std, HC+	171512
170696	SATAjet 4000 B HVLP Std, 1.5	200253
176917	SATAjet 4000 B HVLP Std, 1.7	166975
176941	SATAjet 4000 B HVLP Std, 1.9	168658
176958	SATAjet 4000 B HVLP Std, 2.2	168666
		168674

DIGITAL 4000 B RP		
176982	SATAjet 4000 B RP Digital, 1.0	RP Nozzle Sets
171553	SATAjet 4000 B RP Digital, 1.1	166991
170019	SATAjet 4000 B RP Digital, 1.2	167007
170027	SATAjet 4000 B RP Digital, 1.2W	167015
170035	SATAjet 4000 B RP Digital, 1.3	167023
170050	SATAjet 4000 B RP Digital, 1.4	167049
177006	SATAjet 4000 B RP Digital, 1.6	167056
177022	SATAjet 4000 B RP Digital, 1.8	167072
177048	SATAjet 4000 B RP Digital, 2.0	167080
177063	SATAjet 4000 B RP Digital, 2.5	168625
		168633

PART #	DESCRIPTION
STANDARD 4000 B RP	
176974	SATAjet 4000 B RP Std, 1.0
171520	SATAjet 4000 B RP Std, 1.1
169979	SATAjet 4000 B RP Std, 1.2
169987	SATAjet 4000 B RP Std, 1.2W
169995	SATAjet 4000 B RP Std, 1.3
170001	SATAjet 4000 B RP Std, 1.4
176990	SATAjet 4000 B RP Std, 1.6
177014	SATAjet 4000 B RP Std, 1.8
177030	SATAjet 4000 B RP Std, 2.0
177055	SATAjet 4000 B RP Std, 2.5

SATAminijet 4400 B

SATAminijet 4400 B HVLP		HVLP Nozzle Sets	
204164	Minijet 4400 B HVLP, 0.3, (2x) 0.3l RPS	201194	
204172	Minijet 4400 B HVLP, 0.5, (2x) 0.3l RPS	201202	
204180	Minijet 4400 B HVLP, 0.8, (2x) 0.3l RPS	201210	
204198	Minijet 4400 B HVLP, 1.0, (2x) 0.3l RPS	201228	
204206	Minijet 4400 B HVLP, 1.1, (2x) 0.3l RPS	201236	
198168	Minijet 4400 B HVLP, 0.8SR, (2x) 0.3l RPS	201244	
198176	Minijet 4400 B HVLP, 1.0SR, (2x) 0.3l RPS	201251	
198184	Minijet 4400 B HVLP, 1.2SR, (2x) 0.3l RPS	201269	
198192	Minijet 4400 B HVLP, 1.4SR, (2x) 0.3l RPS	201277	
198382	Minijet 4400 B Design Set, (specify nozzle size)		

SATAminijet 4400 B RP

SATAminijet 4400 B RP		RP Nozzle Sets	
202382	Minijet 4400 B RP, 0.5, (2x) 0.3l RPS	202408	
198374	Minijet 4400 B RP, 1.4, (2x) 0.3l RPS	201319	
204156	Minijet 4400 B RP, 1.6, (2x) 0.3l RPS	201327	
202390	Minijet 4400 B RP, 0.8SR, (2x) 0.3l RPS	201285	
198358	Minijet 4400 B RP, 1.0SR, (2x) 0.3l RPS	201293	
198366	Minijet 4400 B RP, 1.2SR, (2x) 0.3l RPS	201301	
198366	Minijet 4400 B RP, 1.3SR, (2x) 0.3l RPS	1065037	

SATAminijet 3000 B HVLP mini art

227967 SATAminijet 3000 B HVLP mini art, 1.2 SR

SATAjet 3000 K

SATAjet 3000 K HVLP w/adam2 (digital)

93286	SATAjet 3000 K HVLP, 0.8, w/adam2
92718	SATAjet 3000 K HVLP, 1.0, w/adam2
93294	SATAjet 3000 K HVLP, 1.2, w/adam2
96149	SATAjet 3000 K HVLP, 1.6, w/adam2
96156	SATAjet 3000 K HVLP, 2.0, w/adam2
93286ST	SATAjet 3000 K HVLP, 0.8 STN*, w/adam2
92718ST	SATAjet 3000 K HVLP, 1.0 STN*, w/adam2
93294ST	SATAjet 3000 K HVLP, 1.2 STN*, w/adam2
96149ST	SATAjet 3000 K HVLP, 1.6 STN*, w/adam2
96156ST	SATAjet 3000 K HVLP, 2.0 STN*, w/adam2

SATAjet 3000 K RP w/adam2 (digital)

92692	SATAjet 3000 K RP, 0.8, w/adam2
93120	SATAjet 3000 K RP, 1.1 w/adam2
93138	SATAjet 3000 K RP, 1.3 w/adam2
93146	SATAjet 3000 K RP, 1.5 w/adam2
93161	SATAjet 3000 K RP, 1.7 w/adam2
93179	SATAjet 3000 K RP, 2.0 w/adam2
92692ST	SATAjet 3000 K RP, 0.8 STN*, w/adam2
137869	SATAjet 3000 K RP, 1.1 STN*, w/adam2
137877	SATAjet 3000 K RP, 1.3 STN*, w/adam2
93146ST	SATAjet 3000 K RP, 1.5 STN*, w/adam2
93161ST	SATAjet 3000 K RP, 1.7 STN*, w/adam2
93179ST	SATAjet 3000 K RP, 2.0 STN*, w/adam2

SATAjet 3000 K HVLP Standard

SATAjet 3000 K HVLP Standard	HVLP Nozzle Sets
93385	SATAjet 3000 K HVLP, 0.8
92924	SATAjet 3000 K HVLP, 1.0
93393	SATAjet 3000 K HVLP, 1.2
193656	SATAjet 3000 K HVLP, 1.4
96164	SATAjet 3000 K HVLP, 1.6
96172	SATAjet 3000 K HVLP, 2.0
93385ST	SATAjet 3000 K HVLP, 0.8 STN*
92924ST	SATAjet 3000 K HVLP, 1.0 STN*
93393ST	SATAjet 3000 K HVLP, 1.2 STN*
137851	SATAjet 3000 K HVLP, 1.6 STN*
96172ST	SATAjet 3000 K HVLP, 2.0 STN*

SATAjet 3000 K RP Standard

SATAjet 3000 K RP Standard	RP Nozzle Sets
92932	SATAjet 3000 K RP, 0.8 RP
93336	SATAjet 3000 K RP, 1.1 RP
93344	SATAjet 3000 K RP, 1.3 RP

PART #	DESCRIPTION	
93351	SATAjet 3000 K RP, 1.5 RP	92528
93369	SATAjet 3000 K RP, 1.7 RP	95422
93377	SATAjet 3000 K RP, 2.0 RP	95356
163022	SATAjet 3000 K RP, 0.8 STN*	
141994	SATAjet 3000 K RP, 1.1 STN*	
142265	SATAjet 3000 K RP, 1.3 STN*	
166421	SATAjet 3000 K RP, 1.5 STN*	
196535	SATAjet 3000 K RP, 1.7 STN*	
137844	SATAjet 3000 K RP, 2.0 STN*	

*STN = Special Treated Extended Life Nozzle

SATAjet 1500 B SoLV

SATAjet 1500 B SoLV HVLP Standard	HVLP Nozzle Sets
1010925	SATAjet 1500 B SoLV HVLP, 1.3
1010933	SATAjet 1500 B SoLV HVLP, 1.4

SATAjet 1500 B SoLV RP Standard	RP Nozzle Sets
1010892	SATAjet 1500 B SoLV RP, 1.3
1010917	SATAjet 1500 B SoLV RP, 1.4

SATAjet 1000 K

SATAjet 1000 K HVLP	HVLP Nozzle Sets
139196	SATAjet 1000 K HVLP, 0.8
139204	SATAjet 1000 K HVLP, 1.0
139212	SATAjet 1000 K HVLP, 1.2
-	
139220	SATAjet 1000 K HVLP, 1.6
139238	SATAjet 1000 K HVLP, 2.0
141960	SATAjet 1000 K HVLP, 0.8, STN*
141978	SATAjet 1000 K HVLP, 1.0, STN*
141986	SATAjet 1000 K HVLP, 1.2, STN*
142000	SATAjet 1000 K HVLP, 1.6, STN*
142018	SATAjet 1000 K HVLP, 2.0, STN*

SATAjet 1000 K RP

SATAjet 1000 K RP	RP Nozzle Sets
132092	SATAjet 1000 K RP, 0.8
132100	SATAjet 1000 K RP, 1.1
132118	SATAjet 1000 K RP, 1.3
132126	SATAjet 1000 K RP, 1.5
132134	SATAjet 1000 K RP, 1.7
132142	SATAjet 1000 K RP, 2.0
153486	SATAjet 1000 K RP, 2.5
153494	SATAjet 1000 K RP, 3.0
154336	SATAjet 1000 K RP, 4.0
-	
161232	SATAjet 1000 K RP, 1.6 D
141903	SATAjet 1000 K RP, 0.8, STN*
141911	SATAjet 1000 K RP, 1.1, STN*
141929	SATAjet 1000 K RP, 1.3, STN*
141937	SATAjet 1000 K RP, 1.5, STN*
141945	SATAjet 1000 K RP, 1.7, STN*
141952	SATAjet 1000 K RP, 2.0, STN*
-	

*STN = Special Treated Extended Life Nozzle

SATAminijet 1000 K

SATAminijet 1000 K HVLP	K HVLP Nozzle Sets
190280	SATAminijet 1000K HVLP, 0.3
190298	SATAminijet 1000K HVLP, 0.5
190306	SATAminijet 1000K HVLP, 0.8
190314	SATAminijet 1000K HVLP, 1.0
190322	SATAminijet 1000K HVLP, 1.2

SATAminijet 1000 K RP

SATAminijet 1000 K RP	K RP Nozzle Sets
187450	SATAminijet 1000K RP, 0.3
187468	SATAminijet 1000K RP, 0.5
187476	SATAminijet 1000K RP, 0.8
187484	SATAminijet 1000K RP, 1.0
187492	SATAminijet 1000K RP, 1.2
197152	SATAminijet 1000K RP, 1.4
187419	Paint pipe, cpl. G1/4 - G1/4
199018	Paint pipe, cpl. G1/4 - G3/8

SATAminijet 1000 H

SATAminijet 1000 H	H Nozzle Sets
191502	SATAminijet 1000 H HVLP, 1.4
Inquire	SATAminijet 1000 H RP, 1.4ST
187682	SATAminijet 1000 H RP, 1.4
188318	RPS adapter No. 17

PART #	DESCRIPTION
188482	RPS Siphon cup kit for 0.3l, set of 25
188516	RPS Siphon cup kit for 0.3l, set of 50
188490	RPS Siphon cup kit for 0.6l, set of 25
188524	RPS Siphon cup kit for 0.6l, set of 50
188508	RPS Siphon cup kit for 0.9l, set of 25
188532	RPS Siphon cup kit for 0.9l, set of 50

SATAjet 100 B F

SATAjet 100 B F HVLP HVLP Nozzle Sets

1012674	SATAjet 100 BF HVLP, 1.4, RPS	146381
1012682	SATAjet 100 BF HVLP, 1.7, RPS	145417
1012690	SATAjet 100 BF HVLP, 1.9, RPS	145425
1012707	SATAjet 100 BF HVLP, 2.1, RPS	145433

SATAjet 100 B F RP RP Nozzle Sets

203125	SATAjet 100 BF RP, 1.1 UV, RPS	182600
1012632	SATAjet 100 BF RP, 1.4, RPS	146977
1012640	SATAjet 100 BF RP, 1.6, RPS	145250
1012658	SATAjet 100 BF RP, 1.8, RPS	145268
1012666	SATAjet 100 BF RP, 2.0, RPS	145276

SATAjet 100 B P P Nozzle Set

1012715	SATAjet 100 B P, RPS	145284
---------	----------------------	--------

SATAjet 20 B (formerly SATA dekor 2000) Nozzle Sets

65078	SATAjet 20 B, 0.2, 65 ccm PVC	60459
189035	SATAjet 20 B, 0.2F, 65 ccm PVC	189043
65581	SATAjet 20 B, 0.35, 65 ccm PVC	60640
		202515 0.35 surface treatment
65649	SATAjet 20 B, 0.5, 65 ccm PVC	61200
66316	SATAjet 20 B, 0.8, 65 ccm PVC	61341
69229	SATAjet 20 B, 1.0, 65 ccm PVC	61523
86181	SATAjet 20 B, 0.2, 65ccm PVC, 3 glass jars	
86199	SATAjet 20 B, 0.35, 65ccm PVC, 3 glass jars	
86207	SATAjet 20 B, 0.5, 65ccm PVC, 3 glass jars	
86215	SATAjet 20 B, 0.8, 65ccm PVC, 3 glass jars	
86223	SATAjet 20 B, 1.0, 65ccm PVC, 3 glass jars	
90381	SATAjet 20 B Design Set, (specify nozzle size)	

SATAgraph 4

S004H	SATAgraph 4, siphon feed
S004B	SATAgraph 4, gravity feed
S004S	SATAgraph 4, side feed
S005	SATAgraph Replacement Needle 0.4
S004HBS	3 gun kit w/case

kit supplied with:

1	S004B	SATAgraph 4B gravity-feed airbrush
1	S004H	SATAgraph 4H siphon-feed airbrush
1	S004S	SATAgraph 4S side-feed airbrush
1	S032	33mm (3/4oz) glass jar and siphon jar adapter
1	S039	metal side feed jar adapter and 1 oz glass jar
1	S051	PVC color cup lid for Gravity and Side-feed models
1	S0049	PVC lid for metal color cup siphon feed
1	S045 8	foot quick disconnect braided air hose
3	S046	Quick disconnect fitting/plug
1		Instruction manual

SATAgraph 1

134544	SATAgraph 1 2.5ml gravity cup airbrush, 0.25	134619
136069	SATAgraph 1 2.5ml gravity cup airbrush, 0.45	134635
139568	SATAgraph 1 5.0ml siphon cup airbrush, 0.25	
141408	SATAgraph 1 5.0ml siphon cup airbrush, 0.45	

SATAgraph 3

136077	SATAgraph 3 2.5ml gravity cup airbrush, 0.15	134643
134569	SATAgraph 3 2.5ml gravity cup airbrush, 0.25	134650
136085	SATAgraph 3 2.5ml gravity cup airbrush, 0.45	134668
134585	SATAgraph 3 5.0ml siphon cup airbrush, 0.25	
136093	SATAgraph 3 5.0ml siphon cup airbrush, 0.45	
136101	SATAgraph 3 5.0ml siphon cup airbrush, 0.65	134676

Pressure Pot, 2 Liter, Stainless Steel or Aluminum

670200	2 liter Aluminum Pressure Pot (Dan-Am) w/regulator and pressure gauge
670400	2 liter Stainless Steel Pressure Pot (Dan-Am) w/regulator and pressure gauge

Compressor

677600	Dan-Am Mini-Muscle Air Brush Compressor
--------	---

SATA Multi-tool

228999	SATA Multi-tool, extraction, spanners, bit holder, battery comp. opener, disassemble fluid tips, knife, pliers, implement to remove air micrometer screw
--------	--

PART #	DESCRIPTION
10-40 L Tanks	
671100	10 Liter Pot, W/O Agitator, S.P.R.
681100	10 Liter Pot, W/O Agitator, D.P.R.
672100	20 Liter Pot, W/O Agitator, S.P.R.
671200	10 Liter Pot, W/Manual Agitator, S.P.R.
681200	10 Liter Pot, W/Manual Agitator, D.P.R.

671300	10 Liter Pot, W/Pneumatic Agitator, S.P.R.
681300	10 Liter Pot, W/Pneumatic Agitator, D.P.R.
682100	20 Liter Pot, W/DbI regulator, w/o stirrer
672200	20 Liter Pot, W/Manual Agitator, S.P.R.
682200	20 Liter Pot, W/Manual Agitator, D.P.R.
672300	20 Liter Pot, W/Pneumatic Agitator, S.P.R.
682300	20 Liter Pot, W/Pneumatic Agitator, D.P.R.
674300	40 Liter Pot, W/Pneumatic Agitator, S.P.R.
684300	40 Liter Pot, W/Pneumatic Agitator, D.P.R.

S.P.R. = Single Pressure Regulator D.P.R. = Double Pressure Regulator

Tank Liners

671012	10 Liter Pressure Tank Liner, 12 Pk
671060	10 Liter Pressure Tank Liner, 60 Pk

Vario Top

72678	Vario Top Pump, S/S, Wall mounted, w/o run or hoses
72694	Vario Top Pump, S/S, on trolley, w/o gun or hoses
81406	Vario Top Pump, S/S, Stand, one gun connection
61507	Vario Top Pump, Std, Wall mounted, w/o gun and hoses
81661	Vario Top Pump, Std, Stand, w/o gun and hoses
61515	Vario Top Pump, Std, on trolley, w/o gun and hoses

Filters

SATA Filter 200 Series

43687	222 Single stage w/gauge/discharger, sinter filter
44434	234 Single stage in-line
141226	264 Single stage charcoal unit
43752	242 Line filter, w/o valve, w/mod.
44404	244 Dual filter w/press reg & mod, 2 drop
44404-4	244 Dual filter w/press reg & mod, 4 drop
141226	264 Add-on charcoal filter unit
189290	282 Triple Stage Line filter
141218	284 Triple Filter w/reg valve & module (2 drop)
141218-4	284 Triple Filter w/reg valve & module (4 drop)
142224	Manifold, 200 Series w/couplings
47290	Regulator, 200 Series
47290A	Point of use regulator w/two drop manifold, mounting bracket
47290B	Regulator mounting bracket only 200 series
675614	Low profile mounting bracket

SATA Filter 400 Series

92213	414 Single Stage Filter
92254	414L Single Stage Line Filter
92288	420 Line Pressure Regulator
92221	424 Single Stage Filter w/reg.
92262	424L Single Stage Line Filter w/reg
92239	434 Single Stage Fine Filter
92270	434L Single Stage Line Fine Filter
92296	444 Double Stage Fine Filter
92296-4	444 Double Stage, 4 drop
92833	444 Dual Stage Filter With Stand
92247	464 Activated Charcoal Filter
141473	464 Add-on Charcoal Filter
92247L	464L In-line Charcoal Filter
92320	484 Triple W/Charcoal w/o Module
92320-4	484 Triple w/charcoal 4 drop
92320L	482 Triple Stage In-line
53579	Standard wall bracket, 400 series

Respirators

SATA air vision 5000

1005596	vision 5000 hood unit only
1005603	vision 5000 hood, belt, SATA air regulator
214718	vision 5000 hood, belt, SATA air carbon regulator
1000223	SATA air regulator belt
1000182	SATA air carbon regulator
1000207	SATA air regulator
1000314	SATA air humidifier, accessory
1006990	SATA air cooler, accessory
1007021	SATA air warmer, accessory
1000158	SATA air warmer carbon for air carbon regulator
218206	Activated charcoal filter replacement for air carbon regulator

PART # DESCRIPTION

SATA air vision 2000

51854	vision 2000 hood unit only
36384	vision 2000 with charcoal filter belt unit
37200	SATA activated charcoal belt unit only
60707	vision 2000 with industrial belt valve unit
61002	SATA industrial belt unit only
60541	Gray head/chest cape only

HKU Barrel Pump Unit

14555	HKU 60L Pump, w/gun/hoses/wands
34389	HKU 200L Pump, w/gun/hoses/wands

Dan-Am High Pressure Pumps

call	2710 Dan-Am medium pressure pump
call	2733 Dan-Am high pressure pump

SATA trueSun

1012129	SATA trueSun incl. battery and charger
1013094	SATA trueSun storage case w/foam inlay
1013151	Foam inlay only for SATA trueSun storage case
1010082	Battery
1006445	Battery charger
1012096	Protective lens holder
1012137	Lens only

SATA Dry-Jet 2

217489	Dry-Jet 2 Blow Gun
223008	Stand, W/2 Dry-Jet 2 Guns
223503	Stand, W/4 Dry-Jet 2 Guns
86140	Width Ext. Dry-Jet Stand W/3rd Gun
222232	Dry-Jet 2 filter holder
222125	SATA spare flat sieve 125µ 10 pc.
720640	Dan-Am Econo-Jet stand w/2 SATA Dry-Jet 2 Guns
720580	Econo-Jet stand only

Blow Guns

15156	Standard Nozzle	15214	Multi-nozzle
15180	Noiseless	133306	Pocket size

SATA RPS Dispenser

195784	Basic wall mount kit, 2 cups, 2 lids, 2 sieves
195776	Extension kit, additional, 1 cup, 1 lid tubes
196543	Rotowall adapter kit for mtg. basic and ext. kits
196550	Rotofloor adapter kit for mtg. basic and ext. kits

SATA adam 2

160697	SATA adam 2, display only, fits on all adam 2 & adam 2 U docks
1031658	SATA adam 2 black, display only, fits on all adam 2 & 2 U docks
160739	Battery set
160788	SATA adam 2, dock only
160796	SATA adam 2, dock, 2 pack
160853	SATA adam 2, dock, psi display, full sz guns except 5000 series
160861	SATA adam 2, mini dock only
160887	SATA adam 2, mini, psi complete
162164	Display unit clip only, 5 pk
162172	O-Ring, 2 pack
211557	SATA adam 2, complete, SATAjet 5000 only
211565	SATA adam 2, dock only, SATAjet 5000 only
211573	SATA adam 2, dock only (X2) SATAjet 5000 only
1031715	SATA adam 2 black, complete, SATAjet 5000 only

SATA adam 2 U

195222	SATA adam 2 U, complete
195230	SATA adam 2 U, air micrometer, w/dock
195925	SATA adam 2 U, dock only

Quality Dual hoses for pressure fed systems

3/8" air, 1/4" material, *Other sizes available*

675206	6'	675225	25'
675215	15'	675250	50'

Hose Assembly, 3/8 ID, New Air Vision 5000 hose w/coupler & nipple. NIOSH approved

676010	Premium Breathing Hose 10'
676015	Premium Breathing Hose 15'
676020	Premium Breathing Hose 20'
676025	Premium Breathing Hose, 25'
676035	Premium Breathing Hose, 35'
676050	Premium Breathing Hose, 50'
676075	Premium Breathing Hose, 75'
676100	Premium Breathing Hose, 100'

PART # DESCRIPTION

Hoses, 3/8 ID, Vision 2000, 1/4 male fitting

3366	Premium Breathing Hose, 25'
4635	Premium Breathing Hose, 35'
6633	Premium Breathing Hose, 50'
134791	Braided Hose, 2.5 Meter, SATAgraph

Hoses, w/1/4" BSP, male thread

678010	Premium Breathing Hose, 10'
678015	Premium Breathing Hose, 15'
678020	Premium Breathing Hose, 20'
678025	Premium Breathing Hose, 25'
678035	Premium Breathing Hose, 35'
678050	Premium Breathing Hose, 50'
678075	Premium Breathing Hose, 75'
678100	Premium Breathing Hose, 100'

Paint Pipe

92031	Paint pipe, pressure fed guns, 3/8 SS
-------	---------------------------------------

Repair Kits

211532	SATAjet 5000 B HVLP, RP repair kit
166058	SATAjet 4000 B HVLP, RP repair kit,
92767	SATAjet 3000 K, HVLP & RP repair kit
130542	SATAjet 1000 K, HVLP & RP repair kit
130542	SATAjet 100 B F repair kit
198614	SATAminijet 4400 B repair kit
126284	SATAminijet 3000 B/K, repair kit
69377	SATAjet 20 B, repair kit
134841	SATAgraph 1, repair kit
32276	SATAgraph 2, repair kit
134858	SATAgraph 3, repair kit
94979	SATA Filter 400 Series repair kit



Dan-Am Kneeler

Dan-Am Kneeler is an excellent tool to cushion your knees on rough or hard surfaces.
Order # **KNE0002**



Dan-Am Stadium Seat

- Comfort and softness
- Waterproof and floats
- Reverse side cup holders
- Light weight, just over 1 lb
- Easy cleaning, solvent resistant
- Built in handle, easy to carry

Part No. **SSBR1 (ea.)**
SSBR2 (2 pk)



Dan-Am Hosemate

Designed to guide hoses effortlessly around wheels. This means the painter can maneuver quickly and freely while applying costly time-sensitive coatings. It also reduces wear and tear on hoses. Order No. 10102

Accessories & Apparel



Large Double Door Cabinet

SATA cabinet by Dan-Am Co. Large double door lockable gun cabinet Material: 20 gauge steel
Storage: 2 shelves, locker, hangers for 7 gravity fed spray guns
Measurements: 46 in w x 35 in h x 12 in d / 116 cm x 89 cm x 30.5 cm

Must be shipped by truck, please call for a freight quote.
FREIGHT CHARGES NOT INCLUDED

Order No. 95

SATA Gun Holders



SATA universal wall mount gravity gun holder.

This type may be screwed to the wall at various locations for convenient storage.

Order No. 9886

SATA Wall or Bench Mount Heavy Duty Gravity Gun Holder. Red solvent resistant coating. Also works great for the SATA Mini-Jet. Gravity cup is held in the vertical position for easy refilling. Complete with mounting screws.

Order No. 40188



SATA Black Gun stand with logo, includes a nut to attach and display a SATA gun. *SATA gun NOT included*
Order No. 1750



Small Single Door Cabinet

SATA cabinet by Dan-Am Co. Small single lockable gun cabinet Material: 20 gauge steel
Storage: 1 shelf, and hangers for 7 gravity fed spray guns

Measurements: 25 in w x 35 in h x 12 in d / 63 cm x 89 cm x 30.5 cm

Order No. 96

Extra Gun Shelf Holders

Dan-Am Co. Extra gun shelf holders are available that hold 3 guns or 4 guns. The shelves must be staggered in any order 4 gun or 3 gun so the spray guns are not resting on each other. Fits both cabinets

Order No. 9898-3A Cabinet three (3) gun holder shelf

Order No. 9898-4 Cabinet four (4) gun holder shelf

Dan-Am Gun Holders



Dan-Am Gun holder for SATA-minijet 3000 B HVLP

Suitable for wall mounting, mounting in cabinet or mounting on a 9898 or 9890 gun holder

Order No. 9890-M



Dan-Am Wall mounted gun holder

9898-3 3 gun holder
9898-4 4 gun holder
9898-6 2x wall mounted 3 gun holder, holds 6 guns total



Dan-Am Bench Mounted Gravity Gun Holder

With Built-in Strainer Holder
Holds gravity gun perfectly straight for easy straining/refilling. Anodized black aluminum construction. Special plastic channel guide protects air cap horns. Screws to workbench.

Order No. 9890

Special portable version with heavy metal base for on-site work (shown)
Order No 9890-A

Metal base only Order No. 9890-B

Check out our
SATA GEAR website!

www.satausagear.com

Apparel & More



Dan-Am Paint Suits

The Dan-Am Pro-Series paint suit is expertly designed for fit and movement, with sewn in Carbon Fiber Thread to dissipate electro-static charges which cannot wash out. Made with the finest quality fabric and specially treated to keep it lint free. The suit has a covered heavy duty zipper, exterior utility Velcro pocket, adjustable sleeve and leg Velcro closures, wide leg, adjustable elastic waste band for fit and comfort, fully breathable back fabric, 2 utility back pockets, underarm zipper opening for ventilation when needed, lengthened side zipper, bi-swing shoulders for easier movements. Lighter weight protective fabric in the hood, machine washable.

Outperforms disposable coveralls and outlasts them at least ten to one.

SGS Tested, ATCC118-2007, Grade 8

(Download SGS test report from www.satausa.com)



Pro Series Dan-Am Paint Suit	
510050PS	X-Small
510052PS	Small
510054PS	Medium
510056PS	Large
510058PS	XLarge
510060PS	XXLarge (2XL)
510062PS	XXXLarge (3XL)

Please Note: Order the Pro-Series paint suit as you would your normal size, these run a little larger to fit over your clothing.

Dan-Am Paint Suits
 Dan-Am Company offers this high quality paint suit with SATA logo on the front and back. They are made of 100% breathable polyester that offers superior protection over clothing. These paint suits are treated to be anti-static, open at the wrist, ankle and face, available in white or gray. The Dan-Am paint suits are machine washable and available in sizes X-Small to 4XL.

White Dan-Am Paint Suit	
530050W	X-Small
530052W	Small
530054W	Medium
530056W	Large
530058W	XLarge (XL)
530060W	XLarge (2XI)
530062W	XXXLarge (3XI)
530064W	XXXXLarge (4XI)



Gray Dan-Am Paint Suits	
520052G	Small paint suit
520054G	Medium paint suit
520056G	Large paint suit
520058G	X-Large paint suit (XL)
520060G	XX-Large paint suit (2XL)
520062G	XXX-Large paint suit (3XL)
520064G	XXXX-Large paint suit (4XL)



***Please Note:** This chart is a guide for Dan-Am Paint Suit. Proper fit varies with under clothing and body shape. We recommend ordering one size larger after locating your size on the chart.

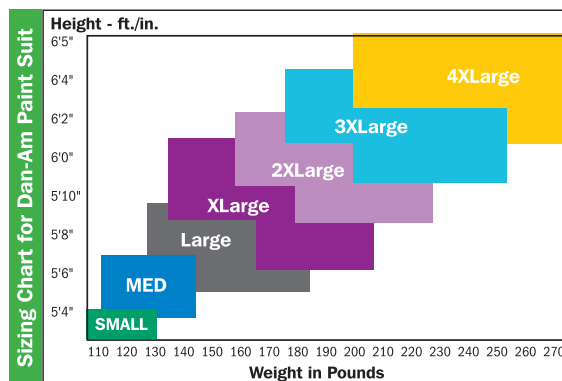

Everything for the Modern Body Shop and Workshop



PREMOFLEX Breathing Hose
Top quality breathing hose for breathing air and air tools. Available in lengths up to 100 feet. Part Numbers on page 25



Dan-Am Hosemate
Designed to guide hoses effortlessly around wheels. This means the painter can maneuver quickly and freely while applying costly time-sensitive coatings. It also reduces wear and tear on hoses. Order No. 10102

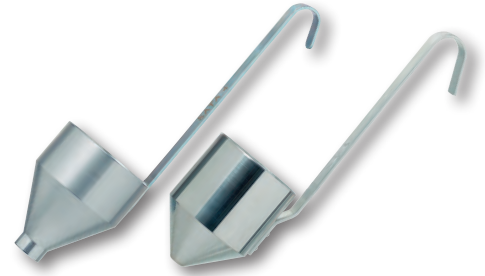

SATA Viscosity Cup
DIN 4 mm viscosity cup for consistent measuring of material viscosity
Order # 9845 Turned aluminum
Order # 9852 Extruded aluminum

Easy-Flex
The Most Flexible, Versatile and Efficient Stand Anywhere!

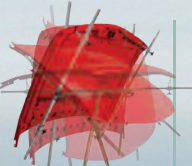

SATA HRS™
Pressurized cup gun for undercoating and wax injection. Supplied with three types of wands for different cavities. Order No. 9795



DanAm Air Vac
Removes foreign objects from wet paint/clearcoat. Saves work and costly re-do's Order No. DAA1001K



Airbrush Kit



Maintenance Kit

Cleaning Sets
Special needles and brushes for keeping your spray gun in optimum performance.
Airbrush Kit Order # 64036
Maintenance Kit Order # 64035

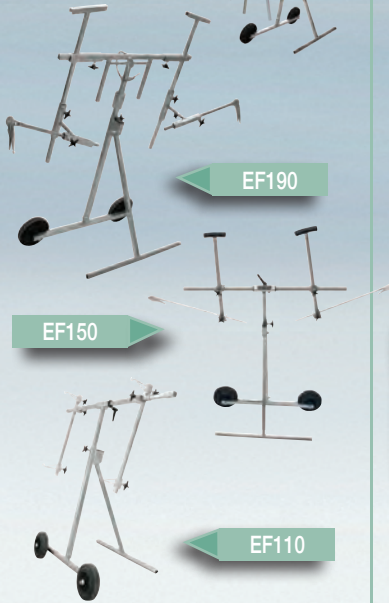

SATA® filter cover
(4 pieces) fits 400 filter series. A cover for both double-stage and triple-stage, protects filters from over spray, damages, dust
Order No. 215053



A Savings of \$191

SATA® filter replacement kit
Service kit for filter cartridges:
One year supply
Includes (2) 81810 + (4) 85373
Order No. 214270



Order No. X144

CO Monitors

For individual use, ICOM (X144) or for larger shops, Guardian (X767).



Order No.

X767-Plus



SATA sandblasting gun
Quick and easy removal of small corrosion spots.
Order No. 17335

Dan-Am Handy Stand
Multi-directional stand for sanding to painting. Adjusts to nearly 360° any direction.



Order No. 702100

Find out more information on the SATA app



DanAm®

The exclusive independent distributor of SATA product in the US and Puerto Rico

One SATA Drive
Spring Valley, MN 55975
Phone: 800-533-8016
Fax: 800-633-7282
e-mail: satajet@satausa.com
www.satausa.com

Your SATA dealer

Errors and technical alterations reserved - SATA, SATAjet and/or other SATA products referenced here-in are either registered trademarks or trademarks of SATA GmbH & Co. KG in the U.S. and/or other countries.

12_Complete Car Refinish
Printed in U.S.A.
18-0307