

Dan-Am Co.® Catalog 22

Rev. 2013

Spray Guns | Cup Systems | Breathing Protection | Filtration | Accessories



DanAmAir®

SATA
German Engineering

and other equipment offered by Dan-Am Co.

***Dan-Am Co. is the Exclusive Independent Distributor
of SATA Products in the US and Puerto Rico***

This catalog also contains non-SATA products that are offered by Dan-Am Co.
only in its capacity as an independent entity operating on its own.

Table of Contents



General Shipping Information.	1	SATAjet® Lab Test	64-65	Filtration	110-121
Application Recommendations for Spray Guns . . .	2-3	Nozzle Sets for Older spray gun models . . .	66-79	SATA® filter 414™/424™/434™/464™	112-113
Cutaway Model of SATAjet 4000 B	4	If your spray gun is not listed, please visit www.satausa.com for more spare parts.		SATA® filter 444™/474™/484™	114-115
Application Recommendations for Cup Systems . . .	5	SATAjet® 3000 B RP®/HVLP	68-69	SATA® filter 222™/242™/244™/284™	116-117
Application Recommendations for Breathing Protection	6	SATAjet® 2000 B RP®/HVLP	70-71	Accessories for SATA® filters	118-119
Application Recommendations for Filtration Technology	7	SATAjet® KLC RP®/HVLP; SATAjet® KLC P . . .	72-73	Filter head connection	120
Application Recommendations for Accessories . . .	8	SATAjet® B (SATAjet® GR)	74-75	SATA® filter 400 series cutaway	121
Dan-Am Paint Spray Equipment	9	SATAjet® B (SATAjet® GR)	76-77	Accessories	122-141
Warranty information	185	Accessories for SATA spray guns	78-81	SATA® clean RCS™	124
Spray Guns	12 - 78	SATA® adam™ 2	78-79	Cleaning and Maintenance of Spray Guns . . .	125
SATAjet® 4000 B RP®/HVLP	12-13	Air Micrometers	78	SATA® dry jet™ & SATA® dry jet™ accessories	126-129
SATAjet® 3000 K RP®/HVLP	14-15	Quick Coupling, Nipples, Gun Holders, Spray gun cleaning brushes, Viscosity cup, Dosenboy, Air cap protectors, SATA cert . . .	80-81	SATA blow guns	130
SATAjet® 3000 K spray mix	16-17	Spray gun cleaning and maintenance	82-83	Rust proofing Equipment	130-134
SATAjet® 1000 B RP®/HVLP	18-19	SATA Calculator, Helpful Tips, Metric Conversion Chart	84	SATA® HKU Pump	134-135
SATAjet® 1000 K RP®/HVLP	20-21	Cup Systems	85-95	SATA® vario top spray™	136-140
SATAjet® 1000 K Specialty	22-23	SATA® RPS™ Disposable Cup System	86-87	Quick Couplings	141
K D RP		Accessories for SATA® RPS™	88	Dan-Am Co.® Products.	143-182
K Slit Nozzle		Adapters for SATA® RPS™	89	Dan-Am Air	144-145
K RP KK HKU Undercoating		Gravity Flow & Siphon Cups	90-91	Carbon Monoxide Monitors	146-147
SATAjet® 1000 H RP®/HVLP	24-25	Glass Siphon and cup adapters	92	Dan-Am Cabinets and spray gun holders	148
Pressure fed material and air connection . . .	26-27	SATA® BVD™	93	Dan-Am Air Vac	149
Nozzle Extensions & Pressure fed accessories	28-29	SATA® Agitator cup	94	Easy Flex Panel Paint Stand	150-153
SATAjet® 100 BF RP®/HVLP		Breathing Systems	95-109	Dan-Am How-to DVDs and books	154
SATAjet® 100 B P	30-31	Breathing Protection w/Activated Charcoal Belt	96	Dan-Am Paint Suits	155
SATAjet® 90-2	32-33	Breathing Protection w/Industrial Belt Valve	97	SATAwear	156-157
SATAminijet® 3000 B HVLP	34-35	SATA® vision™ 2000 w/Activated Charcoal Belt	98-99	Dan-Am Pro Stencils/ Sticky Mickey masking paper	158-159
SATAminijet® 1000 K RP/HVLP	36-37	SATA® air star C™ w/Activated Charcoal Belt	100-101	Sales and Demo Support/cases	160
SATAminijet® 1000 H RP/HVLP	38-39	SATA® vision™ 2000 w/Industrial Belt Valve	102-103	Dan-Am Hoses	161
SATAjet® 20 B	40-41	SATA® air star C™ w/Industrial Belt Valve	104-105	Dan-Am Pressure Pots	162-163
SATAglyph™ 1/2/3	42-43	Accessories for SATA® vision™ 2000 Accessories for SATA® air star C™	106-107	Dan-Am 10-20 L Pressure Tank	164-167
SATAglyph™ 4	44-45	SATA® air star F™	108-109	Dan-Am Pressure Regulators	168-169
Spray gun cleaning	46			Dan-Am Piranha 338 SS 1:1 pump	170-171
Automatic and Robotic spray guns . . .	47-64			Dan-Am 7232 High Pressure Pump	172-175
SATAjet® 3000 ROB RP®/HVLP	48-49			Dan-Am 2710 Medium and 2733 High Pressure Pump	176-179
SATAjet® 3000 A RP®/HVLP	50-51			Dan-Am Air Assist Pump System Order Form . .	180
SATAminijet® 3000 A HVLP	52-53			Dan-Am 5 Gallon Agitator Lid	181
SATAminijet® 3000 A S HVLP	54-55			Dan-Am Brochures, Decals, Posters	182
SATAminijet® 3000 ROB HVLP	56-57			Viscosity Conversion chart	183
SATAjet® 1000 A RP®	58-59			Dan-Am Brochures, Posters, Decals	184
SATAjet® LPS 2000 RP®	60-61				
SATAjet® 3000 A spray mix	62-63				

Table of Contents







General Shipping Information.	1	SATAjet® Lab Test	64-65	Filtration	110-121
Application Recommendations for Spray Guns	2-3	Nozzle Sets for Older spray gun models	66-79	SATA® filter 414™/424™/434™/464™	112-113
Cutaway Model of SATAjet 4000 B	4	If your spray gun is not listed, please visit www.satausa.com for more spare parts.		SATA® filter 444™/474™/484™	114-115
Application Recommendations for Cup Systems	5	SATAjet® 3000 B RP®/HVLP	68-69	SATA® filter 222™/242™/244™/284™	116-117
Application Recommendations for Breathing Protection	6	SATAjet® 2000 B RP®/HVLP	70-71	Accessories for SATA® filters	118-119
Application Recommendations for Filtration Technology	7	SATAjet® KLC RP®/HVLP; SATAjet® KLC P	72-73	Filter head connection	120
Application Recommendations for Accessories	8	SATAjet® B (SATAjet® GR)	74-75	SATA® filter 400 series cutaway	121
Dan-Am Paint Spray Equipment	9	SATAjet® B (SATAjet® GR)	76-77	Accessories	122-141
Warranty information	185	Accessories for SATA spray guns	78-81	SATA® clean RCS™	124
Spray Guns	12 - 78	SATA® adam™ 2	78-79	Cleaning and Maintenance of Spray Guns	125
SATAjet® 4000 B RP®/HVLP	12-13	Air Micrometers	78	SATA® dry jet™ & SATA® dry jet™ accessories	126-129
SATAjet® 3000 K RP®/HVLP	14-15	Quick Coupling, Nipples, Gun Holders, Spray gun cleaning brushes, Viscosity cup, Dosenboy, Air cap protectors, SATA cert	80-81	SATA blow guns	130
SATAjet® 3000 K spray mix	16-17	Spray gun cleaning and maintenance	82-83	Rust proofing Equipment	130-134
SATAjet® 1000 B RP®/HVLP	18-19	SATA Calculator, Helpful Tips, Metric Conversion Chart	84	SATA® HKU Pump	134-135
SATAjet® 1000 K RP®/HVLP	20-21	Cup Systems	85-95	SATA® vario top spray™	136-140
SATAjet® 1000 K Specialty	22-23	SATA® RPS™ Disposable Cup System	86-87	Quick Couplings	141
K D RP		Accessories for SATA® RPS™	88	Dan-Am Co.® Products.	143-182
K Slit Nozzle		Adapters for SATA® RPS™	89	Dan-Am Air	144-145
K RP KK HKU Undercoating		Gravity Flow & Siphon Cups	90-91	Carbon Monoxide Monitors	146-147
SATAjet® 1000 H RP®/HVLP	24-25	Glass Siphon and cup adapters	92	Dan-Am Cabinets and spray gun holders	148
Pressure fed material and air connection	26-27	SATA® BVD™	93	Dan-Am Air Vac	149
Nozzle Extensions & Pressure fed accessories	28-29	SATA® Agitator cup	94	Easy Flex Panel Paint Stand	150-153
SATAjet® 100 BF RP®/HVLP		Breathing Systems	95-109	Dan-Am How-to DVDs and books	154
SATAjet® 100 B P	30-31	Breathing Protection w/Activated Charcoal Belt	96	Dan-Am Paint Suits	155
SATAjet® 90-2	32-33	Breathing Protection w/Industrial Belt Valve	97	SATAwear	156-157
SATAminijet® 3000 B HVLP	34-35	SATA® vision™ 2000 w/Activated Charcoal Belt	98-99	Dan-Am Pro Stencils/ Sticky Mickey masking paper	158-159
SATAminijet® 1000 K RP/HVLP	36-37	SATA® air star C™ w/Activated Charcoal Belt	100-101	Sales and Demo Support/cases	160
SATAminijet® 1000 H RP/HVLP	38-39	SATA® vision™ 2000 w/Industrial Belt Valve	102-103	Dan-Am Hoses	161
SATAjet® 20 B	40-41	SATA® air star C™ w/Industrial Belt Valve	104-105	Dan-Am Pressure Pots	162-163
SATAglyph™ 1/2/3	42-43	Accessories for SATA® vision™ 2000 Accessories for SATA® air star C™	106-107	Dan-Am 10-20 L Pressure Tank	164-167
SATAglyph™ 4	44-45	SATA® air star F™	108-109	Dan-Am Pressure Regulators	168-169
Spray gun cleaning	46			Dan-Am Piranha 338 SS 1:1 pump	170-171
Automatic and Robotic spray guns	47-64			Dan-Am 7232 High Pressure Pump	172-175
SATAjet® 3000 ROB RP®/HVLP	48-49			Dan-Am 2710 Medium and 2733 High Pressure Pump	176-179
SATAjet® 3000 A RP®/HVLP	50-51			Dan-Am Air Assist Pump System Order Form	180
SATAminijet® 3000 A HVLP	52-53			Dan-Am 5 Gallon Agitator Lid	181
SATAminijet® 3000 A S HVLP	54-55			Dan-Am Brochures, Decals, Posters	182
SATAminijet® 3000 ROB HVLP	56-57			Viscosity Conversion chart	183
SATAjet® 1000 A RP®	58-59			Dan-Am Brochures, Posters, Decals	184
SATAjet® LPS 2000 RP®	60-61				
SATAjet® 3000 A spray mix	62-63				

Application Recommendations for Spray Guns



1. High Performance Spray Guns





Spray gun type	Fields of applications	Operating Mode
1.1 SATAjet 4000 B HVLP/RP Page 12 13 	For top coat applications meeting highest requirements in terms of colour match precision, uniform distribution and gloss. Ideally suited for car refinishing, interior design, wood coating and the furniture industry.	<ul style="list-style-type: none"> Optionally available in HVLP low pressure or optimised high pressure RP technology Round/flat spray control Material flow control Air micrometer Gravity flow cup with QCC bayonet lock or RPS disposable cup Optional feature: integrated digital pressure gauge
1.2 SATAjet 3000 K HVLP/RP Page 14 15 	Same field of application as 1.1. Ideally suited for coating large areas, e.g. on commercial vehicles, or application of textured paints with air atomising technology.	<ul style="list-style-type: none"> To be used in combination with paint pressure tanks or low pressure pumps, i.e. SATA vario top spray double membrane pump Same functional features as 1.1
1.3 SATAjet 3000 K spray mix Page 16 17 	Ideally suited for coating large areas in the furniture and metalworking industry	<ul style="list-style-type: none"> To be used in combination with high pressure air assisted pumps (max. 250 bar), i.e. SATA shark or SATA dolphin Round/flat spray control Air micrometer

2. Universal Spray Guns for Industry

Spray gun type	Fields of applications	Operating Mode
2.1 SATAjet 1000 B HVLP/RP Page 18 19  SATAjet 1000 H RP Page 24 25 	For the application of a wide array of different materials, from primer materials and paint to glue and separating agents in craft and industry. A comprehensive range of accessories is available for this spray gun, including extensions, slit nozzles, and nozzle set-ups for glue application.	<ul style="list-style-type: none"> Optionally available in HVLP low pressure or optimised high pressure RP technology. Round/flat spray control Material flow control Air micrometer Gravity flow cup with QCC bayonet lock or suction cup
2.2 SATAjet 1000 K HVLP/RP Page 20 21 	Same field of application as 2.1., but for coating large areas.	<ul style="list-style-type: none"> To be used in combination with paint pressure tanks or low pressure pumps, i.e. SATA vario top spray Same functional features as 2.1
2.3 SATAjet 1000 K Specialty Guns K D, Slit Nozzle KK HKU Rustproof Page 22 23 	Specialty spray guns for the application of adhesives, textures and rustproofing material	<ul style="list-style-type: none"> To be used in combination with paint pressure tanks or low pressure pumps, i.e. SATA vario top spray Same functional features as 2.1
2.4 SATAminijet 1000 K HVLP/RP Page 36 37 	Same field of application as 2.1, but for coating large areas.	<ul style="list-style-type: none"> To be used in combination with paint pressure tanks or low pressure pumps, i.e. SATA vario top spray Same functional features as 2.1
2.5 SATAminijet 1000 H HVLP/RP Page 38 39 	Same field of application as 2.1, but for coating large areas.	<ul style="list-style-type: none"> To be used in combination with paint pressure tanks or low pressure pumps, i.e. SATA vario top spray Same functional features as 2.1

Application Recommendations for Spray Guns

3. Spray Guns for Primer and Filler Applications		
Spray gun type	Fields of applications	Operating Mode
3.1 SATAjet 100 B F HVLP/ RP Page 30 31 	Application of primer and filler materials in craft and industry	<ul style="list-style-type: none"> Optionally available in HVLP low pressure or optimised high pressure RP technology Round/flat spray control Material flow control Air micrometer Gravity flow cup with QCC bayonet lock
3.2 SATAjet 100 B P Page 30 31 	Application of polyester filler and sprayable putty	<ul style="list-style-type: none"> High pressure spray gun with shortened air cap horns, without air micrometer Same functional features as 3.1, without air micrometer
3.4 SATAjet 90-2 B HVLP Page 32 33 	Dedicated sealer gun with excellent atomization for the application of topcoat sealers.	

4. Universal Spray Guns for Industry		
4.1 SATAminijet 3000 B HVLP Page 34 35 	Spray gun for small paint jobs, e.g. spot repair and touch-ups in the automotive sector or custom design in craft and industry. Also perfectly suitable for the application of separating agents.	<ul style="list-style-type: none"> HVLP low pressure atomisation Round/flat spray control for left and right handed painters Reusable cup with mini QCC bayonet lock Material flow control Air micrometer
4.2 SATAjet 20 B Page 40 41 	Spray gun for custom design in craft and industry, calligraphy, patination	<ul style="list-style-type: none"> Exclusively available with round spray nozzles Reusable cup
4.3 SATAgraph 1/2/3 Page 42 43 	Spray guns for custom design in craft and industry	<ul style="list-style-type: none"> Airbrush guns with gravity or suction cups Exclusively available with round spray nozzles With double-action function
4.4 SATAgraph 4 B/S/H Page 44 45 	Spray guns for custom design in craft and industry	<ul style="list-style-type: none"> Airbrush guns with gravity, side or suction cups Exclusively available with round spray nozzles With double-action function Reversing nozzle for fine detail work

5. Automatic & Robotic Guns		
Spray gun type	Fields of applications	
5.1 SATA automatic and robotic Page 47 - 77 	Industrial application of varying amounts of materials. Please inquire for specific usage and combinations available	

Discontinue spray guns, parts available, page 66 - 80
If you do not find your spray gun, visit www.satausa.com

Cutaway model SATAjet 4000 B

Cutaway model SATAjet 4000 B

Robust air cap of chrome-plated brass with new **QC™** air cap thread for quick change with only one turn.



Air cap ring:

green = HVLP technology

blue = RP technology



Fluid tip and paint needle made of corrosion resistant stainless steel.

Material passage (red).

Air passage (blue).

Replaceable air distribution insert.

Fluid tip sealing ensuring minimal cleaning effort and safe colour change.

Low maintenance, self-adjusting paint needle sealing.

Low maintenance, self-tensioning air piston packing.

Wear resistant air piston.

Ergonomically designed trigger with paint needle protection ensuring increased lifetime of the paint needle packing.

Option: Digital pressure display for perfect colour match.



CCS™ – Colour Code System. For the convenient identification of your spray gun.



QCC™ – Quick Cup Connector. Bayonet cup connection. Ensures quick and clean cup changes as well as easy cleaning.

Gun suspension hood for convenient storage.

Control elements can be perfectly adjusted even when wearing gloves.

Improved material flow control with counter nut.

Air micrometer for the adjustment of the atomisation air. Highest precision with digital pressure gauge (optional).



Easy to adjust round/flat control: **Quarter turn**. Switching back and forth from round to flat spray fan with only a quarter turn.

Spray gun body made of drop-forged aluminum. Ergonomically shaped gun handle.







Easy clean corrosion-resistant chrome gun surface.

Air connection G 1/4 male thread with optionally available swivel joint.





Warranty. Top quality is not enough - we guarantee it: for three years!

Application Recommendations for Cup Systems

Cup Systems 85-94		
Cup type / capacity	Fields of application	Connection
<p>SATA RPS mixing cup 0,3 l / 0,6 l / 0,9 l Page 86 87 88</p> 	<p>Disposable gravity cup with paint sieve for frequent colour changes. For mixing, painting and storing. No adapters required for all current SATA spray guns</p>	<ul style="list-style-type: none"> • With QCC bayonet lock and male thread • Adapters for older SATA spray gun models and spray guns from other manufacturers are available
<p>SATA RPS Adapters Page 89</p> 	<p>Use RPS adapters for spray guns without QCC adapters. Also for paint guns of other spray gun manufacturers</p>	
<p>SATA reusable cup 63 ml / 15 ml / 0.3l / 0.6 l / 0.75 l / 1.0 l Page 90 91</p> 	<p>Reusable plastic or aluminum gravity flow cups for SATA spray guns</p>	<ul style="list-style-type: none"> • With QCC bayonet lock and male thread or with female thread for older SATA spray gun models
<p>SATA glass reusable cup 25 ml Page 92</p> 		
<p>SATA cup adapters Page 92</p> 		
<p>SATA BVD adaption kit 0,7 l Page 93</p> 	<p>Pressurised reusable aluminum gravity flow cup for the application of high-viscosity materials</p>	<ul style="list-style-type: none"> • With QCC bayonet lock and male thread or with female thread for older SATA spray gun models
<p>SATA agitator cup 0,7 l Page 94</p> 	<p>Reusable aluminum gravity flow cup with integrated agitator for the application of materials with settling components, e.g. effect paints. Agitator with air regulation valve for speed adjustment</p>	<ul style="list-style-type: none"> • With QCC bayonet lock and male thread

Application Recommendations for Breathing Protection

Breathing Protection 98-113

Respirator type		Fields of application/function
SATA vision 2000 Page 98 102		Full face respirator protects the head incl. hair and neck / <u>independent</u> from ambient air (air supplied). Please note the legal requirements of your region.
SATA air star C Page 100 104		Half mask protects mouth and nose / <u>independent</u> from ambient air (air supplied). Protective goggles are recommended. Please note the legal requirements of your region.
SATA air star F Page 108		Half mask to protect the mouth and nose area / <u>dependent on ambient air</u> (filtering mask). With pre-filter disks to extend the lifetime of the filter cartridges. It is recommended to wear protective goggles. Please note the legal requirements of your region.

Cutaway SATA vision 2000



Head/chest cover with velcro closure; breathable, solvent-resistant, lint-free and flame retardant.

Individually adjustable head strap to allow greater wearer comfort.

Adjustment screw allowing to fix the visor.

Lightweight, robust liftable visor.

Sweat band made of microfibre velour, dermatologically tested; easy to replace to ensure highest hygiene standards; with foam insert for enhanced wearer comfort.

Hygienic quick exchange hood inlays.

Special single visor foil to prevent reflections and distortions leading to colour deviations; quick and easy to change.

Breathing air hose with sound adsorber for fresh air supply.

■ SATA® Belt Units
Adjustable and cushioned;
a) with activated charcoal adsorber to provide breathing air quality.
b) Industrial belt unit

■ SATA® top air™
Breathing air humidifier for a comfortable breathing climate, attaches to the belt unit.

■ SATA® air warmer
Adjustable breathing air warmer to increase the temperature by max. approx. 13 °C, attaches to the belt unit.

Sound adsorber

Application Recommendations for Filtration Technology

Filtration Technology 114-124

Filter type

SATA filter
424 / 434 / 444 /
464 / 474 / 484
 Page 112-115



Fields of application/function

- Filter units for the use in paint booths
- Ambient temperature: **up to max 248 °F,**
or up to max 140 °F when using activated charcoal (3 stage)
 - Modular structure of up to 3 filter stages incl. activated charcoal filter
 - Meets highest requirements for high-grade compressed air (100 % technically clean air)
 - Air flow: **129 cfm @ 90 psi**

SATA filter

222 / 224 / 244 /
284
 Page 116 | 117



- Filter units for the use in paint booths
- Modular structure of up to 3 filter stages incl. activated charcoal filter
 - Ambient temperature: **up to max 120 °C,**
or up to max 140 °F when using activated charcoal (3 stage)
 - Meets requirements for high-grade compressed air (100 % technically clean air)
 - Air flow: **70 cfm @ 90 psi**

Cutaway model SATA filter 484

Large pressure adjustment screw allowing the exact regulation of the work pressure.

Maintenance free pressure regulation valve.

Air inlet G 1/2 female thread : Air flow > 3,600 NI/min at 6.0 bar or 87 psi (for 400 series)

First filter stage:

■ Low maintenance cyclone separates condensate and oil droplets

■ Sintered filter to separate particles > 5 micron; exchange interval: 6 months

Automatic condensate discharge valve - high operating safety, low service effort.

Condensate discharge hose.

Air pressure gauge for pressure difference display (control of fine filter saturation).

Air outlet module.

Optional air outlet G 1/2 female thread

Air outlets with ball valves and connections w/ G 1/4 male threads

Filter housing with easy clean surface.

Second filter stage:

■ Fine filter cartridge to separate particles > 0.01 micron; separation efficiency 99.998 %; exchange interval: 6 months

Third filter stage:

■ Activated charcoal cartridge to eliminate oil vapours when using air-supplied breathing masks and for the application of waterborne paints; Exchange interval every 3 months.

Application Recommendations for Other Devices / Accessories



1. Spray Gun Cleaning

Type of Device	Fields of application/function
2.1 SATA clean RCS Page 124 	<ul style="list-style-type: none"> • Rapid cleaning system for intermediate cleaning of spray guns for quick colour changes when using disposable cups, e.g. SATA RPS • Suitable for waterborne and solvent-based paint systems

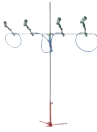
2. Dry-Blowing Systems

Type of Device	Fields of application/function
3.1 SATA dry jet Page 126 	<ul style="list-style-type: none"> • Accelerated drying for surfaces painted with waterborne materials • Ideally suited for smaller paint jobs, as expensive booth heating times are being avoided
3.2 SATA dry jet jumbo Page 126 	<ul style="list-style-type: none"> • Use of multiple blow guns enhances productivity • Complete with four blow guns for larger surfaces e.g. for commercial vehicles

3. Bodyshop Equipment

Type of Device	Fields of application/function
4.1 SATA Blow Guns Page 130 	<ul style="list-style-type: none"> • To blow-off dust and particles - low air consumption, high efficiency • Sturdy and very durable • Different versions with special nozzle set-ups available
4.2 Grit Blasting Equipment Page 130 	<ul style="list-style-type: none"> • Grit blasting guns with hard metal insert to remove rust efficiently and quickly • Ideal for difficult to access areas. • Injector suction principle optionally with hand-held gun or large containers
4.3 Rust Proofing Equipment Page 132 - 135 	<ul style="list-style-type: none"> • Pressurised cup spray gun for cavity preservation and underbody protection of all vehicle types. Different cavity wand systems are available. • Fine atomisation even with the application of high-viscosity materials by pressurisation with up to 150psi

4. Material Supply for Spray Guns

Type of Device	Fields of application/function
1.1 SATA vario top spray Page 136 - 140 	<ul style="list-style-type: none"> • Pneumatically operated low pressure double diaphragm pump for air atomising pressure fed spray guns or material supply for automatic spray guns, directly out of the original container

Dan-Am Application Recommendations for Other Devices / Accessories

Dan-Am Products 142-184		
Type of Device		Fields of application/function
Dan-Am Air Page 144-145		DanAm Air is a an aluminum compressed airlines that is easily installed with the push to connect technology, is modular, can be connected to existing airlines.
Carbon Monoxide Monitors Page 146-147		Both AC and DC, wall mount and portable CO monitors meet the OSHA and NIOSH regulations. Alert at 10 ppm, both audible and visible alarm and led readouts.
Dan-Am Cabinets and Spray Gun Holders Page 148		Unique locking cabinets to store valuable SATA spray guns. Both single and dual door options. We also offer a full line of gun holders useful in any shop.
Electric Drain Valve Page 148		Inexpensive way to insure your air tank or airline system is purged of condensation. Two timers set how often it drains, and purge cycle length
Dan-Am Air Vac Page 149		This handy tool helps eliminate dirt & debris from your wet clearcoat or topcoat. Saves great amount of time and redo work later.
Easy Flex Paint Stand Page 150-153		Flexible efficient easy to use panel stands to paint panels, bumpers, wheels and small parts from nearly every direction
Dan-Am Blow Dryer Stands Page 128-129		Economical versions of stands to hold single or multiple SATA dryjet blow guns. Speeds the drying process of waterborne paint and lets the painter walk away
Dan-Am How-To DVDs and Books Page 154		Assortment of how-to books and DVD from various artists and painters. Learn to do it from the pros using SATA equipment
Dan-Am Paint Suits Page 155		A variety of sizes and design paint suits from economical to professional series . Flexible for comfort and anti-static to keep your work and you clean
Dan-Am SATAwear Page 156-157		Wear SATA gear proudly. Check with us often for additions to the Dan-Am and SATAwear products
Dan-Am Pro Stencils/Sticky Mickey Masking Page 158-159		Creative and functional as well as high quality at a great low price stencils and Sticky Mickey masking help all your custom work look amazing
Dan-Am Sales and Demo Support/Cases Page 160		Extremely durable cases to provide protection and ease of transporting your SATA spray guns. Various sized cases available for any needs
Dan-Am Hoses Page 161		Hoses for everything from breathing air to high pressure fluid and air combination hoses for painting
Dan-Am Pressure Pots Page 162--163		High quality pressure pots for fleet and commercial use. Include options for pressure tank and SATA spray gun combinations and hoses
Dan-Am 10-20 L Pressure Tanks Page 164-167		Pressure tanks and hoses with various options for single and dual gauges, dingle and dual guns and economical for the value minded budget
Dan-Am Pressure Regulators Page 168-169		Pressure regulators for pressure pots and tanks for a variety of sizes and setups
Dan-Am Piranha 338 SS 1:1 Pump Page 170-171		1:1 diaphragm stainless pump for commercial use. For use with low viscosity water products to high viscosity urethanes. Easy to maintain
Dan-Am 7232 High Pressure Pump Page 172-175		Stainless Steel high pressure air assisted airless pump for use with high viscosity or multiple gun applications
Dan-Am 2710 Med. and 2733 High Pres. Pump Page 176-179		10:1 and 33:1 stainless pumps for use with a variety of viscosities and products. 27cc lower allows up to 2 gun connections
Dan-Am Air Assist Pump System Order Form Page 180		Makes it easy to determine the pump you want, and place an order
Dan-Am 5 Gallon Agitator Lid Page 181		Complete stainless steel suitable for waterborne or solvent materials. Durable GAST Air Motor construction with complete speed variability
Dan-Am Brochures, Decals and Posters Page 184		Complete range of product brochures, posters and decals from SATA and Dan-Am Company



Spray Guns



SATAjet® 4000 B RP®/HVL



Use for high-quality topcoat finishes in automotive or any other field of application. Superb finish results, along with a well-balanced, light-weight, ergonomic spray gun are a few of the design factors built into the SATAjet 4000 B. With enhanced atomization and a wider, softer fan, it delivers superior finish quality. Material distribution is improved and transfer efficiency far exceeds 65% required by legislation for both HVL and RP. With a newly designed nozzle concept, every paint system is safely and perfectly applied. With extremely uniform and soft spray fan, the material lays down smoothly, resulting in a top class finish.

With the new ergonomic design, the control elements can easily be adjusted. The fan control is now fully adjustable with only 1/4 of a turn from open to close. New trigger design with less trigger pull means the painter can use one, two or three fingers for fatigue-free work. The control adjustments and gun body have a high-gloss chrome finish for corrosion protection. Moreover, the material passages have a special coating to enhance internal corrosion protection making the SATAjet 4000 B suitable for waterborne or solvent base material.

The DIGITAL model with LCD readout integrated into the gun handle gives you a precise pressure setting to achieve exact color matches.

SATAjet 4000 B RP DIGITAL & Standard

Technical Data	Inlet Pressure: 2.0 - 2.2 bar / 29-35 psi									
	Air consumption: 2.0 bar: 285 NI/min / 10.4 cfm at 29 psi									
	Spray distance: 17 - 21 cm / 6 3/4 - 8 1/4 in									
	Weight: 20 oz.									
Nozzle	1.0	1.1	1.2	1.2 W	1.3	1.4	1.6	1.8	2.0	2.5
Standard gun with RPS demo pack										
Order No.	176974	171520	169979	169987	169995	170001	176990	177014	177030	177055
DIGITAL gun with RPS demo pack										
Order No.	176982	171553	170019	170027	170035	170050	177006	177022	177048	177063
Nozzle	1.0	1.1	1.2	1.2 W	1.3	1.4	1.6	1.8	2.0	2.5
Nozzle Set										
Order No.	166991	167007	167015	167023	167049	167056	167072	167080	168625	168633



SATAjet 4000 B HVL DIGITAL & Standard

Technical Data	Inlet Pressure: 2.0 bar / 29 psi									
	Air consumption: 2.0 bar: 430 NI/min / 15.2 cfm at 29 psi									
	Spray distance: 10 - 15 cm / 4 in - 6 in									
Nozzle	1.0	1.2	WSB	1.3	1.4	1.4HC	1.5	1.7	1.9	2.2
Standard gun with RPS demo pack										
Order No.	176891	170159	170167	170175	170209	170217	170696	176917	176941	176958
DIGITAL gun with RPS demo pack										
Order No.	176909	166249	170357	170365	170399	170407	170704	176925	176933	176966
Test Air Cap	171355		171348				Call			
Nozzle	1.0	1.2	WSB	1.3	1.4	1.4HC	1.5	1.7	1.9	2.2
Nozzle Set										
Order No.	166926	166934	166983	166942	166967	171512	166975	168658	168666	168674
Specially Developed HVL Nozzles				1.3 C	1.3 LV					
Standard gun with RPS demo pack										
			170183	170191						
DIGITAL gun with RPS demo pack										
			170373	170381						
Test Air Cap			171348	171355						
Nozzle Set			166959	168641						

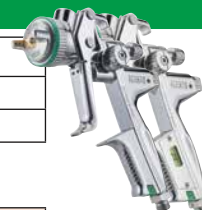

Technical modifications and printing errors reserved

Spare Parts SATAjet® 4000 B

Order No./Desc.	
240	Packing, air piston
1818	Snap ring, air cap
3426	Circlip, pin, ea.
3970	Seal, air micrometer
14605	Bushing, needle packing
14993	Spring, needle packing
15438	Kit, needle packing
17897	Spring, paint needle
19745	Swivel fitting, standard 1/4" air inlet
23275	Packing, needle
27813	Spring, air piston
53470	Pad, rubber trigger
54775	Pad, rubber trigger , pk of 5
69872	O ring, fan control
82552	Kit, air piston service
86843	Piston, air rod
96875	Seal, inner cup
133934	O ring, fan control, pk of 3
133942	Bushing, air piston
133959	Kit, spring, pk of 3 each of #27813 & #17897
133967	Pin, air micrometer, pk of 3
133991	Packing, air piston, pk of 3
134098	Fitting, standard 1/4" air inlet, non-digital
136960	Packing kit
140582	Seal, Fluid Tip, pk of 5
164459	Knob, fan control
164574	Screw, fan control
164623	Pin, upper trigger
164624	Pin, lower trigger
164376	Blue ring only for air cap
164384	Green ring only for air cap
165928	CCS clips, pk of 4
165936	Tool kit
165944	Control Spindle, w/O ring
165951	Air distribution ring, pk of 3
165977	Trigger kit
165993	Battery Kit w/cover and seal
166009	Kit, trigger sleeve
166017	Air micrometer (air flow control)
166025	Material flow control w/counter nut
166033	Knob, fan control w/screw
166058	Repair kit
166330	Trigger only
166371	Ring only, RP 4000 air cap
166389	Ring only, HVLP 4000 air cap
167882	Washer, tension spring
172429	Seal, air cap ring, pk of 5

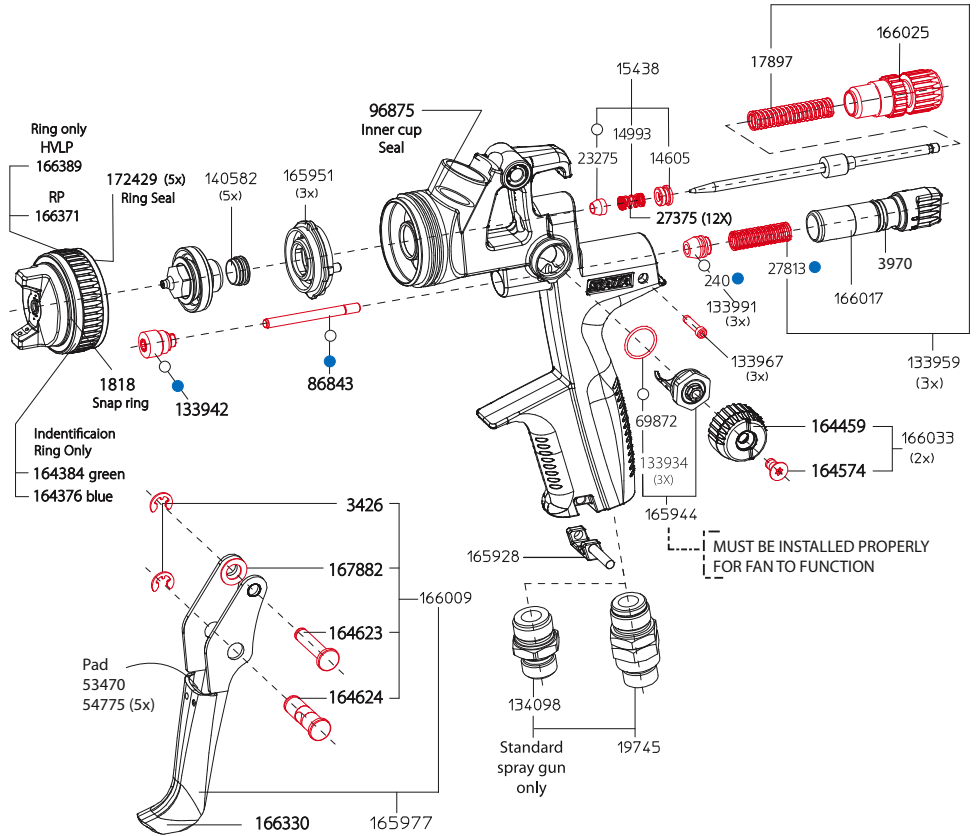

WARNING
 on DIGITAL GUNS
 Removing the DIGITAL air inlet tube or the DIGITAL display cover
 VOIDS WARRANTY
 It must be returned for service
 otherwise it will not function properly

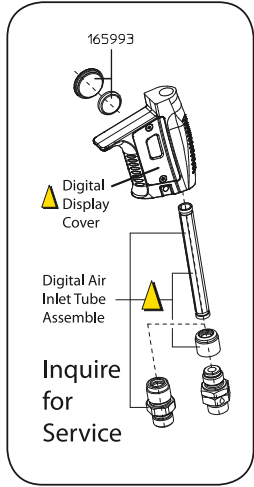

165936 Tool Kit	
901	Universal spanner wrench
3509	Cleaning brush
64543	Allen wrench
9647	Allen/Torx wrench T20
	Paint sieve
43638	Extraction tool



Order No./ Desc.
166058
Repair kit
82552
Air piston service set
136960
Sealing kit

Technical modifications and printing errors reserved

SATAjet® 3000 K RP®/HVLP



Use for high quality topcoat finishes in automotive, fleet or any industrial application.

The SATAjet® 3000 K™ HVLP offers the finest atomization and a top-class finish and achieved by SATA® technology, ensures transfer efficiencies considerably above 65 % required by VOC legislation. The patented air circulation principle provides an especially homogeneous and soft fan. The large fan and high material flow rates ensure swift work. Excellent ergonomics - the short gun body, extremely low weight and the optimum balance ensure the gun "fits like a glove". Suitable for water-borne materials - paint needle and nozzle are made of stainless steel, and the nickel-plated gun body has been refined with a special coating. The durable air caps are made of brass (not of aluminium), therefore ensuring a long life time - a factor particularly important for industrial use.



SATAjet 3000 K RP

Technical Data	Inlet pressure: 2.5 bar - 3.0 bar / 36-43 psi
	Air consumption: 2.5 bar:430 NI/min / 15.2 cfm at 36 psi
	Spray distance: 15 - 23 cm / 6 - 9 in
	Material connection: G 3/8 male thread

Nozzle	0.8	1.1	1.3	1.5	1.7	2.0
---------------	-----	-----	-----	-----	-----	-----

Standard gun Standard (STD) or Specially Treated (ST) Nozzle

Order No. STD	92932	93336	93344	93351	93369	93377
Order No. ST	163022	141994	142265	166421	93369ST	137844

Standard gun with DIGITAL SATAadam 2, Standard (STD) or Specially Treated (ST) Nozzle

Order No. STD	92692	93120	93138	93146	93161	93179
Order No. ST	92692ST	137869	137877	93146ST	93161ST	93179ST

Nozzle	0.8	1.1	1.3	1.5	1.7	2.0
---------------	-----	-----	-----	-----	-----	-----

Nozzle Set - Standard (STD) or Specially Treated (ST)

Order No. STD	92494	92502	92510	92528	95422	95356
Order No. ST	141317	137901	137919	137927	137935	137943



SATAjet 3000 K HVLP

Technical Data	Inlet pressure: 2.5 bar / 36 psi
	Air consumption: 2.5 bar:560 NI/min / 18.7 cfm at 36 psi
	Spray distance: 13-17 cm / 5 - 8 1/2 in
	Material connection: G 3/8 male thread

Nozzle	0.8	1.0	1.2	1.4	1.6	2.0
---------------	-----	-----	-----	-----	-----	-----

Standard gun with Standard (STD) or Specially Treated (ST) Nozzle

Order No. STD	93385	92924	93393	193656	96164	96172
Order No. ST	93385ST	92924ST	93393ST		137851	96172ST

Standard gun with DIGITAL SATA adam 2, Standard (STD) or Special Treated (ST) Nozzle

Order No. STD	93286	92718	93294		96149	96156
Order No. ST	93286ST	92718ST	93294ST		96149ST	96156ST

Test Air Cap	95059	95067				
---------------------	-------	-------	--	--	--	--

Nozzle	0.8	1.0	1.2	1.6	2.0
---------------	-----	-----	-----	-----	-----

Nozzle Set - Standard (STD) or Specially Treated (ST)

Order No. STD	92783	92791	92809	92817	92825	STD = Standard
Order No. ST	147058	137950	137968	137976	137984	ST = Special Treated
Order No. HM	-	-	58396	59626	61408	HM = Carbide (hard metal)
Test Air Cap	95059	95059	95067	95067	95067	

Technical modifications and printing errors reserved

Spare Parts SATAjet® 3000 K

Order No./Desc.	
240	Air piston packing
1503	Fan control screw
3426	Circlip only, 1 each
3624	Pin, micrometer
3699	Pin, lower trigger
6981	Female nipple, pk of 5
7757	ColorCode disc, pk of 4
10033	Air cap ring w/seal, 3000 K RP
12591	Pin, upper trigger
13656	Female nipple (German)
14605	Bushing, needle packing
14985	Battery kit, digital
14993	Spring, needle packing
15438	Needle packing service set
17525	Lock spring
17897	Needle spring
23275	Needle packing
27813	Air piston spring
38265	Material filter, R 3/8
38638	Air ring, K3000 K, HVLP and RP
38638-3	Air ring, pk of 3
38638-5	Air ring, pk of 5
38638-20	Air ring, pk of 20
43638	Wire tool, air ring
50542	Lock nut fluid control
53470	Trigger slider pad
53603	Air micrometer
82636	Air piston packing holder
91108	QC nipple
91140	QC w/nipple
91157	QC w/filter and nipple
91835	Knob, fan control
91884	Trigger
91959	Air piston, 3000 K
92031	Paint pipe, 3000 K, R 3/8
92049	Fan control
92056	Trigger service set
92577	Tool set, 3000 K
92619	Fluid control service set
92742	Fan control service set
92759	Air piston service set
92767	Repair kit, 3000 K HVLP & RP
93732	Air cap ring w/seal, 3000 K HVLP
95091	Air inlet fitting, Digital
133926	Kit, trigger sleeve
133942	Air piston packing
133959	Kit, spring, pk of 3 each of #27813 & #17897
133967	Pin, air micrometer, pk of 3
133991	Packing, air piston, pk of 3
134098	Air inlet fitting, 1/4" BSP
143834	Seal, air cap ring, pk of 5
183780	Seal kit

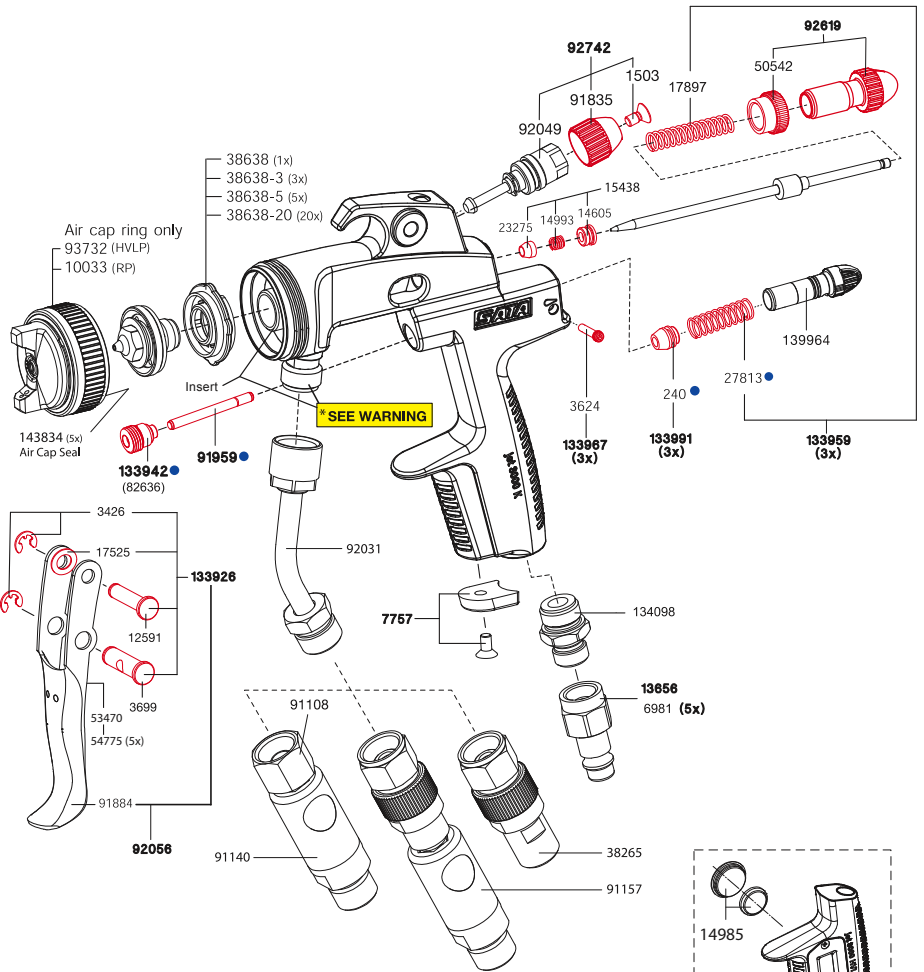

***WARNING**
Do not remove the insert, seal, and fluid inlet. Special tools are required.

Insert

Seal

Fluid Inlet

CALL SATA repair department for details.

⚠ WARNING on DIGITAL GUNS
Replacing part number 95091 or removing the DIGITAL display cover **IS NOT RECOMMENDED**
VOIDS WARRANTY
It must be returned for service otherwise it will not function properly

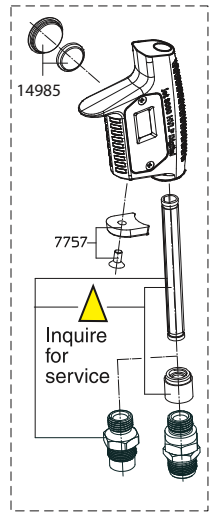

DIGITAL function is no longer in production. Parts are available. Call if servicing digital parts.

92577 Tool Kit	
901	Universal spanner wrench
3509	Cleaning brush
64543	Allen wrench 2mm
9647	Allen wrench 4mm
	Tox wrench T20
43638	Extraction tool
	Paint sieve

Order No./Desc.
92767
Repair kit
92759
Air piston service set

Technical modifications and printing errors reserved

SATAjet® 3000 K spray mix



SATAjet 3000 K spray mix

Technical Data

Max. operating pressure atomization air: 10.0 bar / 145 psi
Max. operating pressure material: 250.0 bar / 3,625 psi
Weight incl. material filter: 650 g / 23 oz.

Spray mix gun

120006	SATAjet 3000 K spray with paint pipe, strainer 100 mesh, and nozzle set (specify material nozzle size)
--------	--

Spray mix gun w/ Reversing switch

120014	SATAjet 3000 K spray with paint pipe, strainer 100 mesh, and reversing nozzle (specify reversing nozzle size)
120279	Reversing switch kit for SATAjet 3000 K spray mix w/out reversing nozzle

Using a reversing nozzle requires a "one time" purchase of the reversing switch. Part Number 120279

Nozzles - SATAjet 3000 K spray mix

Fluid tip



Reversing nozzle for reversing switch

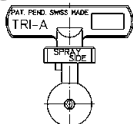

Technical Data

Nozzle No.	Order No.	Nozzle No.	Order No.	ø mm	ø inch	Angle	Width In.	oz/min @ 1015 psi		Strainer
1840	23044*			0.18	0.007	40°	7	5.41		
2325	7328			0.23	0.009	25°	6	7.78	200 msh 85 µm	74856 4 per set
2350	7435			0,23	0.009	50°	9	7.78		
2360	74922			0.23	0.009	60°	10	7.78		
		2550	120220	0.25	0.010	20°/50°	4/9	8.45		
2825	16998			0.28	0.011	25°	6	10.14		
2850	50906			0.28	0.011	50°	9	10.14		
2865	13771			0.28	0,011	65°	10	10.14		
		3050	120238	0.30	0.012	20°/50°	4/9	12.85		
3325	20206			0.33	0.013	25°	6	15.22	100 msh 150 µm	12278 4 per set
3350	50898			0,33	0.013	50°	9	15.22		
3365	13789			0.33	0.013	65°	11	15.22		
3375	74930			0.33	0.013	75°	13	15.22		
3390	73742			0.33	0.013	90°	16	15.22		
		3550	120246	0,35	0,014	20°/50°	4/9	17		
3825	13797			0,38	0,015	25°	6	20.63		
3850	7344			0,38	0,015	50°	10	20.63		
3882	74948			0,38	0,015	82°	14	20.63		
		4050	120253	0,40	0,016	20°/50°	4/9	23.6		
4650	19307			0,46	0,018	50°	9	32	60 msh 250 µm	12260 4 per set
4682	74955			0,46	0,018	82°	14	32		
5370	150276			0,53	0,021	70°	13	42		
6050	17004			0,60	0,024	50°	12	53.76		

Hose pairs see page 161

Further accessories, material and air connections see pages 26

Technical modifications and printing errors reserved

Spare Parts SATAjet® 3000 K spray mix

Order No./Desc.	
240	Air piston packing
1503	Fan control screw
3426	Circlip, pin
3624	Pin, micrometer
3699	Pin, lower trigger
12260	Sieve, 60 msh, pkg of 4
12278	Sieve, 100 msh, pkg of 4
12591	Pin, upper trigger
17525	Washer, tension spring
18341	Needle spring
27813	Air piston spring
30833	Nozzle cleaning kit
38638	Air distrib. ring, spray mix
*38638-3	Air ring, pk of 3
*38638-5	Air ring, pk of 5
*38638-20	Air ring, pk of 20
53603	Air micrometer
74856	Sieve, 200 msh, pkg of 4
82636	Air piston packing holder
91835	Knob
91959	Air piston, K3
92759	Air piston service set
98434	Pre-nozzle
98442	Seal ring, pre-nozzle
98459	Air cap, round/flat
98525	Packing holder
98541	Needle tip
98608	Paint pipe, ?, w/100 msh filter
98624	Fan control
98665	Air cap ring
98681	Trigger service set
98699	Tool kit, Sp. Mix
98707	Repair kit, Sp. Mix
98764	Pre-nozzle w/needle tip
98772	Needle w/needle tip
98806	Fan control service set
120071	Trigger lock, complete
120261	Seal, reversing nozzle
120279	Reversing switch

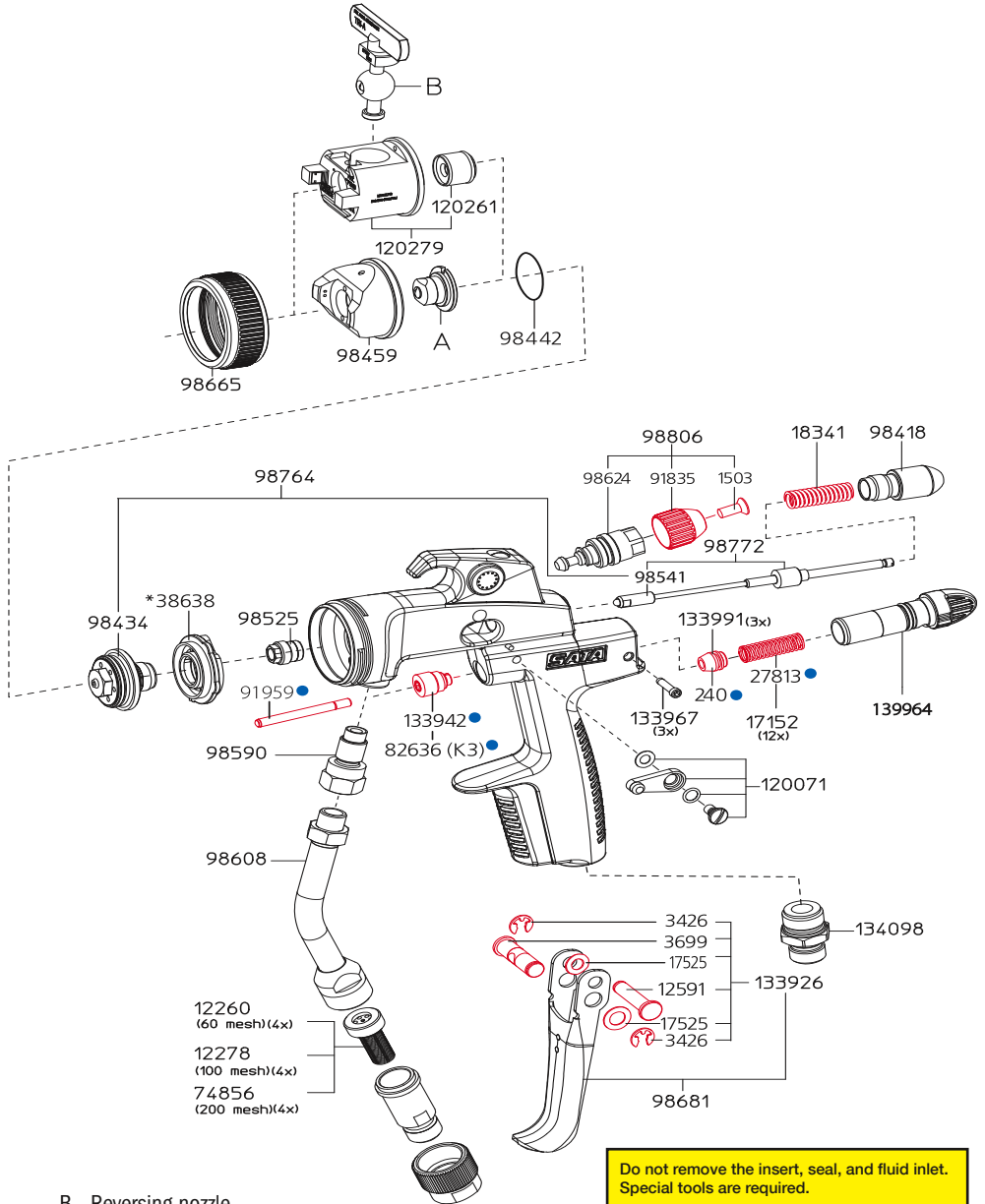

B - Reversing nozzle

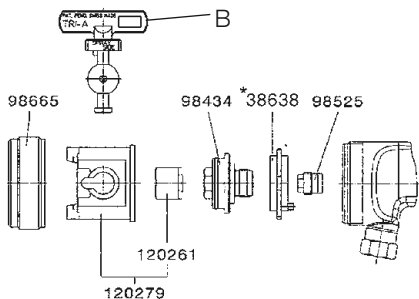

Do not remove the insert, seal, and fluid inlet. Special tools are required.

CALL SATA repair department for details.

98699 Tool Kit	
901	Universal spanner wrench
9647	Allen wrench 4mm
15925	Wrench
43638	Extraction tool
64543	Allen wrench 2mm
76307	Socket set



Using a reversing nozzle requires a "one time" purchase of the reversing switch.
Part Number 120279

Order No./Desc.
98707
Repair kit
○ 92759
Air piston service set
○ 30833
Nozzle cleaning kit

Technical modifications and printing errors reserved

SATAjet® 1000 B RP®/HVL



SATAjet 1000 B RP										
Technical Data		Inlet pressure: 1.5-2.0 bar / 21-29 psi								
		Air consumption: 2.0 bar 275 NI/min / 7.1 cfm at 36 psi								
		Spray distance: 17-21 cm / 6 1/2 - 8 1/4 in								
		Weight: 15 oz.								
		Finish: Smooth anodized								
Nozzle	0.8	1.0	1.3	1.6	1.8	2.0	2.5	3.0	4.0	5.0
Spray gun with QCC 0.6 l PVC cup										
Order No.	151183	151191	149302	149310	150391	149328	151209	151217	154161	Call
Spray gun with QCC 0.75 l aluminum cup										
Order No.	151225	151233	150342	149344	150409	149351	151241	151258	154179	Call
Spray gun with QCC 1.0 l aluminum cup										
Order No.	-	158071	158089	158097	158105	158113	158121	158139	Call	Call
Nozzle	0.8	1.0	1.3	1.6	1.8	2.0	2.5	3.0	4.0	5.0
Nozzle Set										
Order No.	151316	151324	149161	149179	150417	149187	151332	151340	154187	154195

SATAjet 1000 B D RP for glue application	
164962	SATAjet 1000 B D RP 1.6 Drall with air micrometer - spray gun for the application of glues/adhesives
164970	Nozzle set up SATA jet 1000 B D RP 1.6 nozzle set for the application of glues/adhesives



SATAjet 1000 B HVL				
Technical Data		Inlet pressure: 2.0 bar / 29 psi		
		Air consumption: 2.0 bar 350 NI/min / 12.5 cfm at 36 psi		
		Spray distance: 13-17 cm / 5 - 9 1/2 in		
		Weight: 15 oz.		
		Finish: Smooth anodized		
Nozzle	1.4	1.7	1.9	2.1
Spray gun with QCC 0.6 l PVC cup				
Order No.	149377	149385	149393	149401
Spray gun with QCC 0.75 l aluminum cup				
Order No.	149419	149427	149435	149443
Spray gun with QCC 1.0 l aluminum cup				
Order No.	158147	158154	Call	Call
Test Air Cap	157222			
Nozzle	1.4	1.7	1.9	2.1
Nozzle Set				
Order No.	149195	149203	149211	149229

Technical modifications and printing errors reserved

Spare Parts SATAjet® 1000 B

Order No./Desc.	
240	Seal, air piston
901	Wrench, universal spanner
1503	Screw, fan control
3426	Circlip, pin
3509	Brush, large standard
3624	Pin, air micrometer
3699	Pin, lower trigger
3988	Sieve, pk of 20
3988-5	Sieve, pk of 5
6395	Disc, CC (standard), pk of 4
9050	Tool set
9647	Allen wrench, 4
12591	Pin, upper trigger
14605	Bushing, needle
14993	Spring, needle bushing
15438	Kit, needle packing
17525	Washer, tension spring
17897	Spring, needle
23275	Seal, needle
27813	Spring, air piston
64543	Allen wrench, 2
69872	O-ring, fan control
82826	Kit, air piston service set
89771	Control, RH w/O-ring
91959	Air piston
92577	Tool set
96875	Seal, inner cup
130146	Air micrometer, DIGITAL
130393	Seal, air cap ring
130435	Air cap ring only (RP)
130443	Air cap ring only (HVLP)
130492	Trigger kit
130542	Repair kit, Jet 1000 K
133926	Kit, trigger sleeve
133934	O-ring, fan control, pk of 3
133942	Bushing, air piston
133959	Spring kit, 3 each of #27813 & #17897
133967	Pin, air micrometer, pk of 3
133983	Fitting, air inlet, R ?
133991	Seal, air piston, pk of 3
134031	Knob, fan control w/screw, 2 pk
139188	Kit, fluid control and lock nut
139964	Air micrometer, standard
140574	Knob, fan control w/screw
140582	Seal, fluid tip, pk of 5
143230	Air distribution ring, pk of 3
183780	Seal kit

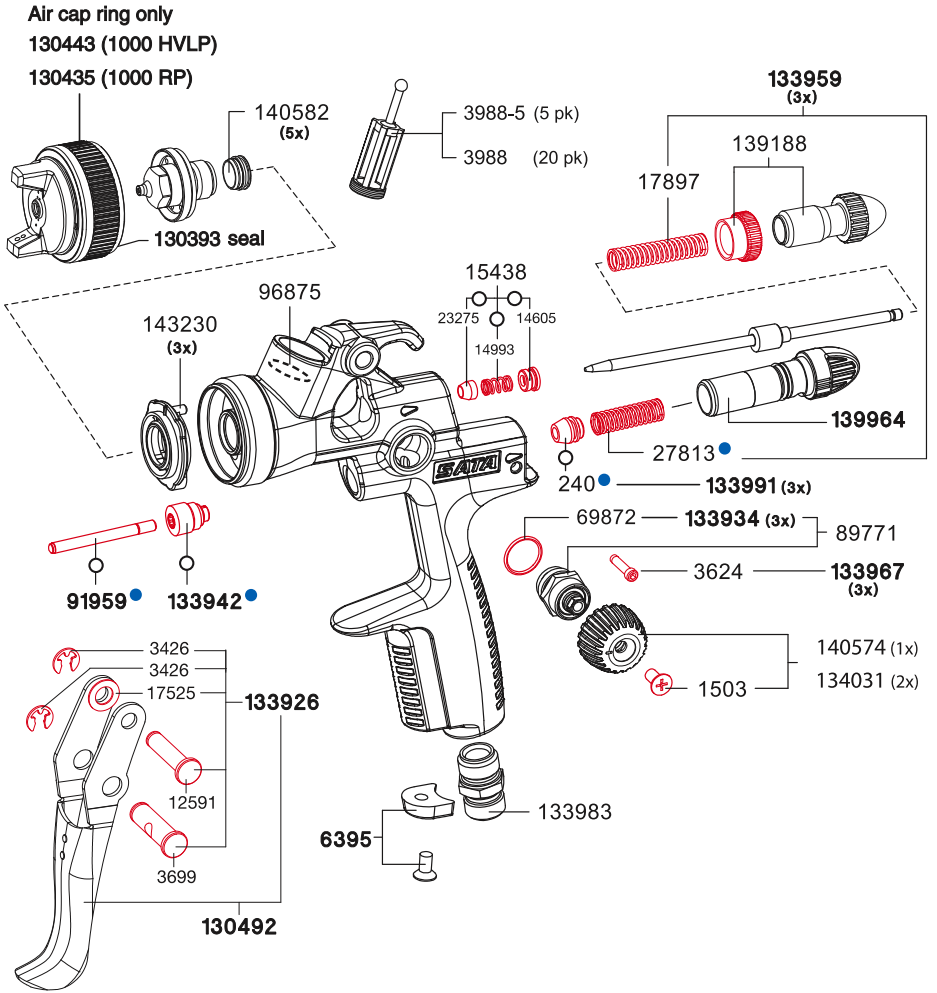

Technical modifications and printing errors reserved

9050 Tool Kit

901	Universal spanner wrench
3509	Cleaning brush
9647	Allen/Torx wrench
64543	Allen wrench
43638	Extraction tool



Order No./Desc.

130542	Repair kit
92759	Air piston service set
183780	Sealing Kit

SATAjet® 1000 K RP®/HVLP





SATAjet 1000 K RP											
Technical Data			Inlet pressure: 36 psi								
			Air consumption: 14.5 cfm at 36 psi								
			Spray distance: 7 - 9 in								
			Material connection: G 3/8 exterior thread								
Nozzle	0.8	1.1	1.3	1.5	1.7	2.0	2.5	3.0	4.0	5.0	
Standard gun with Standard (STD) or Specially Treated (ST) Nozzle											
Order No. STD	132092	132100	132118	132126	132134	132142	153486	153494	154336	-	
Order No. ST	141903	141911	141929	141937	141945	141952	-	-	-	-	
Nozzle	0.8	1.1	1.3	1.5	1.7	2.0	2.5	3.0	4.0	5.0	
Nozzle Set											
Order No. STD	132159	132167	132175	132183	132191	132209	153528	153536	154377	154385	
Order No. ST	141648	141655	141663	141689	141697	141705	159442	-	-	-	
Extensions see page 28											

SATAjet 1000 B D RP for glue application	
161232	SATAjet 1000 K D RP 1.6 Drall with air micrometer - spray gun for the application of glues/adhesives
159707	Nozzle set up SATA jet 1000 K D RP 1.6 nozzle set for the application of glues/adhesives

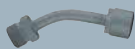

SATAjet 1000 K HVLP											
Technical Data			Inlet pressure: 36 psi								
			Air consumption: 18.7 cfm at 36 psi								
			Spray distance: 5 - 8 in								
			Material connection: G 3/8 exterior thread								
Nozzle	0.8	1.0	1.2	1.4	1.6	2.0					
Standard gun with Standard (STD) or Specially Treated (ST) Nozzle											
Order No. STD	139196	139204	139212	193664	139220	139238					
Order No. ST	141960	141978	141986	call	142000	142018	ST = Special treated nozzle resistant to abrasive material				
Test Air Cap	143891		143909								
Nozzle	0.8	1.0	1.2	1.4	1.6	2.0					
Nozzle Set											
Order No. STD	139253	139261	139279	Call	139287	139295					
Order No. ST	141762	141770	141804	Call	141812	141838					

Accessories for SATA pressure fed spray guns		
92031	Paint pipe for SATA pressure fed spray guns G3/8i - G3/8a version for waterborne materials	
38265	Strainer for SATA pressure fed spray guns G3/8i - G3/8a, 60 mesh, WA version	

Technical modifications and printing errors reserved

Spare Parts SATAjet® 1000 K

Order No./Desc.	
40	Seal, air piston
901	Wrench, universal spanner
1503	Screw, fan control
3426	Circlip, pin
3509	Brush, large standard
3624	Pin, air micrometer
3699	Pin, lower trigger
6395	Disc, CC (standard), pk of 4
9647	Allen wrench, 4
10520	Spring, needle, pk of 12 #17897
12591	Pin, upper trigger
14605	Bushing, needle
14993	Spring, needle bushing
15438	Kit, needle packing
17152	Spring, air piston, pk of 12 #27812
17525	Washer, tension spring
17897	Spring, needle
23275	Seal, needle
27813	Spring, air piston
38265	Material filter, R 3/8
64543	Allen wrench, 2
69872	O-ring, fan control
82826	Kit, air piston service set
89771	Control, RH w/O-ring
91108	QC nipple only
91140	QC w/nipple
91157	QC w/filter and nipple
91959	Air piston
92031	Paint pipe, R 3/8
92577	Tool set
93526	Material connection
130393	Seal, air cap ring
130435	Air cap ring only (RP)
130443	Air cap ring only (HVLP)
130484	Insert w/needle packing kit
130492	Kit, trigger
130534	Ring, air distribution, pk of 3
130534-1	Ring, air distribution, each
130542	Kit, Repair, Jet 1000 K
133926	Kit, trigger sleeve
133934	O-ring, fan control, pk of 3
133942	Bushing, air piston
133959	Kit, spring, 3 each of #27813 & #17897
133967	Pin, air micrometer, pk of 3
133983	Fitting, air inlet, R ?
133991	Seal, air piston, pk of 3
139188	Kit, fluid control and lock nut
139964	Air micrometer, standard
140574	Knob, fan control w/screw
140582	Seal, fluid tip, pk of 5
143230	Air distribution ring (3 pk)

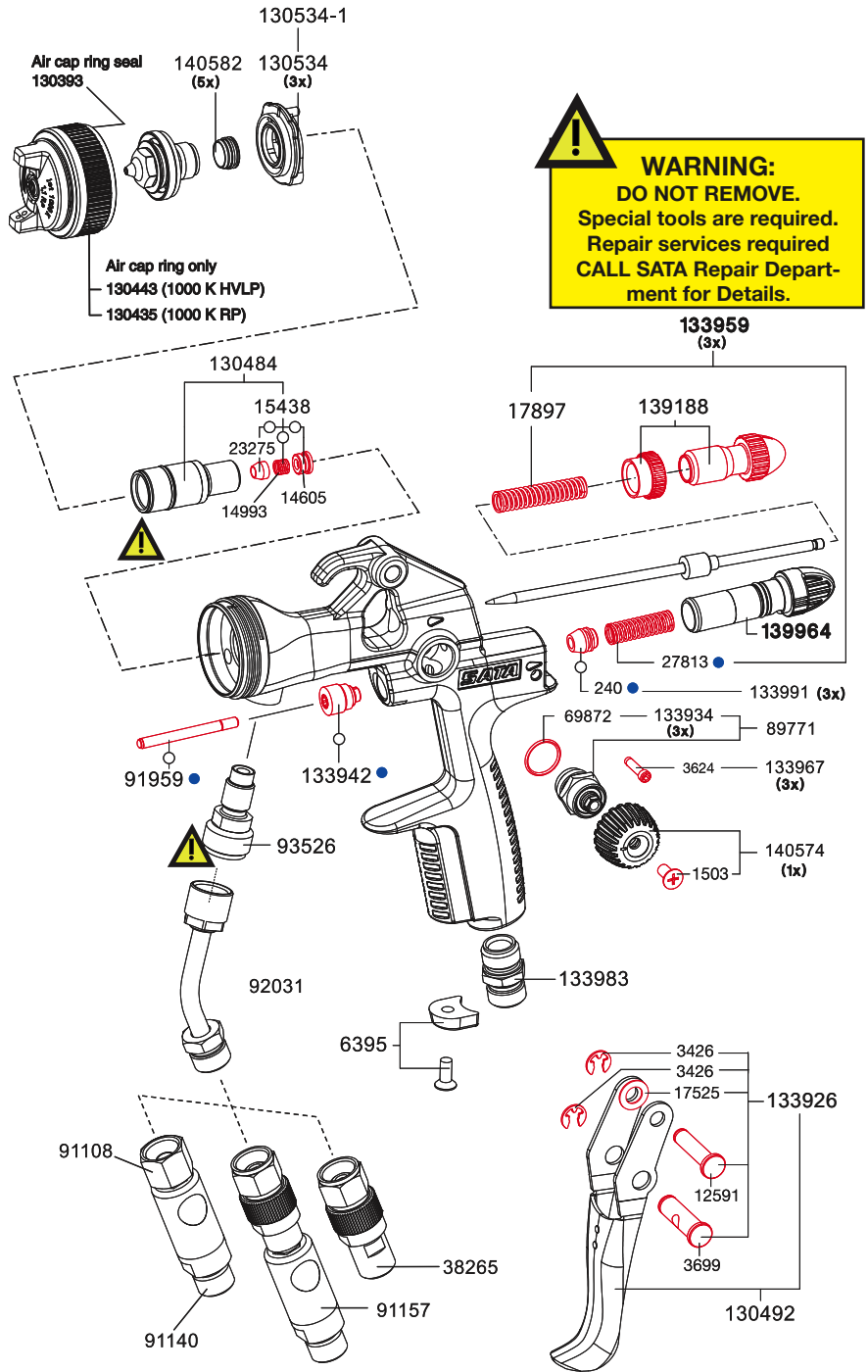

92577 Tool Kit	
901	Universal spanner wrench
3509	Cleaning brush
9647	Internal hex wrench
64543	Allen wrench
43638	Extraction tool

Order No./Desc.	
130542	Repair kit
92759	Air piston service set
183780	Sealing Kit

Technical modifications and printing errors reserved

SATAjet® 1000 K Specialty Spray Guns

SATAjet 1000 K D RP

The SATAjet 1000 K is available in a special version for the application of glues/adhesives with round fan. This nozzle set has a nozzle size of 1.6. Available with or without fan control



Technical Data

Inlet pressure: 1.5 - 2.5 bar / 29 psi

Air consumption: 2.0 bar: 275 NI/min / 9.7 cfm at 29 psi

Spray distance: 18-23 cm / 7 - 9 in

Nozzle 1.6

Standard with round fan control

Order No. 161232

Standard without round fan control

Order No. 158535

Nozzle 1.3

Nozzle Set

Order No. 161059

SATAjet 1000 K Slit Nozzle

The SATAjet 1000 K RP slit nozzle is used for high viscosity material. In the construction trade it is used for spraying spatter for a textured finish.



Technical Data

Inlet pressure: 1.5 - 2.5 bar / 29 psi

Air consumption: 2.0 bar: 275 NI/min / 9.7 cfm at 29 psi

Spray distance: 18-23 cm / 7 - 9 in

Nozzle 25/55° 3.0/55° 4.0/79°

Standard

Order No. 154344 154351 154369

Nozzle 25/55° 3.0/55° 4.0/79°

Nozzle Set

Order No. 154393 154401 154419

SATAjet 1000 RP KK HKU Undercoating

Spray gun with round fan nozzle for the SATA HKU barrel pump system. Air connection 1/4" thread. Supplied complete with Type 1 #8359 material quick coupling for wands (material pip not included, order separate)



Technical Data

Inlet pressure: 1.5 - 2.5 bar / 29 psi

Air consumption: 14.5 cfm at 36 psi

Nozzle 1.5

Standard

Order No. 153700

Technical modifications and printing errors reserved

Parts SATAjet 1000 KK

Order No./Desc.	
240	Seal, air piston
901	Wrench, universal spanner
3426	Circlip, pin
3509	Brush, large standard
3624	Pin, air micrometer
3699	Pin, lower trigger
6395	Disc, CC (standard), pk of 4
8359	Wand coupling, small, Type I
9647	Allen wrench, 4
12591	Pin, upper trigger
14605	Bushing, needle
14993	Spring, needle bushing
15438	Kit, needle packing
17525	Spring, spacer lock
17897	Spring, needle
23275	Seal, needle
25486	Round spray nozzle, Type I
25874	O Ring, 9 x 1.5, end cap
27813	Spring, air piston
31336	Paint pipe, R 3/8 to 1/4 air hose
64543	Allen wrench, 2
78154	End plug
82826	Kit, air piston service set
91959	Air piston
92577	Tool set
93526	Material connection
130393	Seal, air cap ring
130435	Air cap ring only (RP)
130484	Insert w/needle packing kit
130492	Kit, trigger
130534	Ring, air distribution, pk of 3
130534-1	Ring, air distribution, each
130542	Kit, Repair, Jet 1000 K
133926	Kit, trigger sleeve
133942	Bushing, air piston
133959	Kit, spring, 3 each of #27813 & #17897
133967	Pin, air micrometer, pk of 3
133983	Fitting, air inlet, R ?
133991	Seal, air piston, pk of 3
139188	Kit, fluid control and lock nut
140582	Seal, fluid tip, pk of 5
143230	Air distribution ring (3 pk)
153718	Mixing nozzle

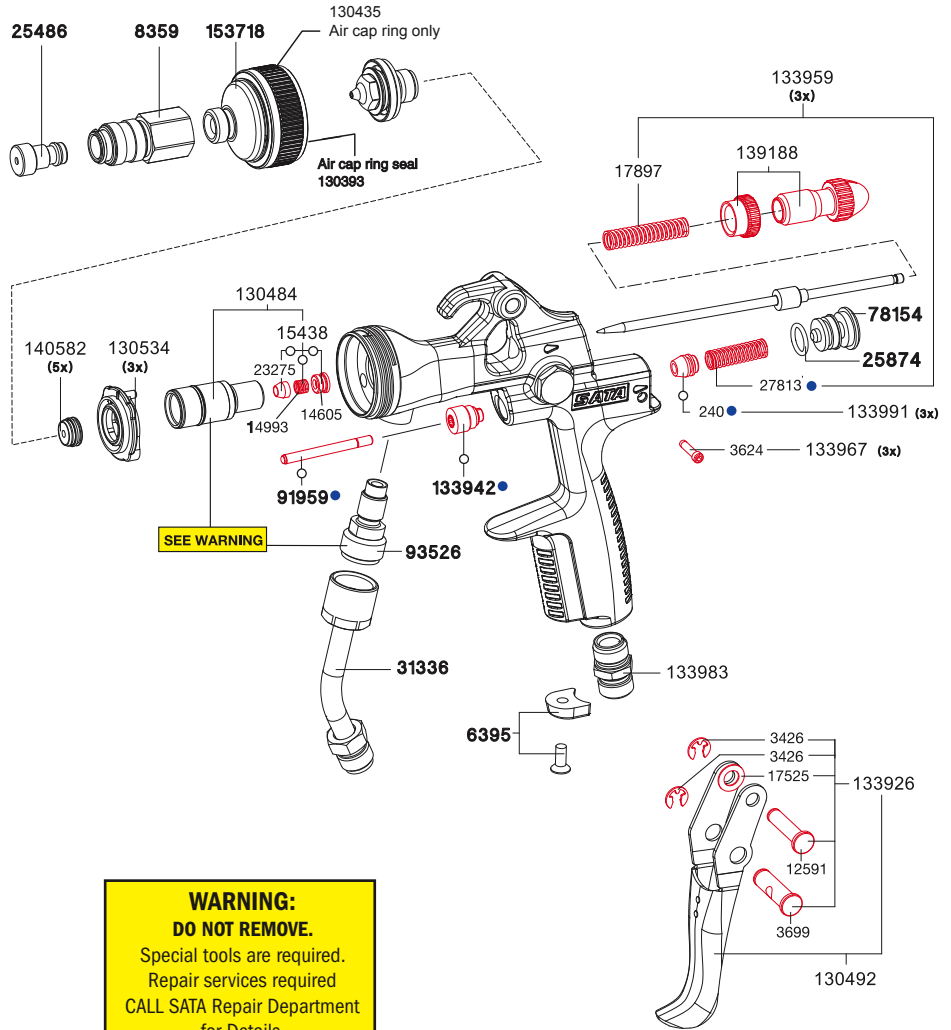

92577 Tool Kit	
901	Universal spanner wrench
3509	Cleaning brush
9647	Internal hex wrench
64543	Allen wrench
43638	Extraction tool

Order No./Desc.
130542
Repair kit
<input type="radio"/> 92759
Air piston service set
<input type="radio"/> 183780
Sealing Kit

Technical modifications and printing errors reserved

SATAjet® 1000 H RP®



SATAjet 1000 H RP					
Technical Data		Inlet pressure: 1.5 - 2.5 bar / 29 psi			
		Air consumption: 2.0 bar: 275 NI/min / 9.7 cfm at 29 psi			
		Spray distance: 18-23 cm / 7 - 9 in			
Nozzle	1.3	1.6	1.8	2.0	
Standard with 1.0 l aluminum siphon cup					
Order No.	161034	151266	151274	153353	
Nozzle	1.3	1.6	1.8	2.0	
Nozzle Set					
Order No.	161059	151613	151621	153379	
Standard with no nozzle set					
Without nozzle set	Order no.	154930			

Accessories for SATAjet H		
188292	RPS Adapter No. 16 with QCC Connection thread G 3/8 To use for RPS siphon cup.	
188482	RPS Siphon Kit, pins, suction hose, sieve, (for 0.3L cup),pack of 25	
188516	RPS Siphon Kit, pins, suction hose, sieve, (for 0.3L cup), pack of 50	
188490	RPS Siphon Kit, pins, suction hose, sieve, (for 0.6L cup), pack of 25	
188524	RPS Siphon Kit, pins, suction hose, sieve, (for 0.6L cup), pack of 50	
188508	RPS Siphon Kit, pins, suction hose, sieve, (for 0.9L cup), pack of 25	
188532	RPS Siphon Kit, pins, suction hose, sieve, (for 0.9L cup), pack of 50	

RPS siphon cup system, "H" guns only

Technical modifications and printing errors reserved

Spare Parts SATAjet® 1000 H

Order No./Desc.	
240	Seal, air piston
1503	Screw, fan control
2691	Alum. suction cup
2733	Lid fitting, complete with seal ring
3426	Circlip, pin
3624	Pin, air micrometer
3699	Pin, lower trigger
6395	Disc, CC (standard), pk of 4
9050	Tool Kit
12591	Pin, upper trigger
14605	Bushing, needle
14993	Spring, needle bushing
15438	Kit, needle packing
17525	Spring, spacer lock
17897	Spring, needle
23275	Seal, needle
26120	1L Alum. suction cup wo/lid, w/rivets
27813	Spring, air piston
38265	Material filter, R 3/8
45286	Non-drip device for suction cup, 4 pk
50195	Sieve for suction cup, 2 pk
51680	Gasket rings for suction cup, 4 pk
69872	O Ring, fan control
82826	Kit, air piston service set
89771	Control, RH w/O-Ring
91140	QC w/nipple
91157	QC w/filter and nipple
91959	Air piston
92031	Paint pipe, R 3/8
92577	Tool set
93526	Material connection
130393	Seal, air cap ring
130435	Air cap ring only (RP)
130484	Insert w/needle packing kit
130492	Kit, trigger
130534	Ring, air distribution, pk of 3
130534-1	Ring, air distribution, each
130542	Repair Kit, Jet 1000 K
133926	Kit, trigger sleeve
133934	O Ring, fan control, pk of 3
133942	Bushing, air piston
133959	Kit, spring, 3 ea. of #27813 & #17897
133967	Pin, air micrometer, pk of 3
133983	Fitting, air inlet, R ?
133991	Seal, air piston, pk of 3
139188	Kit, fluid control and lock nut
139964	Air micrometer, standard
140574	Knob, fan control w/screw
140582	Seal, fluid tip, pk of 5
183780	Sealing kit

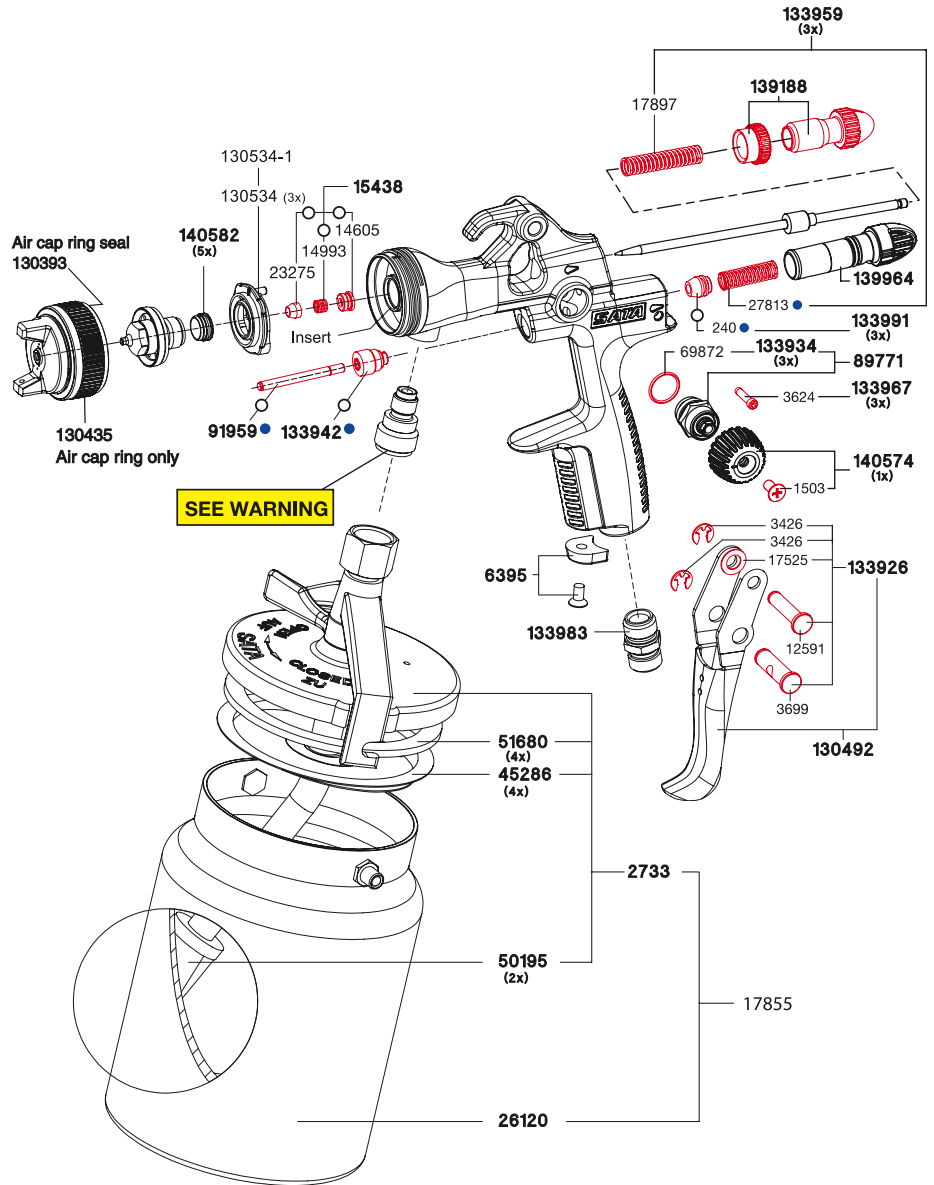

***WARNING**
Do not remove the insert, seal, and fluid inlet. Special tools are required.

CALL SATA repair department for details.

92577 Tool Kit	
901	Universal spanner wrench
3509	Cleaning brush
9647	Internal hex wrench
64543	Allen wrench
43638	Extraction tool

Order No./Desc.
130542
Repair kit
<input type="radio"/> 92759
Air piston service set
<input type="radio"/> 183780
Sealing Kit

Technical modifications and printing errors reserved

Material and air connection SATAjet® 3000 K, 1000 K

Order No./ Desc.
6981 Quick coupling nipple G 1/4 female thread, packing unit:5
13623 SATA quick coupling 100.14 G 1/4 male thread
38265 Strainer for SATA pressure fed spray guns G3/8i - G3/8a. 60 mesh, WA-version
91140 Material coupling G 3/8 a for SATA pressure fed spray guns with plug-in nipple G3/8i
91157 Material coupling with plug-in nipple and material strainer 60 mesh, G3/8i - G3/8a for SATA pressure fed spray guns
92031 Paint pipe for SATA pressure fed spray guns G3/8i - G3/8a version for waterborne material

Spare sieves

Order No./ Desc.
12260 4-pk sieves, 60 mesh for SATA paint strainer
12278 4-pk sieves, 100 mesh for SATA paint strainer
74856 SATA strainer kit, consisting of 4 sieves 200 mesh, 2 strainer holders and 1 screw for SATA paint strainer

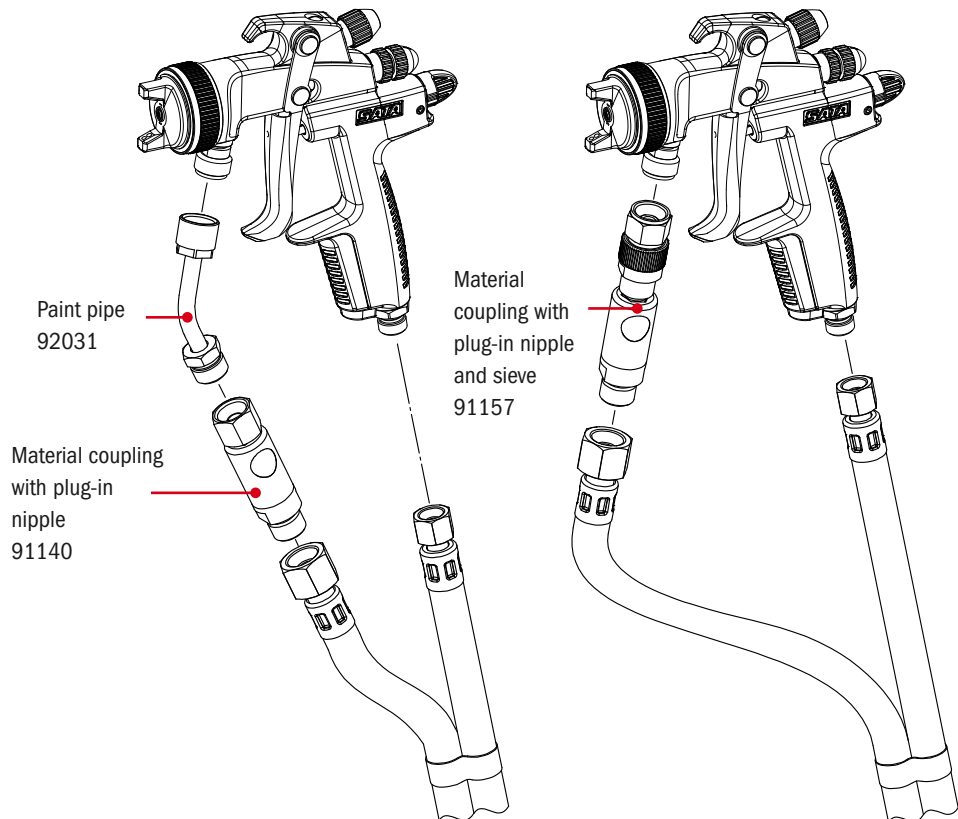
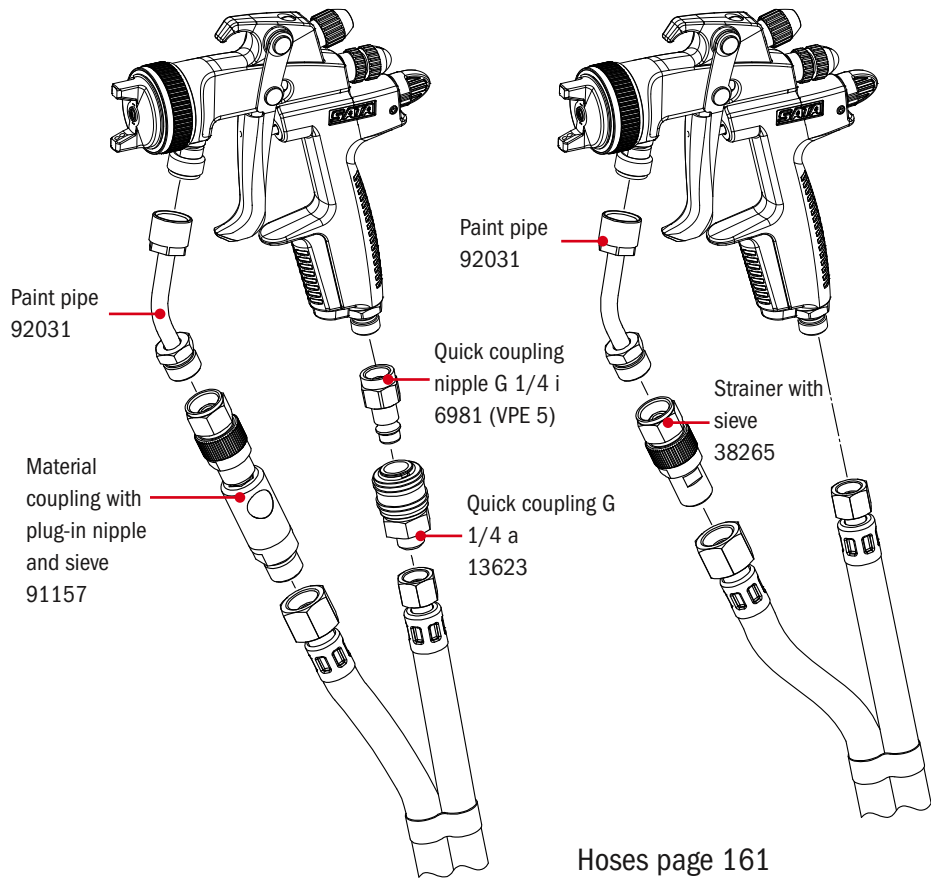

Technical modifications and printing errors reserved

Material and air connection SATAminijet® 1000 K

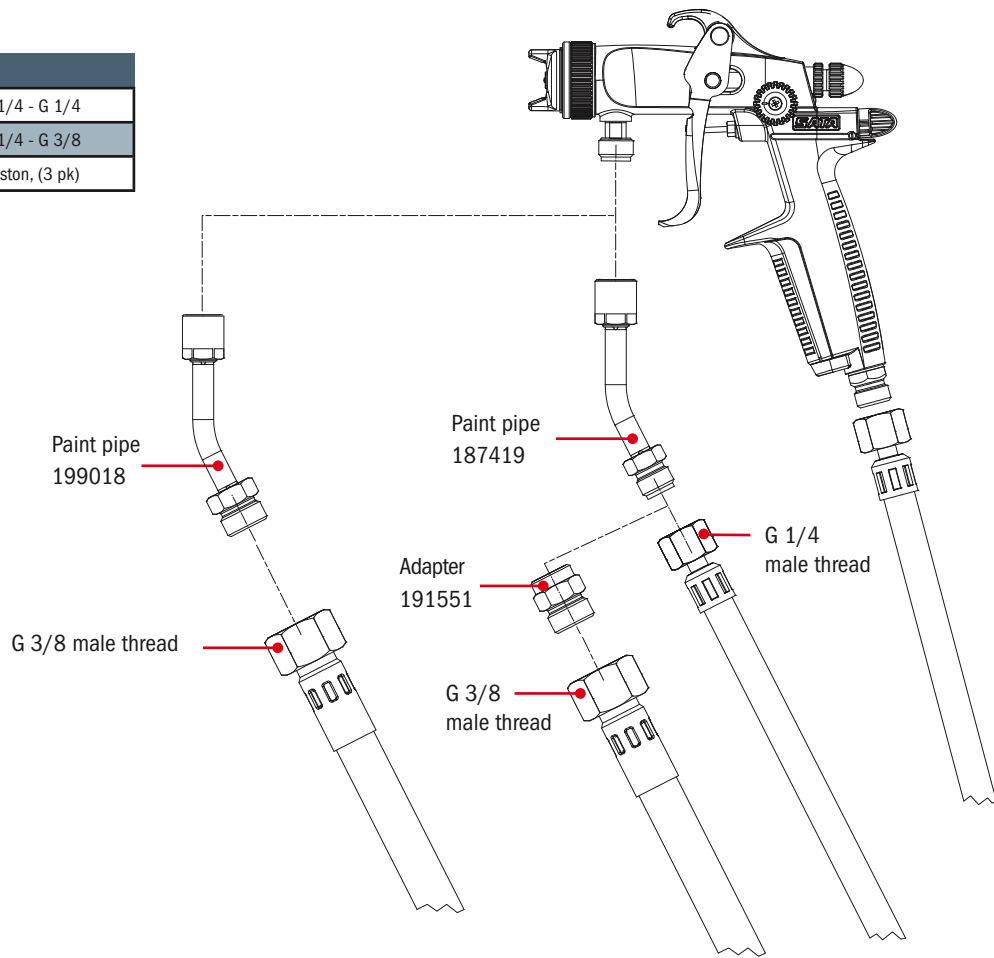

Order No./Desc.	
187419	Paint pipe, G 1/4 - G 1/4
191018	Paint pipe, G 1/4 - G 3/8
191551	Packing, air piston, (3 pk)



Hoses page 161

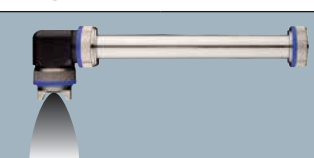

Accessories SATAjet® 3000 K, SATAjet® 1000 B/K,

Extensions SATAjet 1000 K RP

154435	20 cm - Straight Extension SATAjet 1000 K RP 1.5 round/flat fan	
154443	30 cm - Straight Extension SATAjet 1000 K RP 1.5 round/flat fan	
154450	40 cm - Straight Extension SATAjet 1000 K RP 1.5 round/flat fan	
154476	20 cm - 45° Diagonal spray extension SATAjet 1000 K RP 1.6	
154484	30 cm - 45° Diagonal spray extension SATAjet 1000 K RP 1.6	
154492	40 cm - 45° Diagonal spray extension SATAjet 1000 K RP 1.6	
154518	20 cm - 360° Internal mixing extension SATAjet 1000 K RP 1.6	
154526	30 cm - 360° Internal mixing extension SATAjet 1000 K RP 1.6	
154534	40 cm - 360° Internal mixing extension SATAjet 1000 K RP 1.6	
154559	20 cm - 90° Angular head extension SATAjet 1000 K RP 1.6	
154567	30 cm - 90° Angular head extension SATAjet 1000 K RP 1.6	
154575	40 cm - 90° Angular head extension SATAjet 1000 K RP 1.6	



Extensions in other lengths are available upon request

Extensions SATAjet 1000 A RP





164293	20 cm - 45° Diagonal spray extension SATAjet 1000 K RP 1.6	
164301	30 cm - 45° Diagonal spray extension SATAjet 1000 K RP 1.6	
Call	40 cm - 45° Diagonal spray extension SATAjet 1000 K RP 1.6	
164277	20 cm - 360° Internal mixing extension SATAjet 1000 K RP 1.6	
164285	30 cm - 360° Internal mixing extension SATAjet 1000 K RP 1.6	
Call	40 cm - 360° Internal mixing extension SATAjet 1000 K RP 1.6	

Extensions in other lengths are available upon request

Accessories for SATA pressure fed spray guns

92031	Paint pipe for SATA pressure fed spray guns G3/8i - G3/8a version for waterborne materials	
38265	Strainer for SATA pressure fed spray guns G3/8i - G3/8a, 60 mesh, WA version	

Additional accessories for SATA pressure fed spray guns

12260	4-pk sieves, 60 mesh for SATA paint strainer	
12278	4-pk sieves, 100 mesh for SATA paint strainer	
74856	SATA strainer kit, consisting of 4 sieves 200 mesh, 2 strainer holders and 1 screw for SATA paint strainer	
91108	QC nipple	
91140	Material coupling G 3/8 a for SATA pressure fed spray guns with plug-in nipple G3/8i	
91157	Material coupling with plug-in nipple and material strainer 60 mesh, G3/8i - G3/8a for SATA pressure fed spray guns	

Technical modifications and printing errors reserved

Parts nozzle extensions

Components for SATAjet 1000 RP - Straight Nozzle Extension

SATAjet 1000 K Straight Nozzle Extension

Part No.	Description
140582	Seal, fluid tip, pk of 5
154914	Sealing ring

Ext. No.	Length	Pos 10	Pos 20	Pos 30	Pos 40	Pos 50
154435	20cm	154880	139071	139477	154716	154807
154443	30cm	154896	139071	139477	154724	154815
154450	40cm	154906	139071	139477	154732	154450

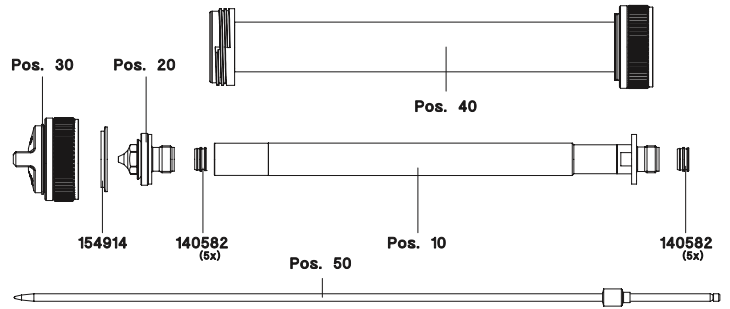

SATAjet 1000 K & A 45° Nozzle Extension

Part No.	Description
43760	Tightening ring
140582	Seal, fluid tip, pk of 5
155226	Flange sleeve

Ext. No.	Length	Pos 10	Pos 20	Pos 30	Pos 40	Pos 50
154476	20cm	155184	24158	24141	24182	155267
154484	30cm	155192	24158	24141	4432	155275
154492	40cm	155200	24158	24141	4531	155283

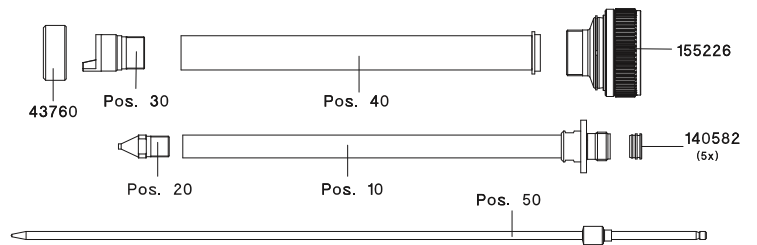

Ext. No.	Length	Pos 10	Pos 20	Pos 30	Pos 40	Pos 50
164293	20cm	155184	24158	24141	24182	46490
164301	30cm	155192	24158	24141	4432	47100
	40cm	155200	24158	24141	4531	47688

SATAjet 1000 K 90° Nozzle Extension

Part No.	Description
30932	O-ring
140582	Seal, fluid tip, pk of 5
154955	Angular head
155099	Fluid tip 3.0

Ext. No.	Length	Pos 10	Pos 20	Pos 30	Pos 40	Pos 50
154559	20cm	155036	139071	139477	154971	155101
154567	30cm	155044	139071	139477	154989	155119
154575	40cm	155051	139071	139477	154997	155127

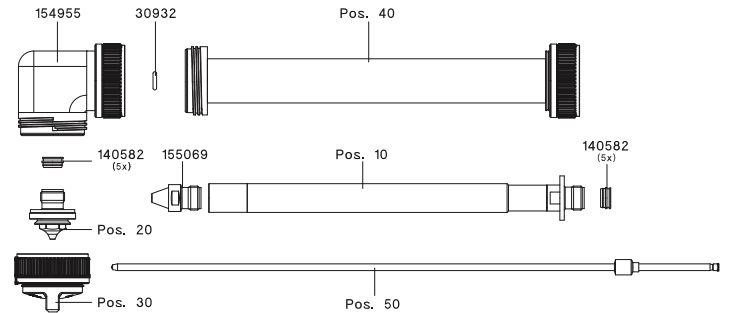

SATAjet 1000 K 360° Nozzle Extension

Part No.	Description
30585	Plate-shaped internal mixing nozzle
30593	Nozzle screw
43760	Tightening ring
140582	Seal, fluid tip, pk of 5
155228	Flange sleeve

Ext. No.	Length	Pos 10	Pos 20	Pos 40	Pos 50
154518	20cm	155184	24158	24182	155267
154526	30cm	155192	24158	4432	155275
154534	40cm	155200	24158	4531	155283

Ext. No.	Length	Pos 10	Pos 20	Pos 40	Pos 50
164277	20cm	155184	24158	24182	46490
164285	30cm	155192	24158	4432	47100
	40cm	155200	24158	4531	47688

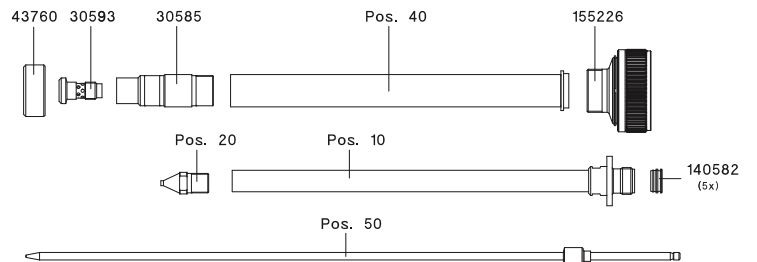

Technical modifications and printing errors reserved

SATAjet® 100 B F RP®/HVLP, SATAjet® 100 B P



SATAjet 100 B F HVLP

Technical Data

Inlet pressure: 2 bar / 29 psi
 Air consumption: 2.0 bar: 350 NI/min / 12.4 cfm @ 36 psi
 Spray distance: 18-23 cm / 5-7 in



Nozzle	1.4	1.7	1.9	2.1
---------------	-----	-----	-----	-----

Standard gun with 0.6 l QCC PVC cup

Order No.	146373	145722	145730	145748
------------------	--------	--------	--------	--------

Standard gun with 0.75 l QCC aluminum cup

Order No.	147447	146175	146183	147454
------------------	--------	--------	--------	--------

Standard gun with 1.0 l aluminum cup

Order No.	146399	146191	146209	147462
------------------	--------	--------	--------	--------

Test Air Cat

157214

Nozzle	1.4	1.7	1.9	2.1
---------------	-----	-----	-----	-----

Nozzle Set

Order No.	146381	145417	145425	145433
------------------	--------	--------	--------	--------

SATAjet 100 B F RP

Technical Data

Inlet pressure: 1.5 - 2.0 bar / 7-29 psi
 Air consumption: 2.0 bar: 290 NI/min / 10.2 cfm @ 29 psi
 Spray distance: 18-23 cm / 5-7 in



Nozzle	1.4	1.6	1.8	2.0
---------------	-----	-----	-----	-----

Standard gun with 0.6 l QCC PVC cup

Order No.	146969	145193	145201	145219
------------------	--------	--------	--------	--------

Standard gun with 0.75 l QCC aluminum cup

Order No.	153023	146134	146142	147421
------------------	--------	--------	--------	--------

Standard gun with 1.0 l aluminum cup

Order No.	153460	146159	146167	147439
------------------	--------	--------	--------	--------

Nozzle	1.4	1.6	1.8	2.0
---------------	-----	-----	-----	-----

Nozzle Set

Order No.	146977	145250	145268	145276
------------------	--------	--------	--------	--------

SATAjet 100 B P

Technical Data

Inlet pressure: 1.5 - 2.0 bar / 29 psi
 Air consumption: 2.0 bar: 245 NI/min / 8.7 cfm @ 29 psi
 Spray distance: 18-23 cm / 5-7 in



Nozzle	P
---------------	---

Standard gun with 0.6 l QCC PVC cup

Order No.	145185
------------------	--------

Standard gun with 0.75 l QCC aluminum cup

Order No.	146217
------------------	--------

Standard gun with 1.0 l aluminum cup

Order No.	147470
------------------	--------

Nozzle	P
---------------	---

Nozzle Set

Order No.	145284
------------------	--------

Technical modifications and printing errors reserved

Spare Parts SATAjet® 100 B

Order No./Desc.

240	Packing, air piston
901	Wrench, universal spanner
1503	Screw, fan control
1826	Non-drip device (4 pk)
3426	Circlip, pin
3509	Brush, large standard
3624	Pin, air micrometer
3699	Pin, lower trigger
3988	Sieve, pk of 20
3988-5	Sieve, pk of 5
6007	Brush, nozzle cleaning, pk of 10
6395	Disc, CC (standard), pk of 4
6585	Insert, aluminum cup
9050	Tool kit
9647	Allen wrench, 4mm
12591	Pin, upper trigger
14605	Bushing, needle packing
14993	Spring, needle packing
15438	Kit, needle packing
17525	Washer, tension spring
17897	Spring, paint needle
23275	Packing, needle
27243	Cup, 0.6L QCC plastic
27375	Spring, needle packing, (12 pk) of #14993
27813	Spring, air piston
43638	Puller, wire air ring
49395	Lid, 0.6L plastic
49437	Cup Lid Drip Ring, 0.6L, (5 pk)
69872	O Ring, fan control
71555	Lid, plastic, (3 pk)
89771	Control spindle, flat/round, w/"O"ring
82826	Kit, air piston service
91959	Piston, air rod
96644	Nipple, QCC aluminum cup
96685	Cup, 1L QCC aluminum
96693	Ring, QCC marking
96719	Adapter, QCC to PPS cup
96875	Seal, inner cup
130393	Seal, air cap ring
130492	Kit, trigger service complete
130542	Repair kit, SATAjet 100 B series
133884	Kit, battery, cover w/gasket
133926	Kit, trigger sleeve
133934	O ring, fan control, (3 pk)
133942	Bushing, air piston
133959	Kit, spring, (3 ea. of #27813 & #17897)

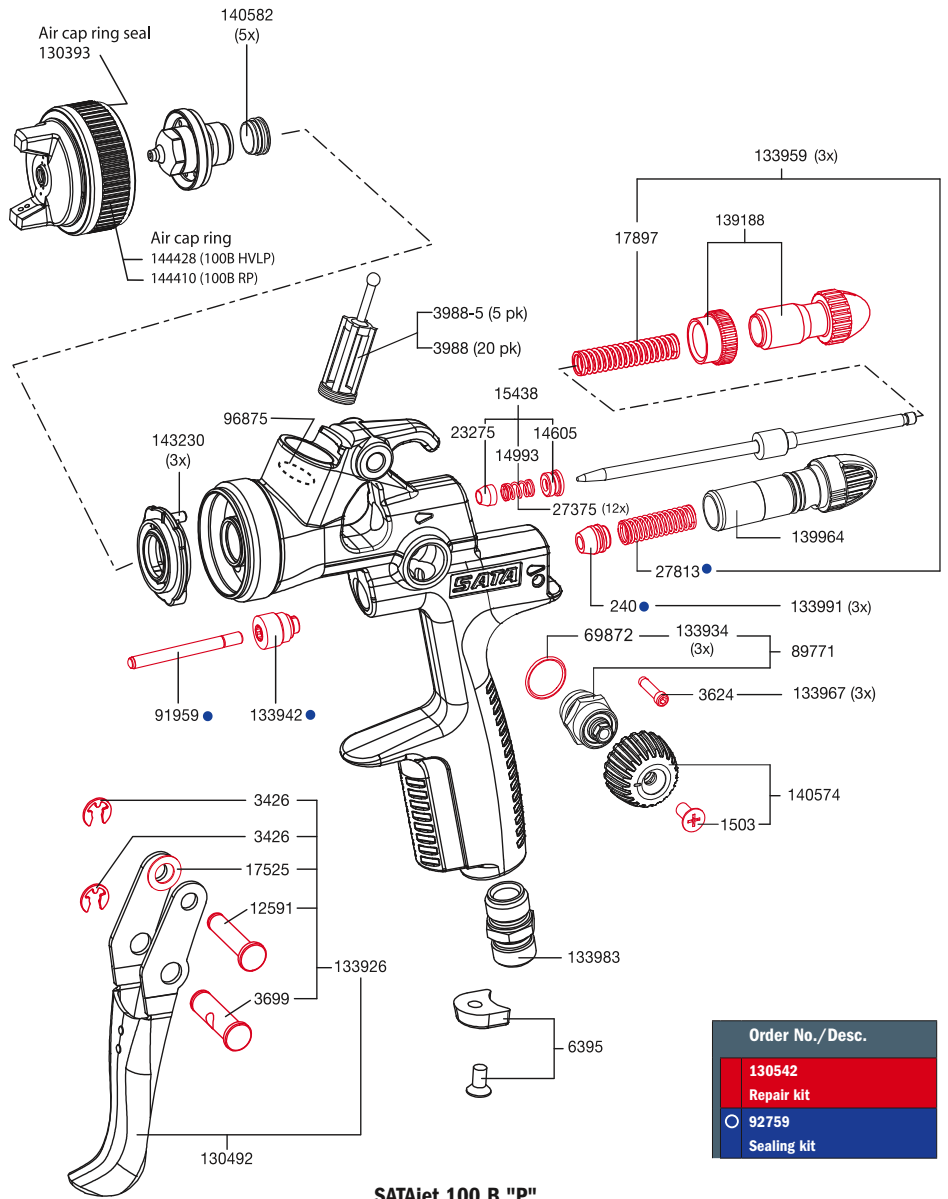

Order No./Desc.

133967	Pin, air micrometer, (3 pk)
133983	Fitting, standard 1/4" air inlet
133991	Packing, air piston, (3 pk)
139188	Kit, fluid control and lock nut
139964	Air micrometer, HVLP & RP only
140574	Knob, fan control w/ screw
140582	Fluid tip seal (5 pk)
143230	Air distribution ring (3 pk)
144410	Air cap ring with seal (RP)
144428	Air cap ring with seal (HVLP)
Only with SATAjet 100 B "P" version:	
25874	O ring 9 x 1.5
78154	Closing cap w O ring seal

SATAjet 100 B "P"

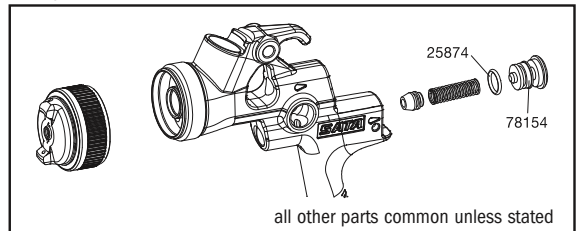

all other parts common unless stated

9050 Tool Kit

901	Universal spanner wrench
3509	Cleaning brush
9647	Allen/Torx wrench
64543	Allen wrench
43638	Extraction tool



Technical modifications and printing errors reserved

SATAjet® 90-2®



SATAjet 90-2 HVLP

SATAjet 90-2 HVLP sealer spray gun This is an incredible sealer gun for all painters. Perfect topcoats can only be achieved over a perfectly smooth surface. This gun allows that ideal foundation, at an incredibly affordable price.

- Perfect sealer application
- Nice-sized, even spray pattern
- Fast working speed
- Increased transfer efficiency compared to high pressure conventional spray guns
- Anodized spray gun body for easy cleaning and durability
- Excellent value for cost sensitive painters

The balanced design results in required comfort and ergonomics, and the gun's surface will work with any solvent or waterborne product. You'll be quite happy with the performance and finishes you'll achieve with the SATAjet 90-2 HVLP - at an affordable price.



Technical Data	Inlet pressure: 29 psi
	Air consumption: 15.0 cfm at 29 psi
	Spray distance: 5 - 7 in
	Finish: Anodized gray

Nozzle	1.3	1.4
---------------	-----	-----

Standard gun with 1.0 L aluminum cup

Order No. STD	126136	126144				
----------------------	--------	--------	--	--	--	--

Nozzle	1.3	1.4
---------------	-----	-----

Nozzle Set

Order No. STD	126102	126110				
----------------------	--------	--------	--	--	--	--

SATAjet 90-2 RP

Nozzle	1.3	1.4
---------------	-----	-----

Nozzle Set

Order No.	123257	123265		
------------------	--------	--------	--	--

Spare Parts SATAjet® 90-2

Order No./Desc.	
109	Air inlet fitting
240	Air piston packing
901	Universal spanner wrench
1503	Fan control screw
3426	Circlip, pin
3509	Standard cleaning brush
3624	Pin, micrometer
3657	Knob, fan control
3699	Pin, lower trigger
3988	Paint sieve, 20 pk
3988-5	Paint sieve, 5 pk
6007	Std. cleaning brush, 10 pk
6213	Trigger Service Set
9050	Tool set, Jet 90-2 HVLP & RP
9647	Allen wrench, 4
12591	Pin, upper trigger
14605	Bushing, needle packing
14993	Packing spring, each
15438	Needle packing service set
17525	Washer, tension spring
17897	Needle spring, each
23275	Needle packing
26518	Fluid control service set
27813	Air piston spring, each
50146	Fluid regulating control
50542	Lock nut, fluid control
53603	Air micrometer
57620	Repair kit, Jet 90-2
64543	Allen wrench, 2
65557	Knob, fan control
69872	Control O ring
82552	Air piston service set
82636	Bushing, air piston
86843	Air piston
89391	Trigger
89771	Fan control
123455	Air ring, 3 pk

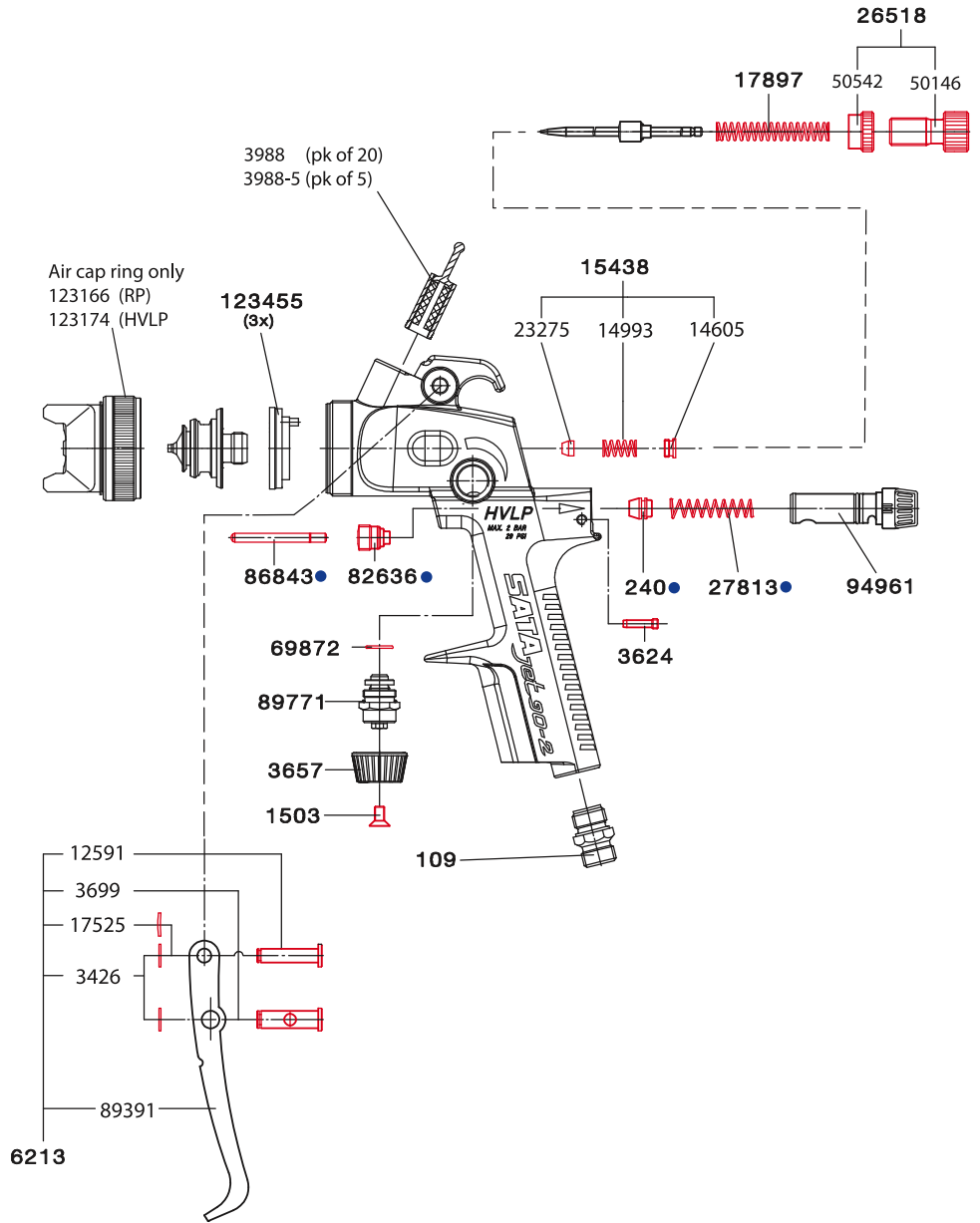

9050 Tool Kit	
901	Universal spanner wrench
3509	Cleaning brush
9647	Allen/Torx wrench
64543	Allen wrench
43638	Extraction tool

Order No./Desc.
57620 Repair kit
82552 Air piston service set

Technical modifications and printing errors reserved

SATAmijet® 3000 B HVLP



SATAmijet 3000 B HVLP

Technical Data	Inlet pressure: 2.0 bar / 29 psi
	Air consumption: 2.0 bar: 115 Nl/min / 4.1 cfm at 29 psi
	Spray distance: 12-15 cm / 5-6 in

Nozzle	0.3	0.5	0.8	1.0	1.1	0.8 SR	1.0 SR	1.2 SR	1.4 SR
---------------	-----	-----	-----	-----	-----	--------	--------	--------	--------

SATAmijet 3000 B HVLP with 0.125 l PVC cup

Order No.	125633	125641	125658	125666	125674	125724	125732	125740	125757
------------------	--------	--------	--------	--------	--------	--------	--------	--------	--------

SATAmijet 3000 B HVLP with 0.150 l aluminum cup

Order No.	125633-15	125641-15	128512	128520	128538	128488	128496	125765	128504
------------------	-----------	-----------	--------	--------	--------	--------	--------	--------	--------

SATAmijet 3000 B HVLP with 0.30 l PVC cup

Order No.						125724-3	125732-3	125740-3	125757-3
------------------	--	--	--	--	--	----------	----------	----------	----------

SATAmijet 3000 BT HVLP - Convertible from gravity to pressure fed, includes cup and 90° adapter

Order No.	125633PT	125641PT	125658PT	125666PT	125674PT	125724PT	125732PT	125740PT	125757PT
------------------	----------	----------	----------	----------	----------	----------	----------	----------	----------

Test Air Cap	126300	126474	126482	126490
---------------------	--------	--------	--------	--------

Nozzle	0.3	0.5	0.8	1.0	1.1	0.8 SR	1.0 SR	1.2 SR	1.4 SR
---------------	-----	-----	-----	-----	-----	--------	--------	--------	--------

Nozzle Set Standard

Order No.	125583	125591	125609	125617	125625	125682	125690	125708	125716
------------------	--------	--------	--------	--------	--------	--------	--------	--------	--------

Special Versions

125773	SATAmijet 3000 HVLP design set with air hose, glass cups, plastic cup, adapters and micrometer - specify nozzle at time of order Specify nozzle size or will be shipped with 1.0 nozzle	
127829	SATAmijet 3000 BT HVLP. Pressure fed conversion of a SATAmijet to allow optimal material flow - specify nozzle at time of order Specify nozzle size or will be shipped with 0.3 nozzle	
670284	SATAmijet 3000 BT HVLP Combo, includes 2L Dan-Am pressure pot and 0.125L PVC cup to convert from pressure fed to gravity fed, dual hose Specify nozzle size or will be shipped with 0.8SR nozzle	

Spray pattern comparison

SATAmijet 3000 B HVLP 1.0 (at 2.0 bar / 29 psi) for standard applications	SATAmijet 3000 B HVLP 1.0 SR (at 2.0 bar / 29 psi) for spot repair applications
	<ul style="list-style-type: none"> · Lowers risk of creating bright edges · Allows painter to apply thin layers of paint

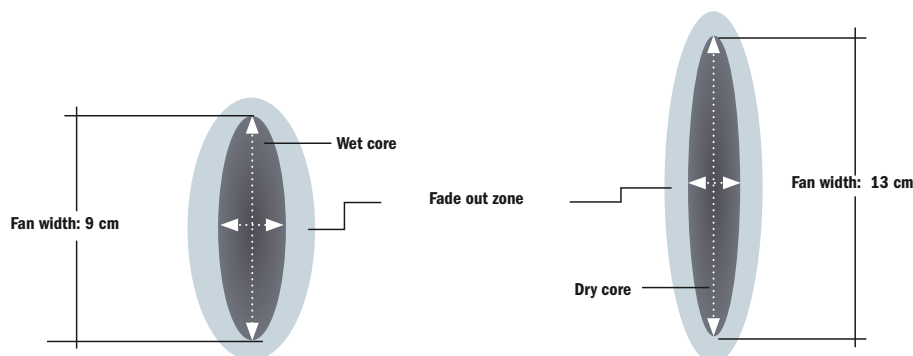

Technical modifications and printing errors reserved

Spare Parts SATAmijet® 3000 B HVLP

Order No./Desc.	
901	Universal spanner wrench
3509	Standard cleaning brush
6007	Standard brush, pk of 10
6395	ColorCode discs, pk of 4
15925	Spanner wrench, small
16295	Glass cup w/plug-in lid
22566	Pin, upper trigger
26583	Circlip
35600	Cup Seal
44644	Lock nut
44669	Spring, needle
44677	Pin, lower trigger
44735	Screw, fan control
44818	Spring, air piston
44826	Packing, air piston
44834	Air piston
44842	Bushing, needle packing
44859	Packing, needle
50658	Packing set, minijet
53033	Set of 5 glass plug-in cups
58164	Set of 5 glass cups w/lid
62810	Piston packing
64022	.150 L cup lid, pk of 3
64022-10	.150 L cup lid, pk of 10
64972	Air micrometer pin
68809	Spring, needle packing
74351	Gasket, air hose
79905	Needle packing service set
95448	.125 L lid w/drip proof vent
95489	Anti-drip device, pk of 4
124164	Knob, fan control
124271	Air distribution ring
124768	Air cap ring w/seal
125112	Snap ring (air cap ring)
125146	Knob, fluid control
125187	Air micrometer
125344	Fan control, O Ring, small
125351	Fan control
125377	Bushing, air piston
125443	.125 L QCC plastic cup w/lid
125492	Trigger
125856	Tool set
125948	.150 L QCC alum. cup w/lid
125955	Adapter, plug-in cup (QCC)
125963	Quick color change set 5 cups, 2 funnels, adapter
126037	Washer, tension spring
126276	Trigger service set

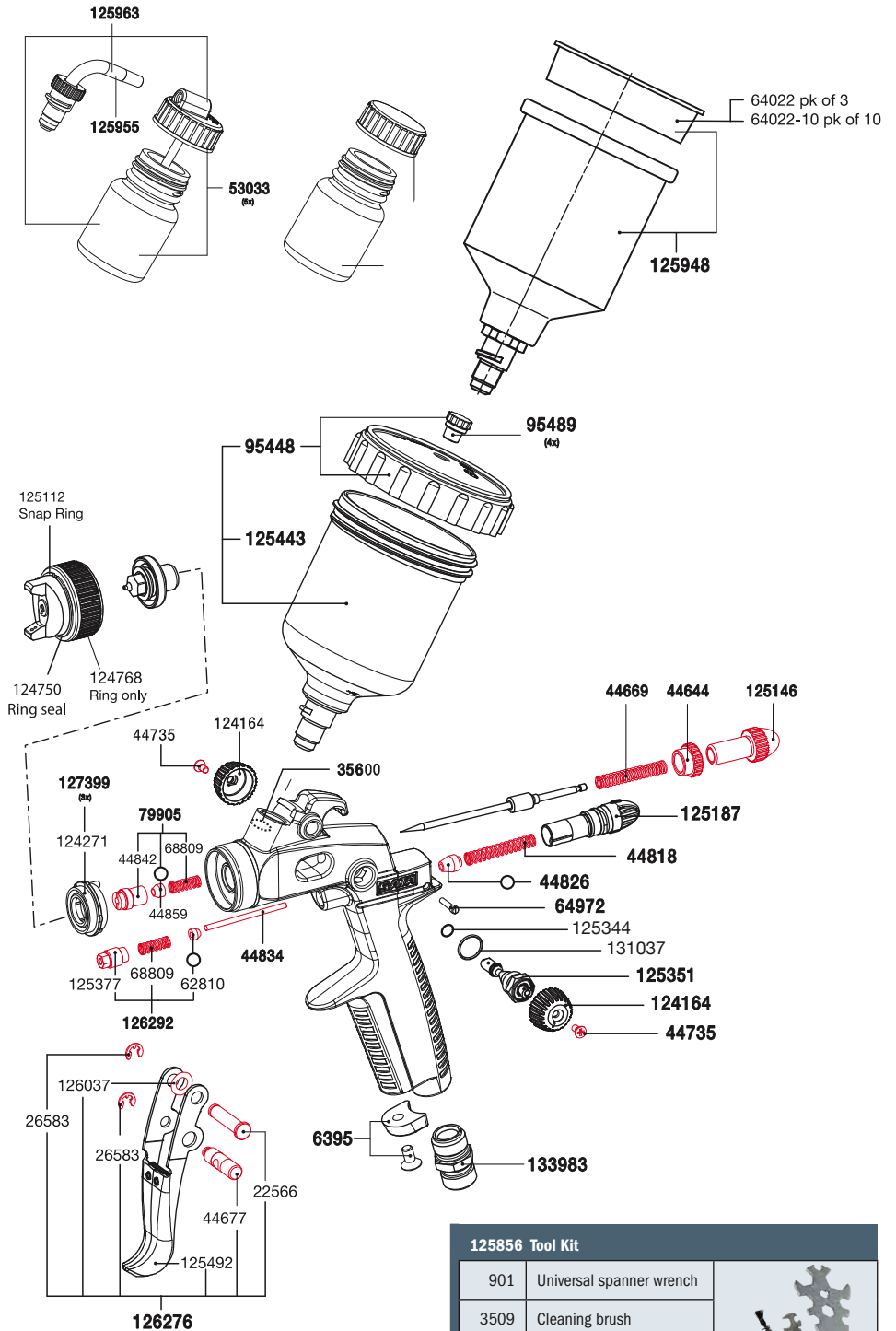

Order No./Desc.	
126284	Repair kit, minijet 4
126292	Air piston service set
127399	Air distribution ring, pk of 3
129346	QCC adapter for PPS cup
131037	Fan control, O Ring, large
133983	Air inlet fitting, 1/4 BSP

125856 Tool Kit	
901	Universal spanner wrench
3509	Cleaning brush
15925	Wrench, multi
43638	Extraction tool

Order No./Desc.	
<input checked="" type="checkbox"/>	126284 Repair kit
<input type="checkbox"/>	50658 Sealing kit

Technical modifications and printing errors reserved

SATaminijet® 1000 K RP®/HVL



SATaminijet 1000 K RP



Technical Data	Inlet pressure: 36 psi
	Air consumption: 7 cfm @ 36 psi
	Spray distance: 6 - 8 in
	Weight: 10 oz.
	Material connection: G 1/4 male thread

Nozzle	0.3	0.5	0.8	1.0	1.2	1.4
---------------	-----	-----	-----	-----	-----	-----

Spray gun							
Art. No.	187450	187468	187476	187484	187492	197152	

Nozzle set							
Art. No.	187625	187633	187641	187658	187666	197160	

SATaminijet 1000 K HVL



Technical Data	Inlet pressure: 29 psi
	Air consumption: 4.2 cfm @ 29 psi
	Spray distance: 4 - 6 in
	Material connection: G 1/4 male thread

Nozzle	0.3	0.5	0.8	1.0	1.2
---------------	-----	-----	-----	-----	-----

Spray gun					
Art. No.	190280	190298	190306	190314	190322

Nozzle set					
Art. No.	190348	190355	190363	190371	190389

Accessories		
187419	Paint pipe, cpl. G1/4 - G1/4	
199018	Paint pipe, cpl. G1/4 - G3/8	
187690	SATAmaterial filter 60 msh, G 1/4	
191551	Adapter, G 1/4 female and G 3/8 male material connection	

Spare Parts SATAminijet® 1000 K

Order No./Desc.	
6395	ColorCode discs, pk of 4
22566	Pin, upper trigger
26583	Circlip
44644	Lock nut
44669	Spring, needle
44677	Pin, lower trigger
44735	Screw, fan control
44818	Spring, air piston
44826	Packing, air piston
44834	Air piston
44842	Bushing, needle packing
44859	Packing, needle
50658	Packing set, minijet
62810	Piston packing
68809	Spring, needle packing
79905	Needle packing service set
124164	Knob, fan control
125112	Snap ring (air cap ring)
125146	Knob, fluid control
125187	Air micrometer
125377	Bushing, air piston
125492	Trigger
125856	Tool set
126037	Washer, tension spring
126276	Trigger service set
187427	Fan control
187435	Air distribution ring, pack of 3

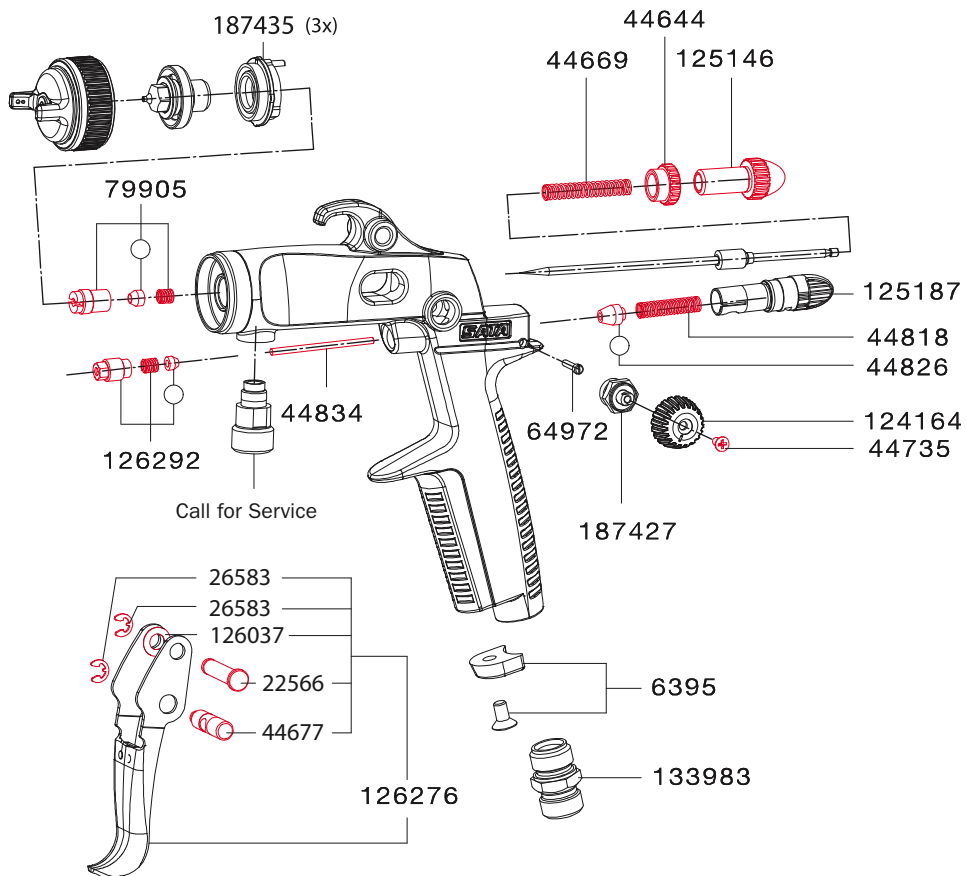

125856 Tool Kit	
901	Universal spanner wrench
3509	Cleaning brush
15925	Wrench, multi
43638	Extraction tool



Art. No./Descr.	Euro
126284	Repair kit
○ 50658	Packing Set

Technical modifications and printing errors reserved

SATAmijet® 1000 H RP®/HVL



SATAmijet 1000 H RP without cup

Technical Data	Inlet pressure: 36 bar
	Air consumption at 7 cfm @ 36 psi
	Spray distance: 6.5 - 8.5 in.
	Weight: 10.1 oz.

Nozzle 1,4



Spray gun without cup

Art. No.	187682	
-----------------	--------	--

Nozzle set

Art. No.	187674	
-----------------	--------	--

SATAmijet 1000 H HVL without cup

Technical Data	Inlet pressure: 29 psi
	Air consumption at 4.1 cfm @ 29 psi
	Spray distance: 4 - 6 in.
	Material connection: G 1/4 male thread

Nozzle 1,4





Spray gun without cup

Art. No.	191502	
-----------------	--------	--

Nozzle set

Art. No.	191494	
-----------------	--------	--

Accessories for SATA pressure fed spray guns

188318	RPS Adapter No. 17 with QCC Connection thread G 1/4 To use for RPS siphon cup.	
188482	RPS Siphon Kit, pins, suction hose, sieve, (for 0.3L cup),pack of 25	
188516	RPS Siphon Kit, pins, suction hose, sieve, (for 0.3L cup), pack of 50	
188490	RPS Siphon Kit, pins, suction hose, sieve, (for 0.6L cup), pack of 25	
188524	RPS Siphon Kit, pins, suction hose, sieve, (for 0.6L cup), pack of 50	
188508	RPS Siphon Kit, pins, suction hose, sieve, (for 0.9L cup), pack of 25	
188532	RPS Siphon Kit, pins, suction hose, sieve, (for 0.9L cup), pack of 50	

Spare Parts SATAminijet® 1000 H

Order No./Desc.	
6395	ColorCode discs, pk of 4
22566	Pin, upper trigger
26583	Circlip
44644	Lock nut
44669	Spring, needle
44677	Pin, lower trigger
44735	Screw, fan control
44818	Spring, air piston
44826	Packing, air piston
44834	Air piston
44842	Bushing, needle packing
44859	Packing, needle
50658	Packing set, minijet
62810	Piston packing
68809	Spring, needle packing
79905	Needle packing service set
124164	Knob, fan control
125112	Snap ring (air cap ring)
125146	Knob, fluid control
125187	Air micrometer
125377	Bushing, air piston
125492	Trigger
125856	Tool set
126037	Washer, tension spring
126276	Trigger service set
187427	Fan control
187435	Air distribution ring, pack of 3

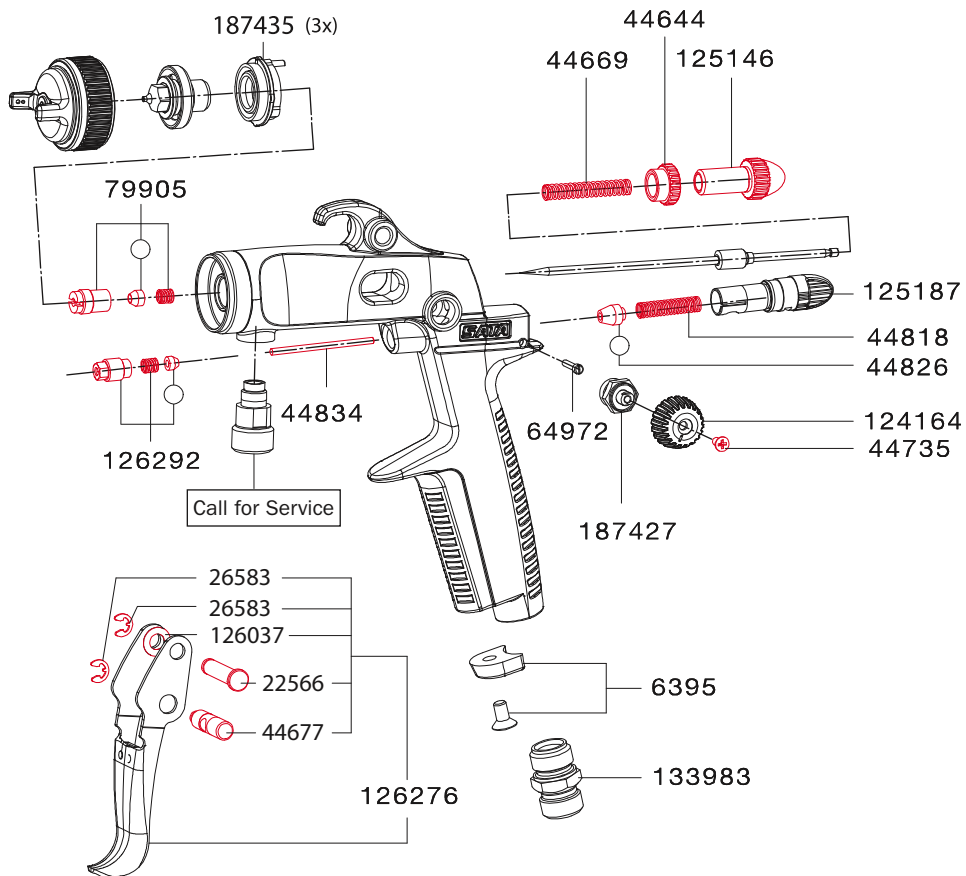

Technical modifications and printing errors reserved

125856 Tool Kit	
901	Universal spanner wrench
3509	Cleaning brush
15925	Wrench, multi
43638	Extraction tool



Art. No./Descr.	Euro
126284	
Repair kit	
○ 50658	
Packing Set	



SATAjet® 20 B

SATAjet 20 B

Conventional Gravity or Siphon Design Gun

Use for hobbies, silk screening, lettering, graphic arts, woodworking or unique design.

An endless list of possibilities for any kind of design work make the SATAjet® 20 B a great choice. This round spray design gun is perfect for vehicle murals, graphic design, calligraphy, airbrushing and many hobbies. Five nozzle sizes from 0.2 to 1.0 add to its versatility. Two separate air inlets may be interchanged without any tools – in the handle or at the backside of the gun. That means it can be handled like a typical spray gun or like an airbrush. The unique design of the SATAjet 20 B allows it to be used by left- or right-handed artists. The gravity cup is easily removed and an adapter switches it to a siphon gun with plug-in cups. These plug-in cups allow quick and easy changing of one color to the next.

The SATAjet 20 B is an excellent choice for a glazing spray gun for the wood industry.

With a controlled application, the material savings and wiping time are significantly reduced.

Nozzle sets with stainless steel needle and fluid tip are standard making them compatible for waterborne. The SATAjet 20 B has self-adjusting Teflon seals and the gun body is finished in durable nickel plating.

Lightweight at only 6.3 oz and low air consumption at 1.4 cfm @ 15 psi makes it ideal for continuous work load. Additionally it can be converted to a pressure fed spray gun for continuous work (*call for setup*).

The most common nozzle size for applying glaze and wiping is 0.5. For pinpoint glazing and no wiping use a 0.2 nozzle.

Nozzle sets with stainless steel needle and fluid tip are standard making them compatible for waterborne. The SATAjet 20 B has self-adjusting Teflon seals and the gun body is finished in attractive nickel plating.



Technical Data

Inlet pressure: 15 psi

Air consumption: 1.5 bar: 1.4 cfm at 15 psi

Spray distance: variable

Nozzle	0.2	0.2 F*	0.35	0.5	0.8	1.0
--------	-----	--------	------	-----	-----	-----

Spray gun with 65 ccm plastic cup

Order No.	65078	189035	65581	65649	66316	69229
-----------	-------	--------	-------	-------	-------	-------

Spray gun with 1 plug-in cap and 4 blind cups, including adapter

Order No.	86181	call	86199	86207	86215	86223
-----------	-------	------	-------	-------	-------	-------

Nozzle	0.2	0.2 F*	0.35	0.5	0.8	1.0
--------	-----	--------	------	-----	-----	-----

Nozzle Set

Order No.	60459	189043	60640	61200	61341	61523
-----------	-------	--------	-------	-------	-------	-------





*F = Fineline

SATA jet 20 B design set

90381	SATAjet 20 B design set:	
	<ul style="list-style-type: none"> • SATAjet 20 B spray gun • 1) 0.5 nozzle • 1) 0.025 l glass plug-in cup • 1) air micrometer w/ gauge • 1) funnel/sieve • 1) 6 ft PVC hose 	<ul style="list-style-type: none"> • 1) 0.2 nozzle (Specify nozzle size or will ship with 0.2) • 4) 0.025 l glass cup w/ blind lid • 1) adapter • 1) packing set • 1) cleaning set • 1) gun holder



Accessories for SATA pressure fed spray guns

69328	Gun holder, gravity or siphon cup		
53033	Plug-in cups, pack of 5		
58164	Plain cups, pack of 5		
60350	Plug-in cup adapter & set of 5 plug-in cups with funnel		
125955	Plug-in cup adapter		

Technical modifications and printing errors reserved

Spare Parts SATAjet® 20 B

Order No./Desc.	
3509	Cleaning brush
6007	Standard cleaning brush, pk of 10
9860	Air micrometer without gauge
9878	Mini water separator
15669	65cc plastic gravity cup
15909	65cc cup lid
15925	Spanner wrench
16295	Plug-in cup, complete
32987	Air hose, PVC, w/QC nipple
22566	Pin, upper trigger
26583	Circlip
44677	Pin, lower trigger
44818	Spring, air piston
44826	Packing, air piston
44834	Air piston
50807	Air piston service set
52282	Bushing, air piston
52373	QC nipple
53033	Plug-in cup, pk of 5
54353	Air hose, PVC, 2m, w/ fittings
55749	Trigger
58164	Glass cup, pk of 5
62042	Spray gun handle
62083	Air tube
62398	Nozzle spindle, Dekor 2000
62729	End screw
62802	Compression bushing
62810	Needle packing
62851	Needle bushing
62869	Knob, fluid control
64758	O ring, 8x1
66928	Air inlet fitting
68809	Spring, needle packing
68817	Spring, needle
69344	Needle packing service set
69427	Packing set, SATAjet 20 B
70326	Allen wrench
74351	Gasket, air hose
79913	Trigger service set
91165	Repair kit, SATAjet 20 B
125955	Plug-in cup connection with QCC
125963	Plug-in cup set, connection adapter, 5 glass cups 25cm, 1 plug-in lid, 4 blind lids

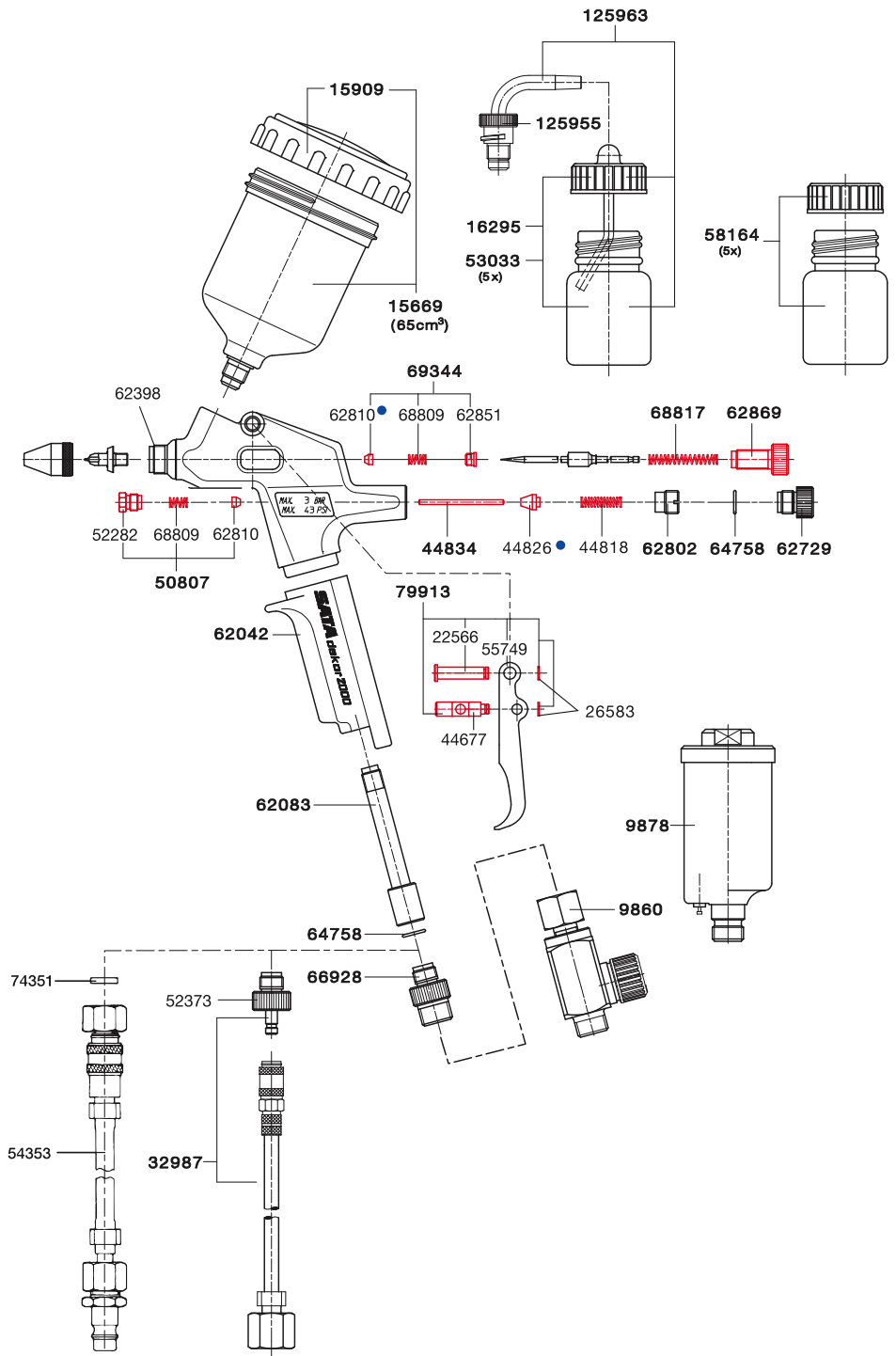

Technical modifications and printing errors reserved

125856 Tool Kit	
3509	Cleaning brush
15925	Wrench, multi
70326	Hex screw driver



Order No./Desc.
91165
Repair kit
<input type="radio"/> 69427
Sealing set

SATAgraph™ 1/2/3

1 - The Starter Model

Technical Data	Inlet pressure: variable
	Air consumption: 0.4 cfm at 14 psi
	Spray distance: variable



Nozzle	0.25	0.45
---------------	------	------

SATAgraph 1 - with 2.5 ml gravity cup, no air hose

Order No.	134544	136069
------------------	--------	--------

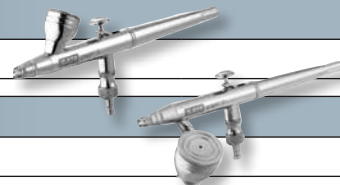

SATAgraph 1 - with 5.0 ml siphon cup, no air hose

Order No.	139568	141408
------------------	--------	--------

Nozzle	0.25	0.45
---------------	------	------

Nozzle Set

Order No.	134619	134635
------------------	--------	--------

SATAgraph 2 - The Universal Airbrush

Technical Data	Inlet pressure: variable
	Air consumption: 10 NI/min / 0.4 cfm at 29 psi
	Spray distance: variable



Nozzle	0.20	0.25
---------------	------	------

SATAgraph 2 with 4.0 ml gravity cup, 15.0 ml siphon cup, no air hose

Order No.	135079	134536
------------------	--------	--------



SATAgraph 2 with 4.0 ml gravity cup, 15.0 ml siphon cup, & 3 m PVC air hose

Order No.	123430	5082
------------------	--------	------

Nozzle	0.20	0.25
---------------	------	------

Nozzle Set

Order No.	123448	31476
------------------	--------	-------

SATAgraph 3 - Premium Airbrush for Professionals

Technical Data	Inlet pressure: variable
	Air consumption: 10 NI/min / 0.4 cfm at 36.3 psi
	Spray distance: variable



Nozzle	0.15	0.25	0.45	0.65
---------------	------	------	------	------

SATAgraph 3 - with 2.5 ml gravity cup, no air hose

Order No.	136077	134569	136085	-
------------------	--------	--------	--------	---



SATAgraph 3 - with 5.0 ml siphon cup, no air hose

Order No.	-	134585	136093	136101
------------------	---	--------	--------	--------

Nozzle	0.15	0.25	0.45	0.65
---------------	------	------	------	------

Nozzle Set

Order No.	134643	134650	134668	134676
------------------	--------	--------	--------	--------

Technical modifications and printing errors reserved

Spare Parts SATAgraph™ 1/2/3

Order No./Desc.
SATAgraph 1
32615 coupling nipple, Pk of 3
134767 2.5 ml gravity flow cup w/ lid
134775 5.0 ml gravity flow cup w/ lid
134783 5.0 ml siphon cup w/ lid
134809 Trigger
134825 Grip end piece
138909 O-ring kit for paint nozzle (5-pieces)
142638 O-ring kit for gravity flow cup (5-pieces)

Order No./Desc.
SATAgraph 2
31781 4.0 ml gravity flow cup w/ 3 plastic lids
32029 Plastic lids for 4.0 ml gravity flow cup, pk of 3
32615 pk of 3 coupling nipples
33001 Grip / end piece
33019 15 ml glass cup w/ lid and suction pipe
33092 15 ml glass cups, 5 closing lids and 1 lid with suction pipe, pk of 5
35964 Needle cap
36020 Trigger
138909 O-ring kit for paint nozzle (5-pieces)

Order No./Desc.
SATAgraph 3
32615 pk of 3 coupling nipples
134767 2.5 ml gravity flow cup w/ lid
134775 5.0 ml gravity flow cup w/ lid
134783 5.0 ml siphon cup w/ lid
134817 Needle cap
134833 Grip end piece, cpl.
134957 Trigger
138909 O-ring kit for paint nozzle (5-pieces)
142638 O-ring kit for gravity flow cups (5-pieces)

SATAgraph 1

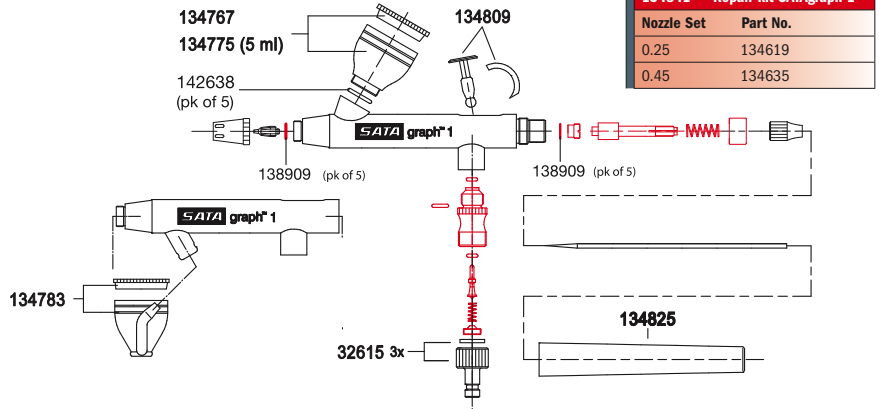

SATAgraph 2

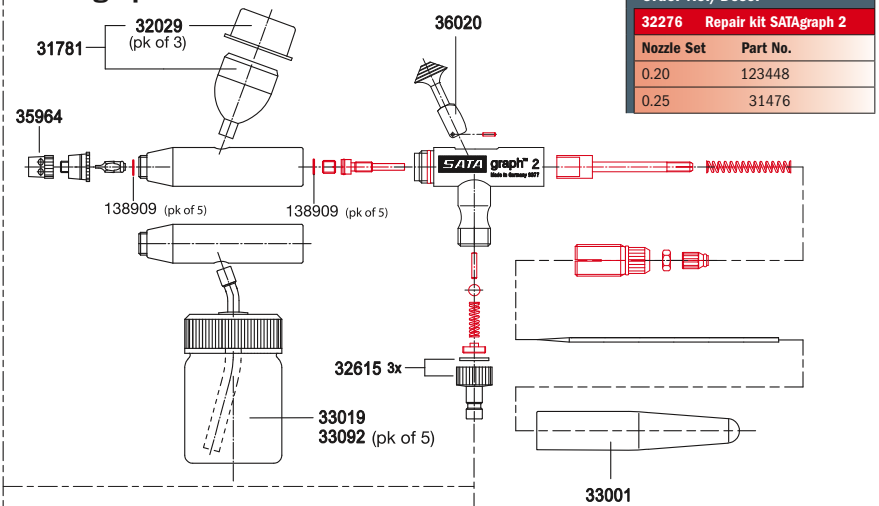

SATAgraph 3

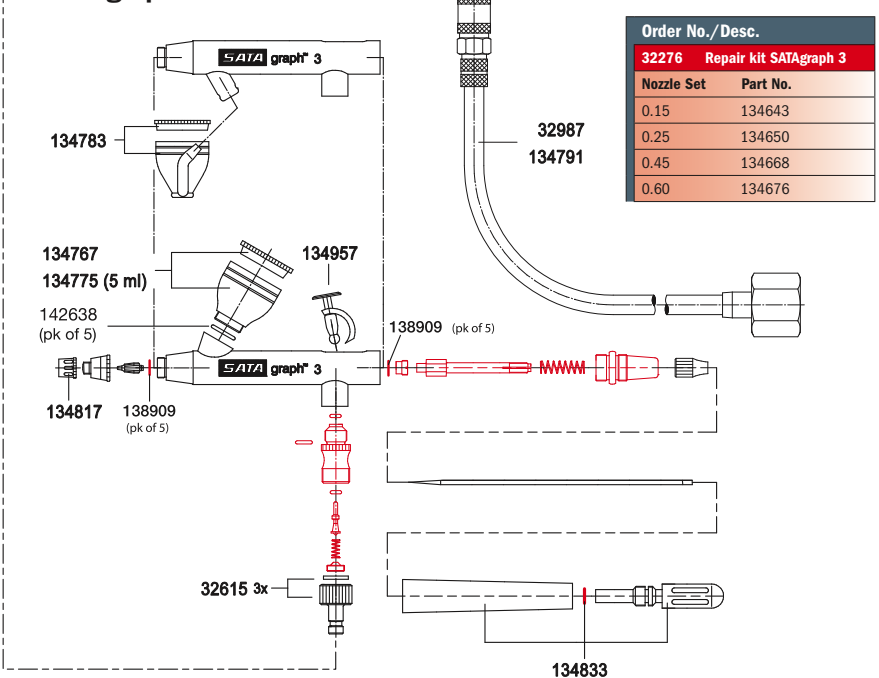

Technical modifications and printing errors reserved

SATAgaph™ 4

SATAgaph 4 B - Gravity Feed

Technical Data

Inlet pressure: variable
 Air consumption: 10 NI/min / 0.4 cfm at 14.5 psi
 Spray distance: variable



Nozzle 0.40

SATAgaph 4 B with 2.5 ml gravity cup, no air hose

Order No. S004B

Needle 0.40

Order No. S005



SATAgaph 4 S - Side Feed

Technical Data

Inlet pressure: variable
 Air consumption: 10 NI/min / 0.4 cfm at 14.5 psi
 Spray distance: variable



Nozzle 0.40

SATAgaph 4 S with 2.5 ml side feed cup, no air hose

Order No. S004S

Needle 0.40

Order No. S005



SATAgaph 4 H - Siphon Feed

Technical Data

Inlet pressure: variable
 Air consumption: 10 NI/min / 0.4 cfm at 14.5 psi
 Spray distance: variable



Nozzle 0.40

SATAgaph 4 S with 2.5 ml siphon cup, no air hose

Order No. S004H

Needle 0.40

Order No. S005



SATAgaph 4 B, H, K

Nozzle 0.40

SATAgaph 4 HBS three gun kit

Order No. S004HBS

Needle 0.40

Order No. S005



Technical modifications and printing errors reserved

Spare Parts SATAgaph™ 4 B/S/H

Order No./Desc.	
S001	Airbrush needle, 0.40
S002	Nozzle tip (fluid tip)
S003	Nozzle cap (inner air cap)
S004	Nozzle cap shield (outer aircap nozzle shield reversible)
S005	Needle/nozzle refurbish kit (includes 001, 002, 003, 004)
S006	Nozzle base
S007	O-ring, nozzle base
S008	Nozzle base wrench
S009	Air valve chamber
S010	Trigger valve stem
S011	Trigger valve spring
S012	Air valve seal / o-ring
S013	Air valve screw
S014	Complete air valve assembly (includes 009, 010, 011, 012, 013)
S015	Inner seal screw and O-ring (gravity and side cup models)
S016	Airbrush trigger
S017	Needle alignment tube and lever assembly
S018	Needle tube spring
S019	Spring tension adjustment knob
S020	Needle locking nut
S021	Needle alignment and adjustment assembly (includes 017, 018, 019, 020)
S022	Bottom (siphon) feed airbrush body
S023	Gravity feed airbrush body
S024	Side feed airbrush body
S025	O-ring, airbrush handle
S026	Trigger stop set handle, red
S027	Trigger stop set screw
S028	Trigger stop set handle and screw (includes 026, 027)
S029	Protective nozzle cover
S030	Siphon lid, metal, fits 3/4 oz. glass cup
S031	3/4 oz. glass cup w/blank storage lid for (S)
S032	3/4 oz. glass cup w/siphon lid for (S)
S033	1/4 oz. color cup (siphon cup-metal)
S034	Side feed metal color cup
S035	Side feed inlet plug, red
S036	Lid, metal, for side (S) and gravity (B) feed color cup
S037	Lid, metal side feed lid for 1 oz. glass cup
S038	1 oz. glass cup w/blank metal storage lid
S039	1 oz. glass cup with metal side feed lid
S040	6 foot braided air hose 1/8 inch X 1/4"
S041	10 foot braided air hose 1/8" X 1/4"
S042	6 foot braided air hose w/ moisture trap
S043	10 foot braided air hose w/ moisture trap
S044	In-line moisture trap
S045	8 foot quick dis-connect braided air hose
S046	Quick disconnect plug/fitting, female
S047	Siphon lid, plastic, fits 3/4 oz. glass cup
S048	3/4 oz. glass cup w/siphon lid for (S)
S049	Pvc lid for 1/4 oz metal siphon color cup
S050	Quick dis-connect air coupler, male
S051	PVC color cup lid Gravity feed (B) and Side feed (S).
S004B	SATAgaph 4 B Gravity feed airbrush
S004S	SATAgaph 4 S Side-feed airbrush
S004H	SATAgaph 4 H Bottom-feed siphon airbrush

SATAgaph 4 B

Gravity cup
S004B

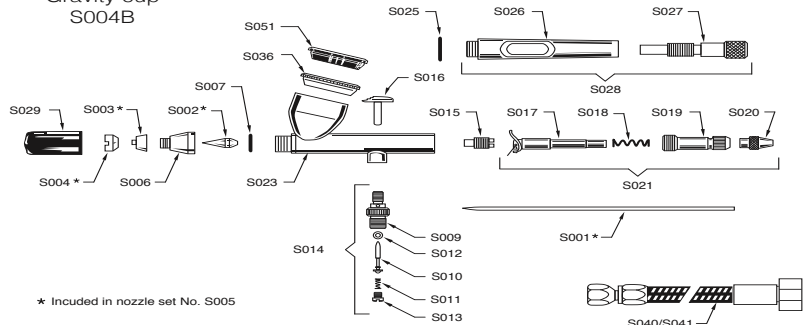

* Included in nozzle set No. S005

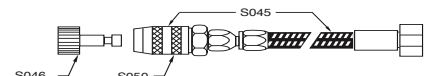
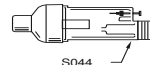
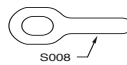

Rev 120823.2

SATAgaph 4 S

w/side mount cup
S004S

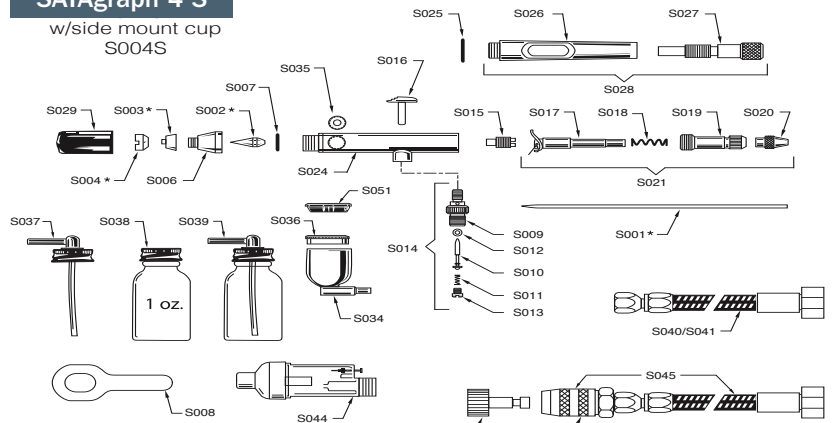

* Included nozzle set No. S005

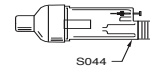

Rev 120823.2

SATAgaph 4 H

w/siphon cup
S004H

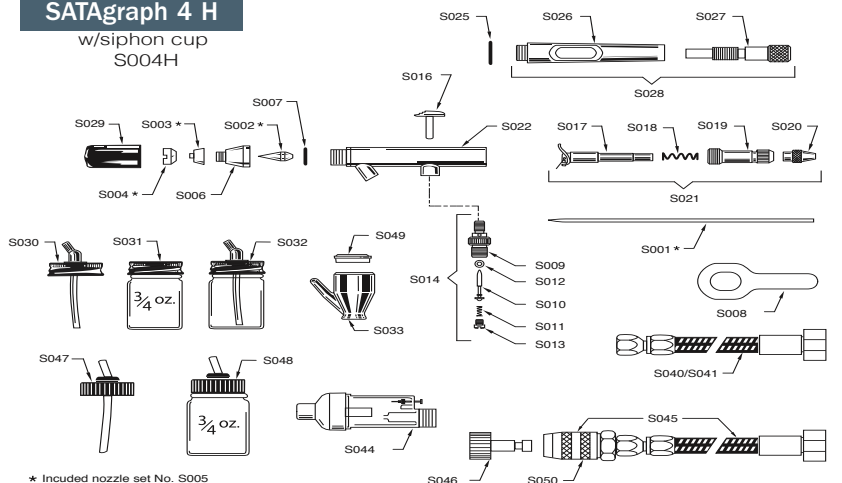

* Included nozzle set No. S005

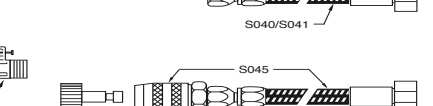
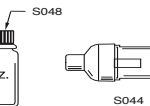
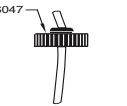

Rev 120823.1

Technical modifications and printing errors reserved

Intermediate cleaning with SATA cleanRCS



1 Clean and rinse material passage and air cap



2 Blow dry spray gun and material passage

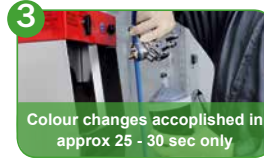

3 Colour changes accomplished in approx 25 - 30 sec only

Cleaning with gun washing machine SATA multi clean 2

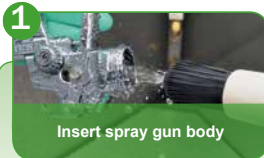

1 Insert spray gun body



2 Connect air connection to air inlet

Please ensure that the spray gun is always placed in the correct position inside the washing chamber of self-contained washing machines. **Make sure that no cleaning agent penetrated the air passages of the spray gun.**

Important Note

It is **essential** to observe the **pH value** of your cleaning agent!

The pH value should be ranging between 6 - 8!

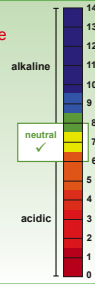

Disassembly of nozzle set

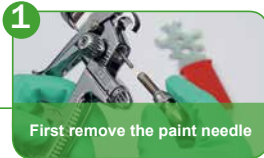

1 First remove the paint needle

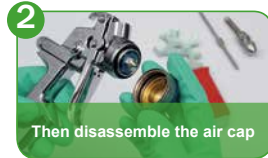

2 Then disassemble the air cap

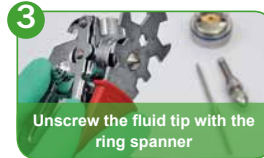

3 Unscrew the fluid tip with the ring spanner

Cleaning and drying of the spray gun...

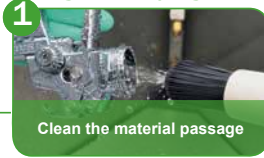

1 Clean the material passage

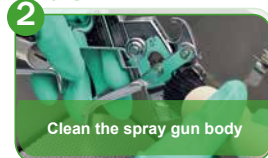

2 Clean the spray gun body

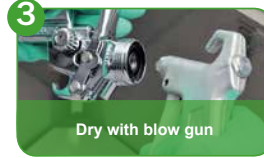

3 Dry with blow gun

... and the nozzle set



1



2



3



4



5



6

Assembly and Maintenance

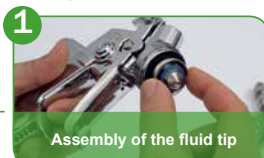

1 Assembly of the fluid tip

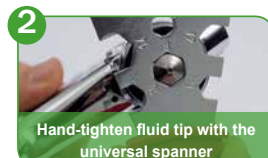

2 Hand-tighten fluid tip with the universal spanner



3 Assembly of the air cap - air cap marking must be legible



4 Grease paint needle around the needle packing area



5 Insert paint needle

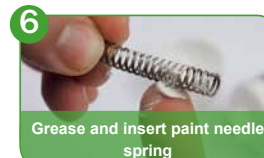

6 Grease and insert paint needle spring

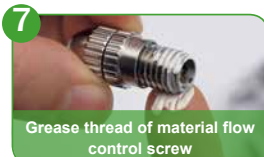

7 Grease thread of material flow control screw

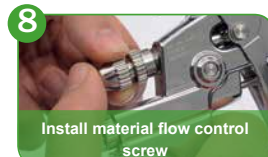

8 Install material flow control screw



9 Grease visible part of air piston rod

Cleaning Accessories



Order No. 158840

5 cleaning brushes, large for cleaning the outside of the gun body



Order No. 6007

10 cleaning brushes, medium size for fluid tip and material passages of gun



Order No. 9209

10 double-sided cleaning brushes for cleaning air caps and fluid tips



Order No. 62174

12 nozzle cleaning needles for cleaning front apertures of air cap and fluid tip



Order No. 48173

High performance grease, 100 ml, silicone and acid free for all moving parts of the gun



Order No. 64030

Cleaning kit consisting of 2 cleaning brushes and 12 cleaning needles



Order No. 162628

SATA care set - bag containing tools for spray gun cleaning and maintenance. Offers extra pockets for additional maintenance tools.

Scope of supply:

- 1x Cleaning brush, large 1
- 5x Cleaning brushes, medium 2
- 5x Cleaning brushes, double-sided 3
- 12x Nozzle cleaning needles 4
- 1x high performance grease, 100 ml 5

Please make sure that all brushes being used **have no protruding metal wires** as these may damage the spray gun. Please exclusively use recommended tools for cleaning only.

We recommend leaving the spray gun connected to the **air circuit with reduced pressure** even for manual cleaning. Make sure that cleaning agent never enters the air passages of the spray gun.

Please watch our video at www.sata.com/TV concerning **Cleaning and Maintenance of Spray Guns**. Or simply request our brochure for thorough guidelines.

www.sata.com/firstaid



Automatic & Robotic Spray Guns



Spray Guns | Cup Systems | Breathing Protection | Air Filtration | Accessories



SATAjet® 3000 ROB RP®/HVLP



SATAjet 3000 ROB RP

Technical Data	Operating pressure: 51 - 58 psi
	Air consumption: 15.5 cfm



Nozzle	0.5	0.8	1.1	1.3	1.5	1.7	2.0
---------------	-----	-----	-----	-----	-----	-----	-----

Standard version with Standard (STD) or Specially Treated (ST) Nozzle

Order No. STD	163931	94516	94524	135467	94550R	94559R	94570R
Order No. ST	-	94516ST	94524ST	137893	94550RST	94559RST	94570RST

Waterborne version with Standard (STD) or Specially Treated (ST) Nozzle

Order No. STD	-	94557	94565	130476	94585R	94593R	94603R
Order No. ST	-	146928	94565ST	130476ST	94585RST	94593RST	94603RST

Nozzle	0.5	0.8	1.1	1.3	1.5	1.7	2.0
---------------	-----	-----	-----	-----	-----	-----	-----

Nozzle Set

Order No. STD	129932	94136	94144	128322	135459	94170R	144253
Order No. ST	129932ST	137992	140889	138008	94160RST	94170RST	128777ST

SATAjet 3000 ROB HVLP

Technical Data	Operating pressure: 58 - 61 psi
	Air consumption: 20 cfm



Nozzle	0.5	0.8	1.0	1.2	1.6	2.0
---------------	-----	-----	-----	-----	-----	-----

Standard version with Standard (STD) or Specially Treated (ST) Nozzle

Order No. STD	-	94532	94540	124651	180976	94568R
Order No. ST	-	94532ST	94540ST	124651ST	94556RST	94568RST

Waterborne version with Standard (STD) or Specially Treated (ST) Nozzle



Order No. STD	-	94573	94581	124644	129395	129403
Order No. ST	-	94573ST	94581ST	124644ST	129395RST	129403ST

Nozzle	0.5	0.8	1.0	1.2	1.6	2.0
---------------	-----	-----	-----	-----	-----	-----

Nozzle Set

Order No. STD	129940	94151	94169	126433	124206	124214
Order No. ST	139659	139667	94169ST	138016	140814	140822

SATAjet 3000 ROB HVLP ACCESSORIES

74773	Quick change adapter for one SATA ROB spray gun, with fixing screw, without spacer blocks 52720 and connection 53132	
Inquire for product number	Adapter with or without recirculation for ROB spray guns	

Spare Parts SATAjet® 3000 ROB RP®/HVLP

Order No./Desc.	
10033	Air cap ring w/seal, 3000 RP
14183	Tool kit
38638	Air distribution ring
38638-3	Air dist. ring, pk of 3
38638-5	Air dist. ring, pk of 5
38638-20	Air dist. ring, pk of 20
41780	Gun body only (specify gun)
43091	Control piston
43109	Closing cap
64071	Seal retainer
64147	Washer
64709	Sleeve
64808	Spring, compression
68999	Repair kit
68999-S	Spring set
74179	Inner material seal
74690	Allen screw, M5x25
80598	Seal retainer
91728	Nozzle head, 3000 ROB HVLP & RP
92627	S/S nozzle head, 3000 ROB HVLP & RP
93732	Air cap ring w/seal, HVLP
97824	Air distribution ring, w/puller, pk of 3

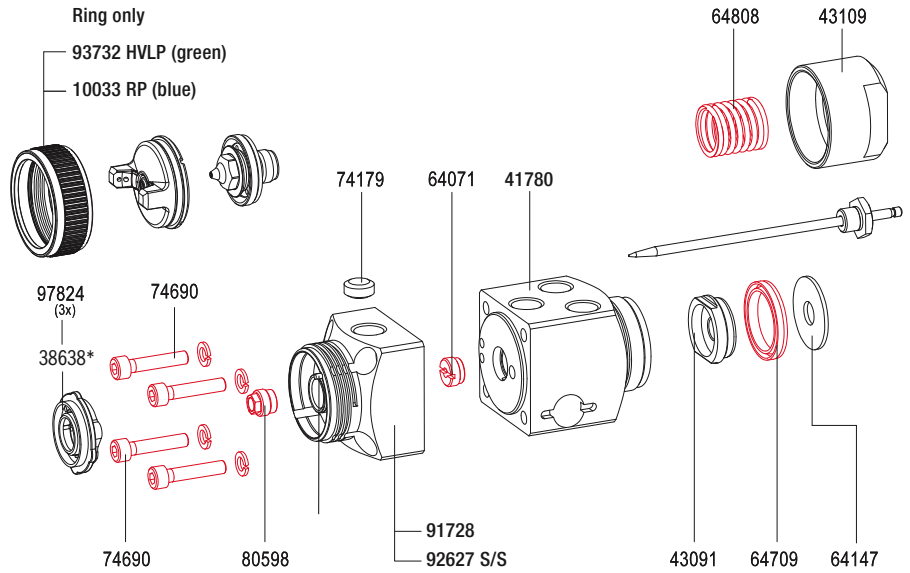

14183 Tool Kit	
901	Universal spanner wrench
3509	Cleaning brush
43638	Extraction tool
71431	Allen wrench 4mm
76307	Socket wrench

Order No./Desc.
68999
Repair kit

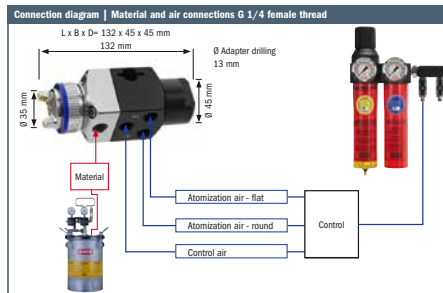

ROB Accessories and parts	
74773	Single Gun Adapter, LP ROB
56622	Dual Gun Adapter, LP ROB
53132	Connection Bolt G1/4, Adapter Plate
52720	Spacer Block, Pk of 3, Adapter Plate
145904	O Ring only, Pk of 10

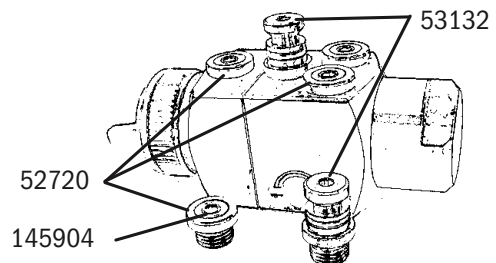

Technical modifications and printing errors reserved

SATAjet® 3000 A RP®/HVL



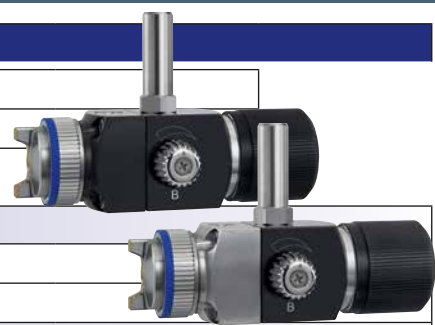

SATAjet 3000 A RP							
Technical Data		Operating pressure: 51 - 58 psi					
		Air consumption: 15.5 cfm					
Nozzle	0.5	0.8	1.1	1.3	1.5	1.7	2.0
Standard version with Standard (STD) or Specially Treated (ST) Nozzle							
Order No. STD	-	94417	94425	94433	94445A	94453A	94461A
Order No. ST	-	94417ST	94425ST	94433ST	94445AST	94453AST	94461AST
Waterborne version with Standard (STD) or Specially Treated (ST) Nozzle							
Order No. STD	-	94466	94474	94482	143289	94503A	94520A
Order No. ST	-	94466ST	94474ST	94482ST	94494AST	94503AST	94520AST
Nozzle	0.5	0.8	1.1	1.3	1.5	1.7	2.0
Nozzle Set							
Order No. STD	129924	94326	94334	94342	94359	94369	131052
Order No. ST	129924ST	94326ST	94334ST	94342ST	94359ST	94369AST	131052ST



SATAjet 3000 A HVL							
Technical Data		Operating pressure: 58 - 61 psi					
		Air consumption: 20 cfm					
Nozzle	0.5	0.8	1.0	1.2	1.6	2.0	
Standard version with Standard (STD) or Specially Treated (ST) Nozzle or Carbide (CB) Nozzle							
Order No. STD	-	94441	94458	124602	124594	124545	
Order No. ST	-	94441ST	94458ST	124602ST	124594ST	125454ST	
Order No. CB	-	94490AC	94508AC	94526AC	94544AC	188276	
Waterborne version with Standard (STD) or Specially Treated (ST) Nozzle							
Order No. STD	156604	180992	94508	124610	124552	124560	
Order No. ST	-	94490ST	94508ST	124610ST	124552ST	124560ST	
Nozzle	0.5	0.8	1.0	1.2	1.6	2.0	
Nozzle Set							
Order No. STD	129916	94367	94375	129577	129700	129718	
Order No. ST	129916ST	94367ST	94375ST	129577ST	129700ST	129718ST	
Order No. CB		96760A	96768A	96776	96784	96792	

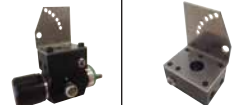

Connection options		
144618	Fixing bolt, D 15 G 1/4"	
64212A	Collar mount for 1/2" shaft, G 1/4" connection	
801102	Quick change mount w/indexing angle bracket, complete with hardware Individual parts sold separately, call for part no.	

Technical modifications and printing errors reserved

Spare Parts SATAjet® 3000 A RP®/HVLP

Order No./Desc.	
1503	Countersunk screw M4 x 8
1594	Teflon seal
3418	Washer, 3.7
3574	Spring, needle packing
10033	Air cap ring w/seal, RP
11403	S/S nipple, 1/4 x 3/8
11544	Spring, needle
14183	Tool kit
29827	Spring, pk of 12
38638	Air distribution ring
38638-3	Air dist. ring, pk of 3
38638-5	Air dist. ring, pk of 5
38638-20	Air dist. ring, pk of 20
54221	Control spin
64071	Seal retainer
64089	Gun body only (specify gun)
64105	Control piston
64147	Washer
64154	Hollow screw
64709	Sleeve
64766	Spacer
64808	Spring, compression
64857	Seal retainer, complete
64865	Control piston, complete
64873	End cap, complete
64881	Control cap
67082	Repair kit
67082-P	Packing set
67082-S	Spring set
69872	O ring, 11x1
70789	O ring, 5x2
73783	Hex socket screw
74179	Inner material seal
74690	Allen screw, M5x25
80598	Seal retainer
91728	Nozzle head, 3000 ROB HVLP & RP
92627	S/S nozzle head, 3000 ROB HVLP & RP
93732	Air cap ring w/seal, HVLP
93765	Nozzle head, K3 Auto HVLP & RP
93773	S/S nozzle head, wo/pin K3 Auto HVLP & RP
94714	Pin
97824	Air distribution ring, w/puller, pk of 3
133934	O ring, 11x1, pk of 3
140574	Control knob w/screw
144618	Mounting post 15mm, G 1/4"

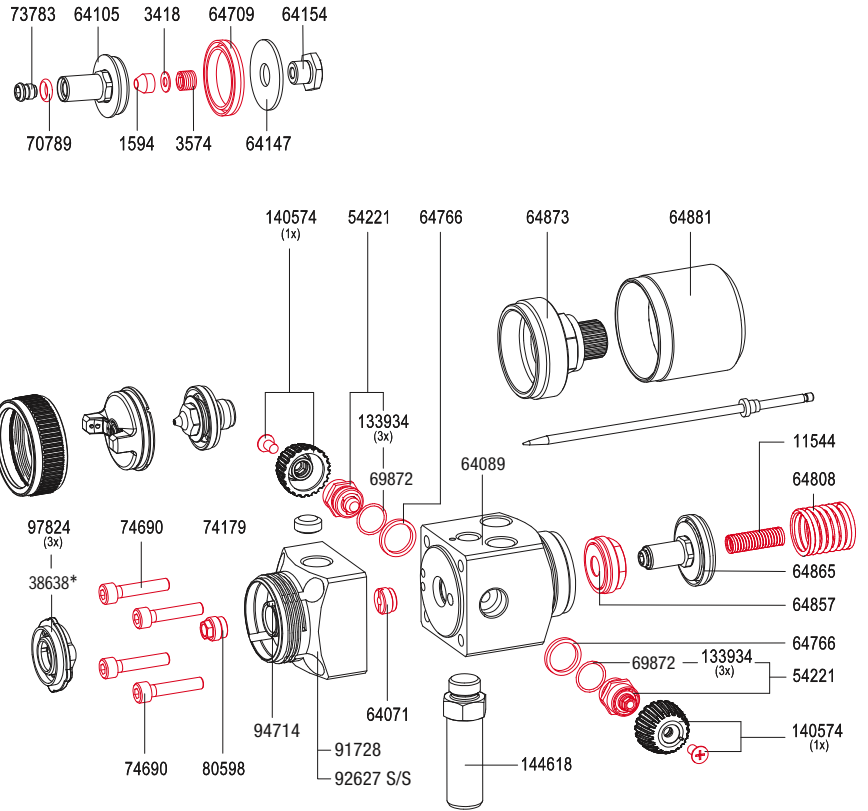

14183 Tool Kit	
901	Universal spanner wrench
3509	Cleaning brush
43638	Extraction tool
71431	Allen wrench 4mm
76307	Socket wrench

Order No./Desc.
67082
Repair kit

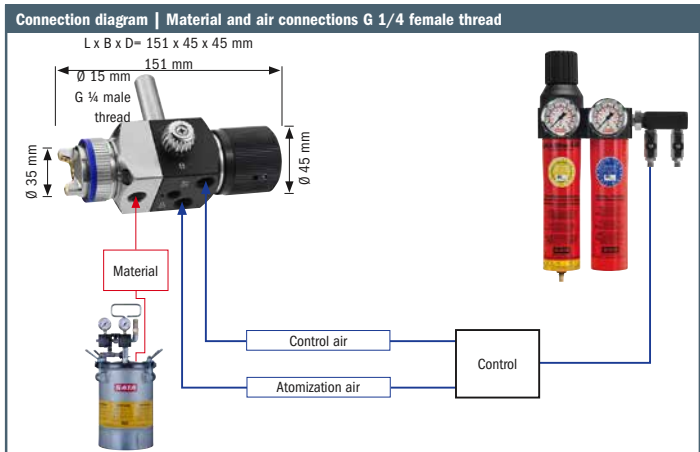

Technical modifications and printing errors reserved

SATAmijet® 3000 A HVLP



SATAmijet 3000 A HVLP

Technical Data	Air consumption at 4 cfm at 50 psi
	Operating pressure: 26 - 50 psi
	Atomization air (50 - 60 psi): min. \varnothing 6 mm
	Required min. control air pressure: 43 psi
	Maximum permissible operating air pressure: 150 psi
	Maximum permissible operating material pressure: 75 psi
	Maximum permissible operating temperature of the coating material: 176°F



Nozzle	0.3	0.5	0.8	1.0	1.2SR
--------	-----	-----	-----	-----	-------

Stainless steel version

Art. No.	170746	170753	170761	170779	194902
----------	--------	--------	--------	--------	--------

Nozzle set

Art. No.	171009	171017	171025	171033	*
----------	--------	--------	--------	--------	---

* available upon request

Test air caps for the setting the required spray parameters (reproducibility).

126474	Test air cap SATA minijet 3000 B HVLP (0.8 - 1.1)	
--------	---	--

Connection diagram | Material and air connections G 1/4 female thread

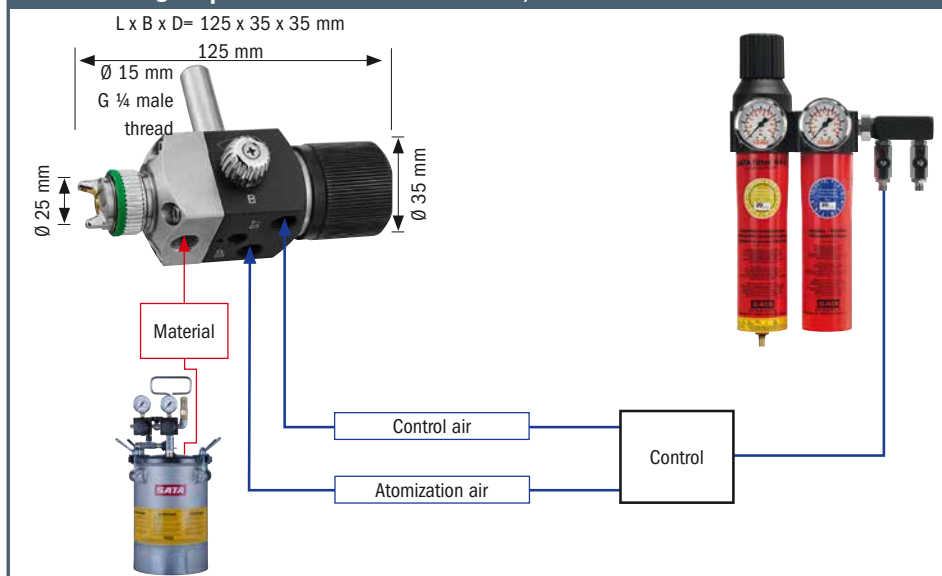

Spare Parts SATAminijet® 3000 A HVLP

Art. No./Descr.
1594
Teflon seal for paint needle
3418
Washer 3,7 DIN 125, brass
3574
Compression spring
11544
Compression spring for paint needle
54221
Spindle complete
64071
Seal retainer, cpl. w. needle packing (air side)
64105
Control piston for SATA LP, ready for assembly
64147
Washer for SATA LP90, ready for assembly
64154
Hollow screw for SATA LP90, ready for assembly
64709
Sleeve for SATA LP90
64766
Spacer
64808
Compression spring for SATA LP90
64857
Seal retainer LP90, big, complete, with piston packing
64865
Control piston for SATA LP90, cpl.
64873
End cap for LP90, complete
64881
Control cap for LP90, complete
70789
O-ring 5 x 2 mm, ethylene-propylene
73783
Hexagonal socket-head screw for LP90
74179
Intermediate piece for LP90
74690
Cylindrical screw M5x25, A2 stainless steel, DIN 912, for LP90 guns (version for water borne paints)
127399
Pack of 3 air distribution rings
133934
Pack of 3 packings
140574
Control knob and screw (each 1)
144618
Fixing bolt D 15 - G 1/4
170787
Seal retainer, cpl. material side SATAminijet 3000 A and ROB
170803
Nozzle head, cpl., version waterborne paint SATAminijet 3000 A and ROB WA

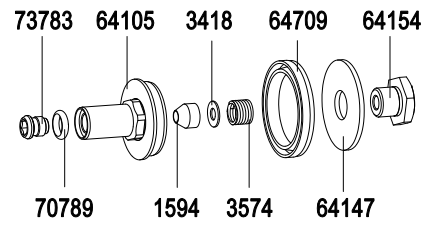
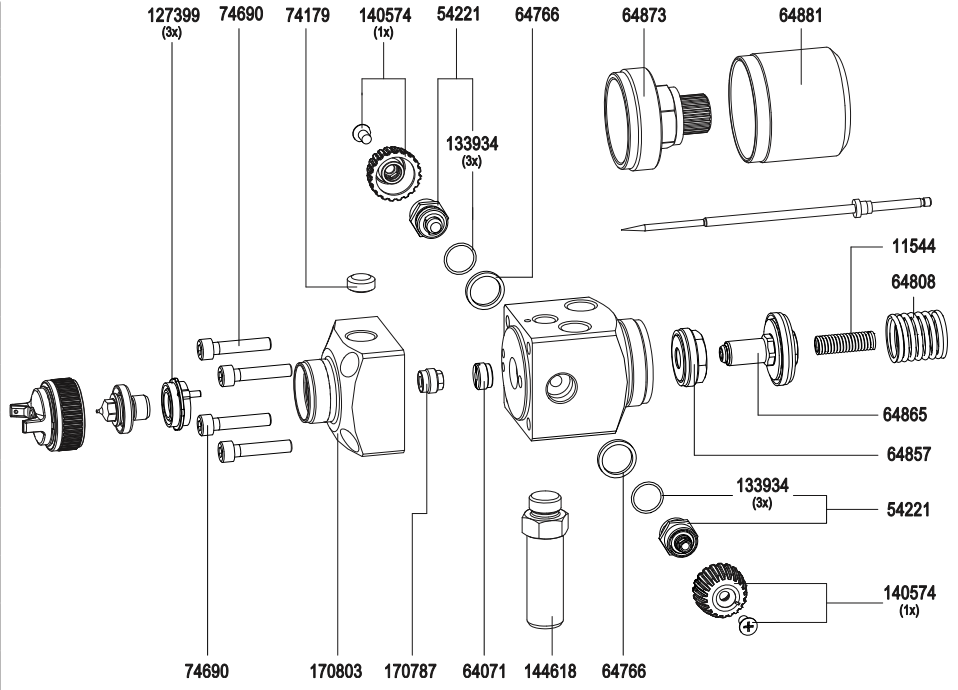

14183 Tool Kit	
901	Universal spanner wrench
3509	Cleaning brush
43638	Extraction tool
71431	Allen wrench 4mm
76307	Socket wrench



Technical modifications and printing errors reserved

SATAmijet® 3000 A S HVLP

SATAmijet 3000 A S HVLP

Technical Data	Air consumption: 7 cfm at 43 psi
	Atomization air (72 - 80 psi): min. \varnothing 8 mm
	Required min. control air pressure: 43 psi
	Maximum permissible operating air pressure: 150 psi
	Maximum permissible operating material pressure: 75 psi
	Maximum permissible operating temperature of the coating material: 175° F



Nozzle	0,3	0,5	0,8	1,0
---------------	-----	-----	-----	-----

Standard version

Art. No.	149021	149039	149047	149054
-----------------	--------	--------	--------	--------

Nozzle set

Art. No.	149476	149484	149492	149500
-----------------	--------	--------	--------	--------

Spray guns and nozzle sets with life time prolonging surface treatment of fluid tip and paint needle available upon request.

Test air caps for the setting the required spray parameters (reproducibility).

126474	Test air cap SATA minijet 3000 B HVLP (0.8 - 1.1)
--------	---



Connection diagram | Material and air connections G 1/4 female thread

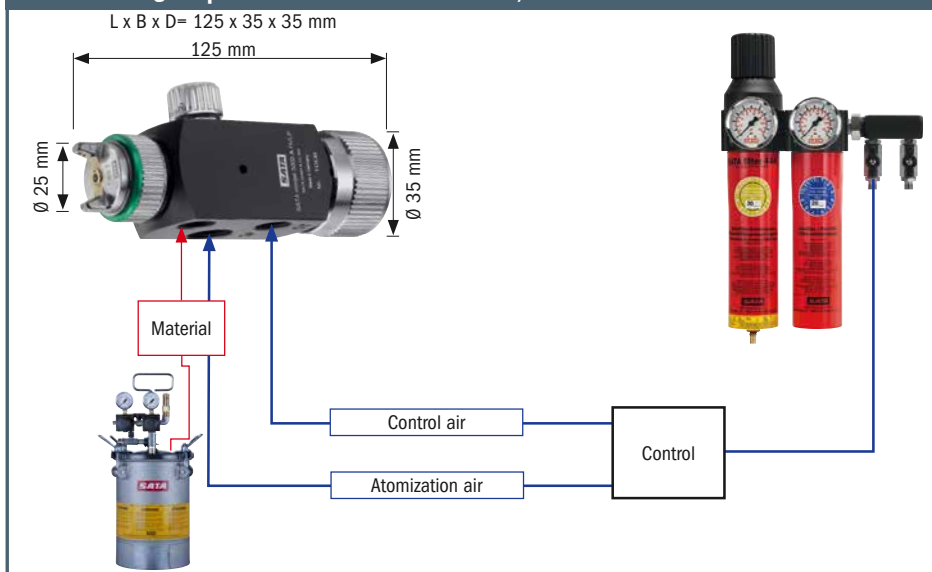

Spare Parts SATAminijet® 3000 A S HVLP

Art. No./Descr.
1503 Countersunk screw M4 x 8 DIN 965, stainless steel, for micrometer and round/flat spray control
1933 Teflon sealing for paint needle, packing unit: 5
2188 Spindle, complete, for regulation valve
3418 Washer 3,7 DIN 125, brass
3574 Compression spring
3582 Packing screw for SATAjet paint needle
20297 Compression spring for LP-S
22418 Teflon sleeve for LP-S
24349 Backing plate for LP
40253 Regulation cap LP-S, complete
45385 Hexagon nut M9X1 for taking sleeve (LP-S)
57976 Distance sleeve for SATA LP/S marking gun, ready for assembly
65557 Regulating knob and regulating valve
67116 Locking screw Ms R1/4 inch for LP90 and breathing set NIOSH
127399 Pack of 3 air distribution rings
144618 Fixing bolt D 15 - G 1/4

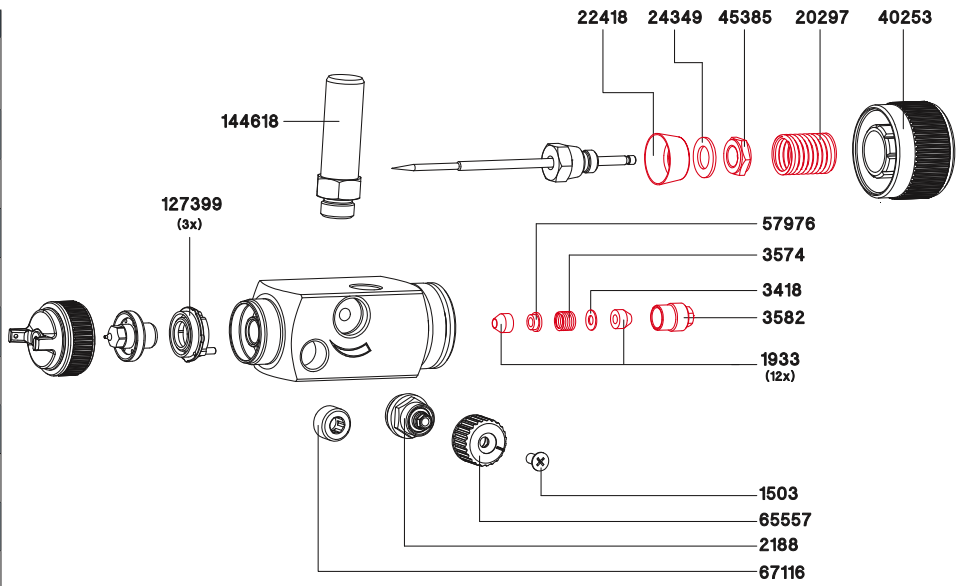

14183 Tool Kit

901	Universal spanner wrench
3509	Cleaning brush
43638	Extraction tool
71431	Allen wrench 4mm
76307	Socket wrench



Art. No./Descr.

40832
Repair kit for SATA LP-S

SATAmijet® 3000 ROB HVLP

SATAmijet 3000 ROB HVLP

Technical Data	Air consumption; 4 cfm at 50 psi
	Operating pressure: 26 psi
	Atomization air (50 - 60 psi): min. \varnothing 6 mm
	Required min. control air pressure: 45 psi
	Maximum permissible operating air pressure: 1.8 bar
	Maximum permissible operating material pressure: 75 bar
	Maximum permissible operating temperature of the coating material: 176° F



Nozzle	0.3	0.5	0.8	1.0	1.2	1.4
---------------	-----	-----	-----	-----	-----	-----

Stainless steel version without material circulation for the use on quick change adapter 188557

Art. No.	*	194894	188862	*	188870	*
-----------------	---	--------	--------	---	--------	---

Nozzle set

Art. No.	182675	185652	185660	185678	185686	185694
-----------------	--------	--------	--------	--------	--------	--------

* available upon application

Test air caps for the setting the required spray parameters (reproducibility).

126482	Test air cap SATA minijet 3000 B HVLP (0.8 - 1.0) SR4	
--------	---	--

Connection diagram | Material and air connections G 1/4 female thread

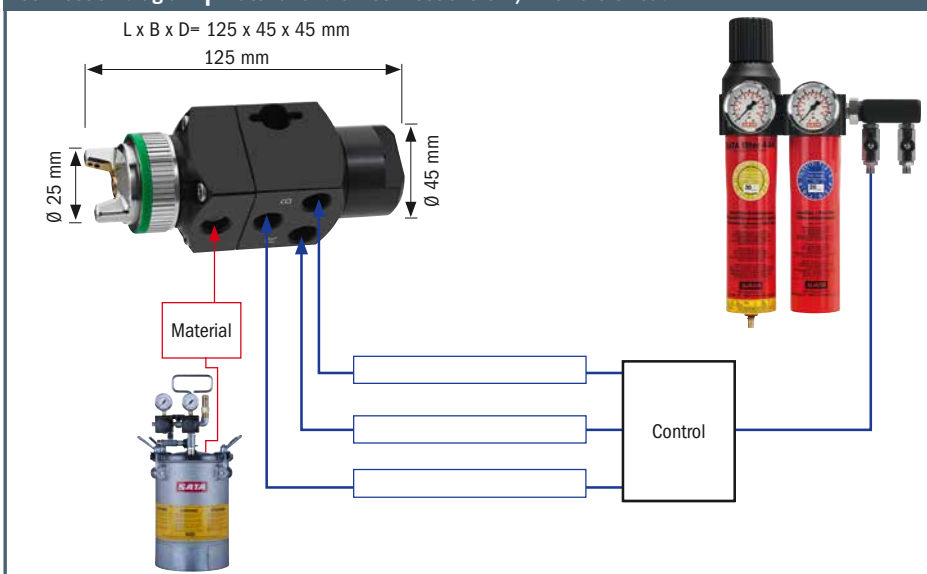

Spare Parts SATAminijet® 3000 ROB HVLP

Art. No./Descr.
43091 Control piston LP 90-ROB, ready for assembly
43109 Closing cap LP 90-ROB, completely processed, ready for assembly
64071 Seal retainer, cpl. w. needle packing (air side)
64147 Washer for SATA LP90, ready for assembly
64709 Sleeve for SATA LP90
64808 Compression spring for SATA LP90
74690 Cylindrical screw M5x25, A2 stainless steel, DIN 912, for LP90 guns (version for water borne paints)
127399 Pack of 3 air distribution rings
170787 Seal retainer, cpl. material side SATAminijet 3000 A and ROB
185611 Nozzle head, cpl. version for waterborne paints SATAminijet 3000 A and ROB WA without material circulation

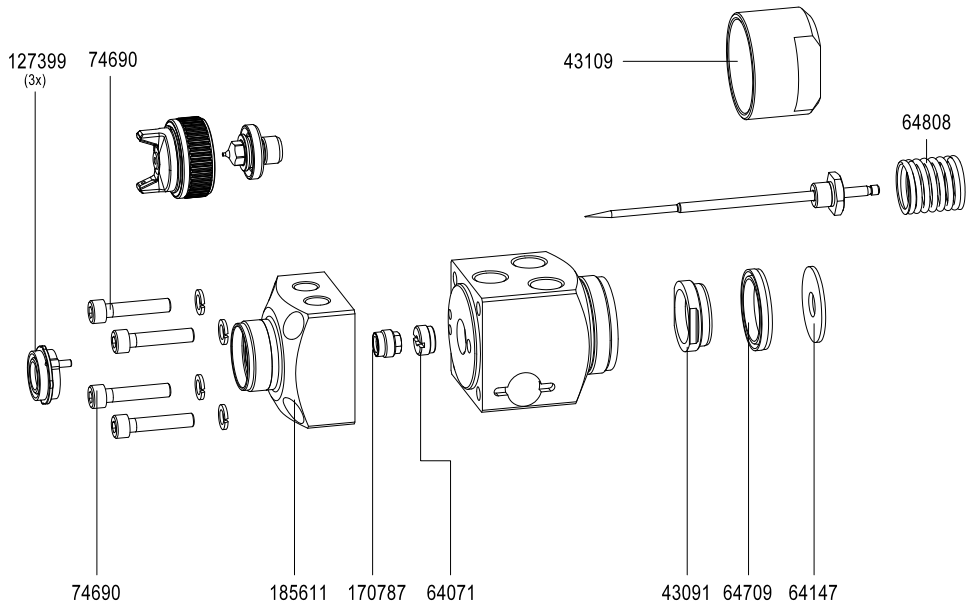

Art. No./Descr.

14183

Tool kit

- Extraction tool
- Socket wrench SW 7
- Cleaning brush
- Allen wrench 4 mm width
- Universal spanner



SATA® 1000 A RP

SATAjet 1000 A RP

Technical Data	Air consumption 15 cfm at 50 psi
	Operating pressure: 50 - 60 psi
	Required min. control air pressure: 45 psi
	Maximum permissible operating air pressure: 150 psi
	Maximum permissible operating material pressure: 75 psi



Nozzle	0.5	0.8	1.1	1.3	1.5	2.0	3.0
---------------	-----	-----	-----	-----	-----	-----	-----

Standard version

Art. No.	195198	164129	164137	164145	164152	164160		
-----------------	--------	--------	--------	--------	--------	--------	--	--

Stainless steel version

Art. No.		164178	164186	164194	164202	164210	185074	
-----------------	--	--------	--------	--------	--------	--------	--------	--

Nozzle set

Art. No.		164228	164236	164244	164251	164269	185082	
-----------------	--	--------	--------	--------	--------	--------	--------	--

Test air cap for the setting the required spray parameters (reproducibility).

184747	Test air cap 0.5 - 1.7 cpl. with 2 pressure gauges, cpl. for SATAjet 1000 K/A/ROB RP	
--------	--	---

SATAjet 1000 A RP without nozzle set

169870	SATAjet 1000 A RP without nozzle set
169888	SATAjet 1000 A RP WA without nozzle set, version for waterborne paints

Plate-shaped internal mixing extension

164277	SATA plate-shaped internal mixing extension for SATAjet 1000 A RP, length 20 cm, nozzle 1.6, 360°	
164285	SATA plate-shaped internal mixing extension for SATAjet 1000 A RP, length 30 cm, nozzle 1.6, 360°	

Nozzle sizes between 0.8 and 2.0 and lengths between 100 and 1,000 mm are available upon request.

Diagonal spray extension

164293	SATA diagonal spray extension for SATAjet 1000 A RP, length 20 cm, nozzle 1.6	
164301	SATA diagonal spray extension for SATAjet 1000 A RP, length 30 cm, nozzle 1.6	

Nozzle sizes between 0.8 and 2.0 and lengths between 100 and 1,000 mm are available upon request.

Spare Parts SATAmijnjet® 1000 A RP

Art. No./Descr.	
1594	Teflon seal for paint needle
3418	Washer 3,7 DIN 125, brass
3574	Compression spring
11544	Compression spring for paint needle
54221	Spindle complete
64071	Seal retainer, cpl. w. needle packing (air side)
64105	Control piston for SATA LP, ready for assembly
64147	Washer for SATA LP90, ready for assembly
64154	Hollow screw for SATA LP90, ready for assembly
64709	Sleeve for SATA LP90
64766	Spacer
64808	Compression spring for SATA LP90
64857	Seal retainer LP90, big, complete, with piston packing
64865	Control piston for SATA LP90, cpl.
64873	End cap for LP90, complete
64881	Control cap for LP90, complete
70789	O-ring 5 x 2 mm, ethylene-propylene
73783	Hexagonal socket-head screw for LP90
74179	Intermediate piece for LP90
74690	Cylindrical screw M5x25, A2 stainless steel, DIN 912, for LP90 guns (version for water borne paints)
80598	Seal retainer, cpl. w. 2 packings and metal ring, for paint needle 3.5 mm - material side
133934	Pack of 3 packings
140574	Control knob and screw (each 1)
140582	Pack of 5 sealing elements
143230	Pack of 3 air distribution rings
144618	Fixing bolt D 15 - G 1/4
164095	Nozzle head, cpl., jet 1000 A and ROB
164111	Nozzle head, cpl., version waterborne paint jet 1000 A and ROB

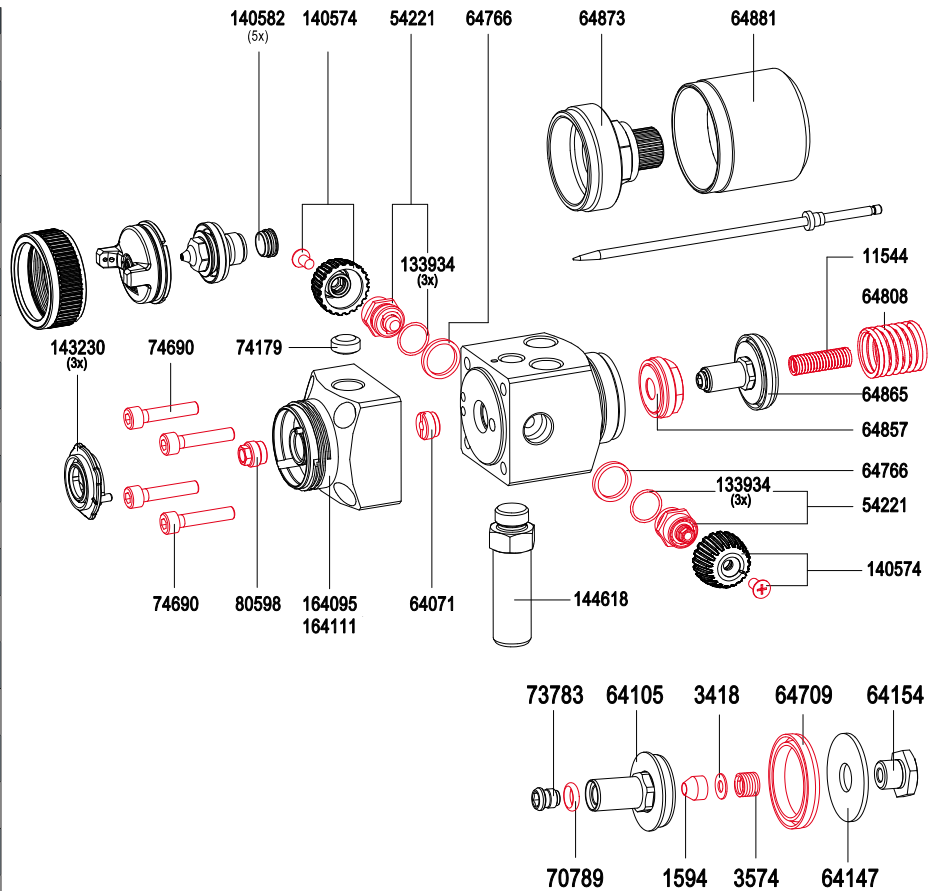

14183 Tool Kit	
901	Universal spanner wrench
3509	Cleaning brush
43638	Extraction tool
71431	Allen wrench 4mm
76307	Socket wrench

Art. No./Descr.	Euro
67082	87.90 (4)
Repair kit SATA LP90	

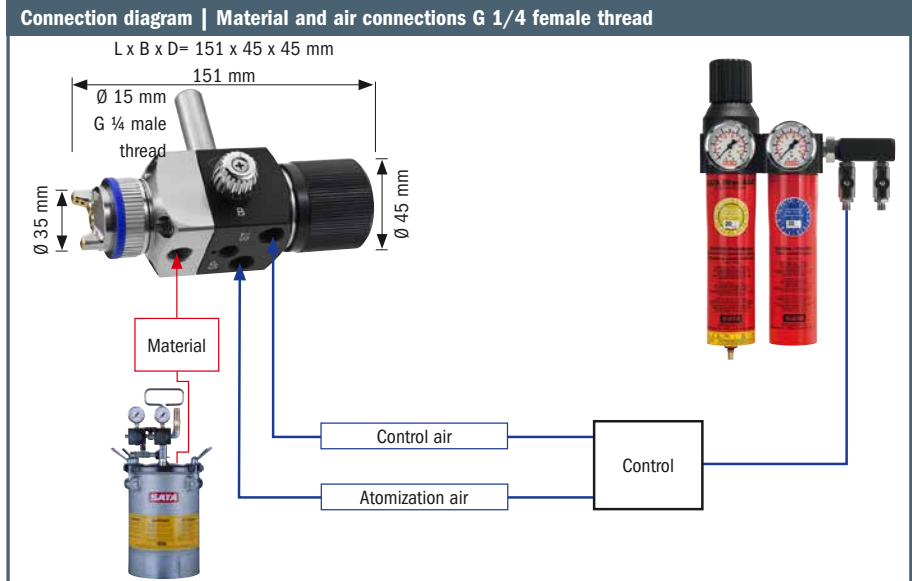

Technical modifications and printing errors reserved

SATAjet® LPS 2000 RP®



SATA LPS RB 2000 RP, SATA LPS R 2000

Technical Data	Air consumption SATA LPS RB 2000 RP: 7 - 9 cfm at 45 psi
	Air consumption SATA LPS R 2000: 4 - 5 cfm at 29 psi
	Required min. control air pressure: 45 psi
	Maximum permissible operating air pressure: 150 psi
	Maximum permissible operating material pressure: 75 psi
	Permanent atomization air for high operating frequencies



Nozzle	0.5	0.8	1.3	2.0
---------------	-----	-----	-----	-----

SATA LPS RB 2000 RP marking gun with round and flat fan

Art. No.	92908	92916	129726	177444
-----------------	-------	-------	--------	--------

Nozzle set

Art. No.	93013	93021	93039	-
-----------------	-------	-------	-------	---

Nozzle sets with life time prolonging surface treatment of fluid tip and paint needle upon request.

Nozzle	0.5	0.8
---------------	-----	-----

SATA LPS R 2000 marking gun with round fan

Art. No.	92940	*
-----------------	-------	---

Nozzle set

Art. No.	93047	93054
-----------------	-------	-------

Nozzle set with life time prolonging surface treatment of fluid tip and paint needle

Art. No.	-	149286
-----------------	---	--------

* available upon application

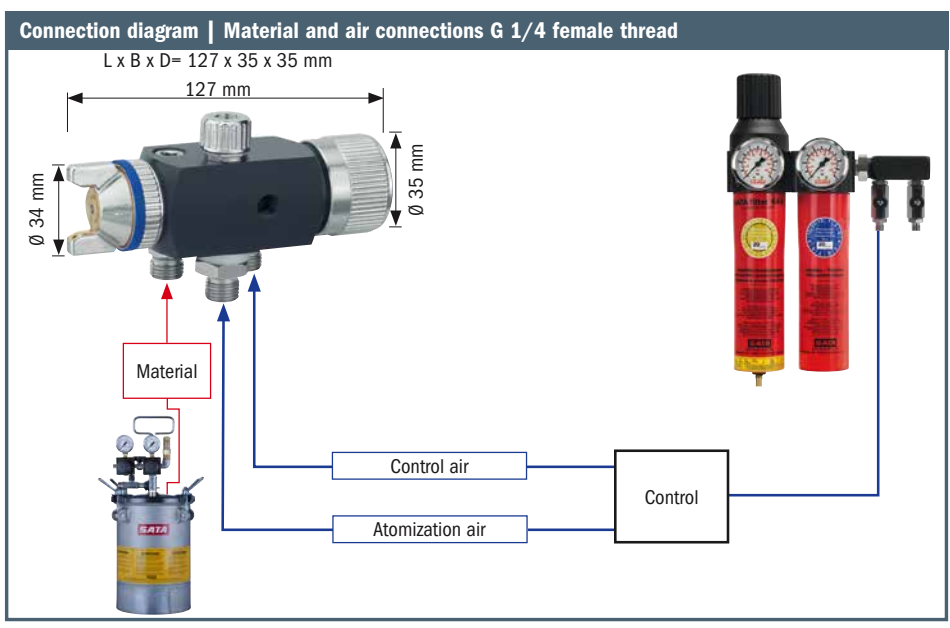



Parts SATAjet® LPS 2000 RP®

Order No./Descr.	
1503	Countersunk screw M4 x 8 DIN 965, stainless steel, for micrometer und round/flat spray control
1933	Teflon sealing for paint needle, packing unit: 5
3418	Washer 3,7 DIN 125, brass
3574	Compression spring
3582	Packing screw for SATAjet paint needle
3657	Control knob and regulation valve
3939	Spindle cpl. for LP90 lab test gun
20297	Compression spring for LP-S
22418	Teflon sleeve for LP-S
24349	Backing plate for LP
40253	Regulation cap LP-S, complete
40832	Repair kit
45385	Hexagon nut M9X1 for taking sleeve (LP-S)
57976	Distance sleeve for SATA LP/S marking gun, ready for assembly
62513	Air distribution ring, sn. below 30,000
64212	14mm, M10 x 1.5
64766	Spacer
67116	Locking screw Ms R1/4 inch for LP90 and breathing set NIOSH
69724	Closing screw LP-90-spray mix
133934	Pack of 3 packings
134593	Pack of 3 air distribution rings for SATA LM 2000
144618	Fixing bolt D 15 - G 1/4

SATA LPS RB 2000 RP

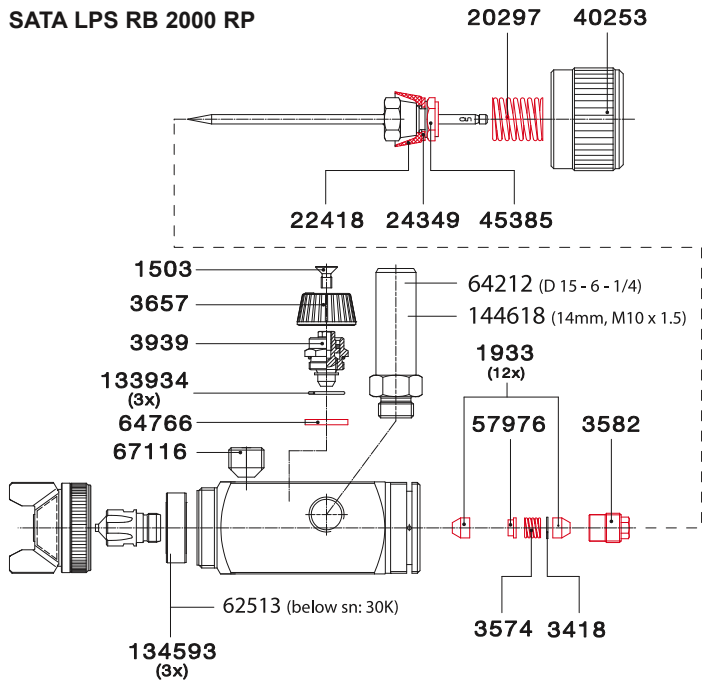

SATA LPS R 2000

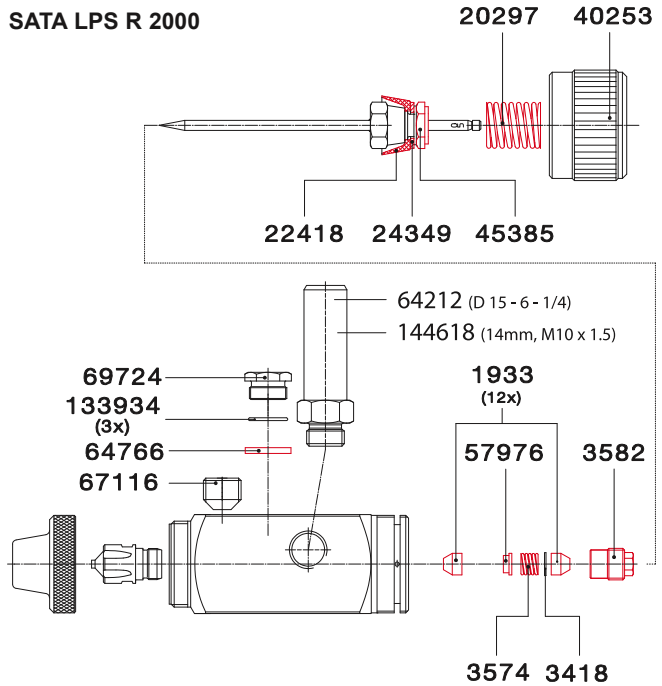

14183 Tool Kit

901	Universal spanner wrench
3509	Cleaning brush
43638	Extraction tool
71431	Allen wrench 4mm
76307	Socket wrench



Art. No./Descr.

40832
Repair kit for SATA LP-S

SATAJet® 3000 A spray mix

SATAJet 3000 K spray mix

Technical Data	Air consumption at 45 psi	Flat fan: 3 cfm
		Round fan: 8 cfm
	Required min. control air pressure: 45 psi	
	Maximum permissible operating air pressure: 150 psi	
	Maximum permissible operating material pressure: 3626 psi	
Maximum permissible operating temperature of the coating material: 120° F		



Standard version

144519	SATAJet 3000 A spray mix with round / flat spray control, without material nozzle
--------	---

Stainless steel version

144527	SATAJet 3000 A spray mix for waterborne materials, with round / flat spray control, without material nozzle
--------	---

Strainer

38265	Strainer for SATA pressure fed spray guns G3/8 female thread- G3/8 male thread, 60 msh, WA-version
-------	--

Nozzles SATAJet 3000 A spray mix (not contained in scope of supply of spray mix gun)

Fluid tip		Technical Data				
Nozzle No.	Art. No.	mm	inch	Angle	Width	16 l/min at 70 bar (1015 psi)
1840	23044*	0.18	0.007	40°	18	0.16
2325	7328	0.23	0.009	25°	14	0.23
2350	7435	0.23	0.009	50°	22	0.23
2360	74922	0.23	0.009	60°	24	0.23
		0.25	0.010	20°/50°	14/22	0.25
2825	16998	0.28	0.011	25°	14	0.30
2850	50906	0.28	0.011	50°	22	0.30
2865	13771	0.28	0.011	65°	26	0.30
		0.30	0.012	20°/50°	14/22	0.38
3325	20206	0.33	0.013	25°	14	0.45
3350	50898	0.33	0.013	50°	23	0.45
3365	13789	0.33	0.013	65°	28	0.45
3375	74930	0.33	0.013	75°	32	0.45
3390	73742	0.33	0.013	90°	40	0.45
		0.35	0.014	20°/50°	14/24	0.50
3825	13797	0.38	0.015	25°	15	0.61
3850	7344	0.38	0.015	50°	25	0.61
3882	74948	0.38	0.015	82°	34	0.61
		0.40	0.016	20°/50°	14/25	0.70
4650	19307	0.46	0.018	50°	25	0.95
4682	74955	0.46	0.018	82°	35	0.95
5370	150276	0.53	0.021	70°	33	1.28
6050	17004	0.60	0.024	50°	31	1.59

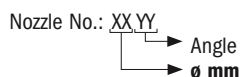

Connection kits, quick change adapters and optional accessories see pages 30 and 31.

Spare Parts SATAJet® 3000 A spray mix

Art. No./Descr.
1594
Teflon seal for paint needle
3046
Seal retainer complete, for nozzle head LP90/spray mix
3418
Washer 3,7 DIN 125, brass
3574
Compression spring
18341
Compression spring
54221
Spindle complete
64105
Control piston for SATA LP, ready for assembly
64147
Washer for SATA LP90, ready for assembly
64154
Hollow screw for SATA LP90, ready for assembly
64709
Sleeve for SATA LP90
64766
Spacer
64808
Compression spring for SATA LP90
64857
Seal retainer LP90, big, complete, with piston packing
64865
Control piston for SATA LP90, cpl.
69708
Seal retainer for LP90/spray mix cpl. w. needle packing
70789
O-ring 5 x 2 mm, ethylene-propylene
73783
Hexagonal socket-head screw for LP90
74179
Intermediate piece for LP90
74690
Cylindrical screw M5x25, A2 stainless steel, DIN 912, for LP90 guns (version for water borne paints)
97824
Pack of 3 air distribution rings
98434
Pre-nozzle, cpl.
98459
Air cap, cpl. Round / flat spray
98541
Needle tip, cpl.
98665
Air cap ring, cpl.
133934
Pack of 3 packings
140574
Control knob and screw (each 1)
144535
Nozzle head cpl. for SATA LP jet K3 spray mix, pre-assembled
144543
Nozzle head cpl. for waterborne materials, for SATA LP jet K3 spray mix, pre-assembled
144618
Fixing bolt D 15 - G 1/4
144626
Closing cap for SATA LP jet K3 spray mix
144642
Paint needle cpl. for SATA LP jet K3 spray mix, with needle sleeve

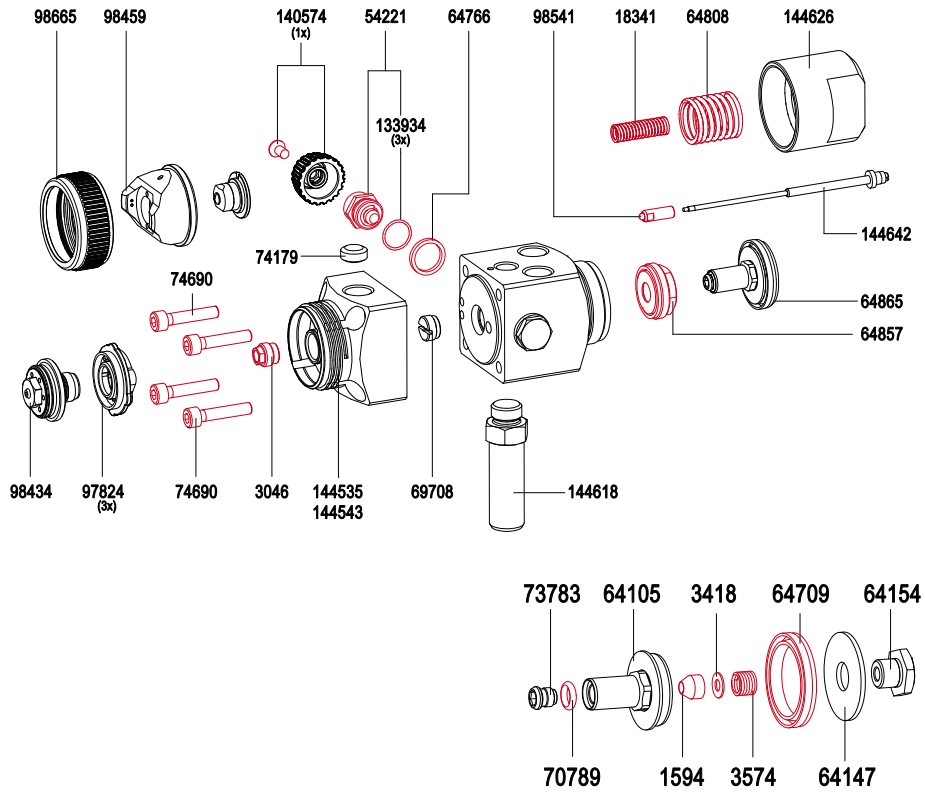

Art. No./Descr.
14183
Tool kit
· Extraction tool
· Socket wrench SW 7
· Cleaning brush
· Allen wrench 4 mm width
· Universal spanner

Art. No./Descr.
144733
Repair kit LP jet K3 spray mix

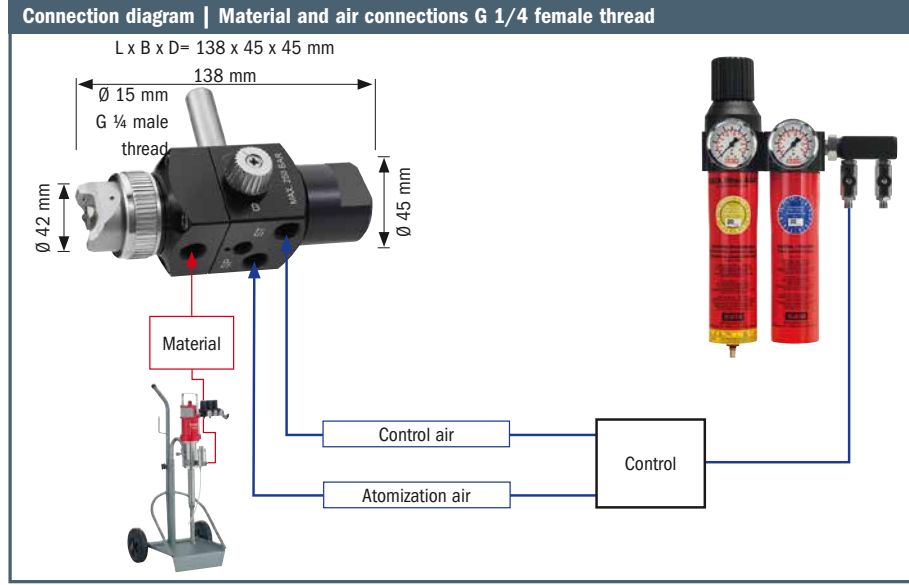

Technical modifications and printing errors reserved

SATAjet® Lab Test

SATAjet 4000 LAB RP					
Nozzle	1.2	1.2W	1.3	1.4	
Lab test spray gun with 0.6 l PVC reusable cup with spray pattern and test protocol					
Art. No.	182634	182659	182642	-	
Nozzle set					
Art. No.	119750	-	140350	141366	
SATAjet 4000 LAB HVLP					
Nozzle	WSB	1.3	1.4	1.5	
Lab test spray gun with 0.6 l PVC reusable cup with spray pattern and test protocol					
Art. No.	182618	182626	-		
Nozzle set					
Art. No.	-	148726	148734		
SATAjet 3000 LAB RP					
Nozzle	1.0	1.2	1.3	1.4	1.6
Lab test spray gun with 0.6 l PVC reusable cup with spray pattern and test protocol					
Art. No.	-	118216	140368	157313	-
Nozzle set					
Art. No.	140871	119750	140350	141366	141374
SATAjet 3000 LAB HVLP					
Nozzle	WSB	13	15		
Lab test spray gun with 0.6 l PVC reusable cup with spray pattern and test protocol					
Art. No.	149633	148619	-		
Nozzle set					
Art. No.	-	148726	148734		
SATAjet 2000 LAB HVLP					
Nozzle	WSB	13	15		
Lab test spray gun with 0.6 l PVC reusable cup with spray pattern and test protocol					
Art. No.	94821	90829	-		
Nozzle set					
Art. No.	141416	16485	16519		
SATA LP jet MSB LAB Test					
72595	SATA LP90 lab test spray gun, all material passages made of stainless steel, nozzle MSB 1.35, 0.6 l PVC cup, with spray pattern and test protocol				
Nozzle sets					
72603	Nozzle set SATA LP90 lab test spray gun MSB 1.35 with test protocol and spray pattern				
81786	Nozzle set SATA LP90 ROB lab test spray gun MSB 1.35 with test protocol and spray pattern				





Spare Parts SATAJet® Lab Test

Art. No./Descr.
1503
Countersunk screw M4 x 8 DIN 965, stainless steel, for micrometer und round/flat spray control
1594
Teflon seal for paint needle
1826
4 pieces non-drip devices for 0.6 l PVC cup
3418
Washer 3,7 DIN 125, brass
3574
Compression spring
3939
Spindle cpl. for LP90 lab test gun
11544
Compression spring for paint needle
19208
LP 90 regulation cap f. flexible material flow control, nickel-plated, ready for assembly
20057
Control screw for flexible material flow control
23911
Disc 3.2 DIN 125, nickel-plated, for trigger spray-mix
23960
Countersunk screw M 3 x 6, DIN 85 AM 3 x 6 4.8 galvanised
35873
Scale, anodised, with press cut holes
48231
Scale ring for LP90 test gun, nickel-plated, with black engraving
49379
Plastic gravity cup 0.6 l with lid
49395
Screw-on lid for 0.6 l PVC cup with drip-catching ring and non-drip device
49957
Scale plate
53819
Flexible compression piece M5 for stroke retainer HKD-ED DINOL and LP 90, made of stainless steel
64071
Seal retainer, cpl. w. needle packing (air side)
64105
Control piston for SATA LP, ready for assembly
64147
Washer for SATA LP90, ready for assembly
64154
Hollow screw for SATA LP90, ready for assembly
64709
Sleeve for SATA LP90
64766
Spacer
64808
Compression spring for SATA LP90
64857
Seal retainer LP90, big, complete, with piston packing
64865
Control piston for SATA LP90, cpl.
64873
End cap for LP90, complete
69997
Compression spring
70789
O-ring 5 x 2 mm, ethylene-propylene
73510
Spacer for LP90 lab test gun
73528
Blocking plate
73536
Control knob
73544
Intermediate washer for LP 90 test gun
73619
Reduction nipple for LP 90 test gun - version for water borne paints
73627
Index ring
73650
Threaded pin M2 x 3, DIN 554

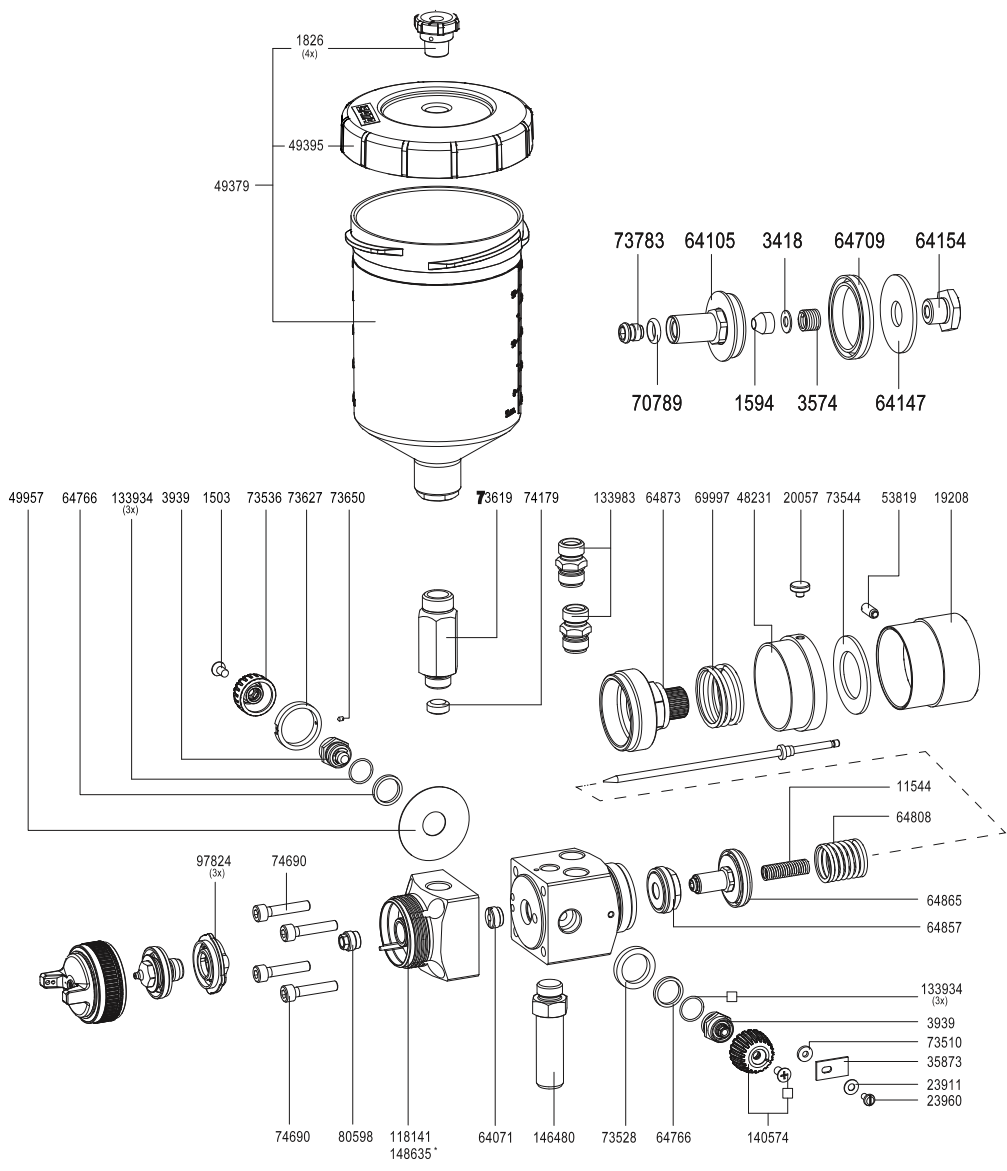

Art. No./Descr.
73783
Hexagonal socket-head screw for LP90
74179
Intermediate piece for LP90
74690
Cylindrical screw M5x25, A2 stainless steel, DIN 912, for LP90 guns (version for water borne paints)
80598
Seal retainer, cpl. w. 2 packings and metal ring, for paint needle 3.5 mm - material side
97824
Pack of 3 air distribution rings
118141
Nozzle head, cpl.
133934
Pack of 3 packings
133983
Air connection piece G1/4 male thread
140574
Control knob and screw (each 1)
146480
Fixing bolt D 14 - G 1/4
148635
Nozzle head, cpl.

14183 Tool Kit	
901	Universal spanner wrench
3509	Cleaning brush
43638	Extraction tool
71431	Allen wrench 4mm
76307	Socket wrench

Technical modifications and printing errors reserved



Nozzle Sets for Older Model SATA Spray Guns

SATA Spray Guns

Nozzle Size	SATAjet 3000 HVLP	SATAjet 3000 RP	SATAjet 2000 HVLP	SATAjet RP	SATAjet B NR-92 NR-95 HVLP	SATAjet K NR-92 NR-95 HVLP	SATA MC-B HVLP	SATA Jet 90	SATA ♦ Jet/K ▲ Jet/H	Nozzle Size
0.2										0.2
0.3										0.3
0.4										0.4
0.5						73908				0.5
0.8						79780			♦61358	0.8
0.8SR										0.8SR
0.9										0.9
1.0	132910	132357	82024	29587	46334	79798				1.0
1.0SR										1.0SR
1.1									♦55814	1.1
1.2	132928	132365	82057	14902	NLA	79806				1.2
1.2SR										1.2SR
1.3	132936	132373	82073	14910	46177				♦64592	1.3
1.3 LV	161331									1.3 LV
1.3 C										1.3 C
WSB	132993		9191							WSB
1.4	132944	132381	82263	14936	34801	79277	52324	56077		1.4
1.4 HC	145797									1.4 HC
1.5	132951		82420	14977	46185				♦64600 ▲23663	1.5
1.6		132399						51482		1.6
1.6 NA							83600			1.6 NA
1.7	132969		90399	97998	46193	77917			▲23697	1.7
1.8		132407					64014			1.8
1.9	132977		90407	69880	50138					1.9
2.0		132415					83618		▲23689	2.0
2.1										2.1
2.2	132985		90415	69898	46201					2.2
2.5		132423								2.5
P										P
2.6										2.6
3.0										3.0
4.0										4.0
5.0										5.0
Repair Kits	133835	133835	57620	57620	61531	70623	71464	57430*	70623	Repair Kits

* Above sn 85,000 (below 85,000 - part no. 55178) ** Above sn 6,000 (below 6,000 - part no. 69377)

NLA = No Longer Available

Technical modifications and printing errors reserved

Nozzle Sets for Older Model SATA Spray Guns

SATA Spray Guns

Nozzle Size	SATA MC-B MC-93	SATA LM 92 B, H, K	SATA minijet 2 & 3 HVLP	SATA minijet HVLP Green	SATA dekor	SATA KLC-B HVLP	SATA KLC RP	SATA LM2000 B, H, K RP	SATA LM2000 B, H, K HVLP	Nozzle Size
0.2					NLA					0.2
0.3			91041							0.3
0.4					5280					0.4
0.5			91058		NLA					0.5
0.8		6734	91066	57240	5264			26690		0.8
0.8SR			53454							0.8SR
0.9									26823	0.9
1.0		6726	91074	NLA	NLA			26716		1.0
1.0SR			51318							1.0SR
1.1			91082	57778					26856	1.1
1.2										1.2
1.2SR			88534							1.2SR
1.3	80788	64444					87973	26724	26864	1.3
1.3 LV										1.3 LV
1.3 C										1.3 C
WSB										WSB
1.4						32748			30106	1.4
1.4 HC										1.4 HC
1.5									26872	1.5
1.6	80796	60673					87981	26732		1.6
1.6 NA							88005			1.6 NA
1.7						32755			30643	1.7
1.8	NLA	6684					96768	26740		1.8
1.9						32771			30742	1.9
2.0	80804	6676					87999	26757		2.0
2.1						33415			31047	2.1
2.2										2.2
2.5		6668					88013	26765		2.5
P										P
2.6										2.6
3.0		6650						26781		3.0
4.0								26799		4.0
5.0								26807		5.0
Repair Kits	71464	562	50815	50815	91165**	12633	12633	54957	54957	Repair Kits

* Above sn 85,000 (below 85,000 - part no. 55178) ** Above sn 6,000 (below 6,000 - part no. 69377)

NLA = No Longer Available

Technical modifications and printing errors reserved

SATAjet® 3000 B RP®/HVLP



SATAjet 3000 B RP (DIGITAL)

Technical Data	Inlet Pressure: 2.0 - 2.2 bar / 29-35 psi
	Air consumption: 2.0 bar: 285 NI/min / 10.4 cfm at 29 psi
	Spray distance: 12 - 21 cm / 6 3/4 in - 8 1/4 in



Nozzle	1.0	1.2	1.3	1.4	1.6	1.8	2.0	2.5
---------------	-----	-----	-----	-----	-----	-----	-----	-----

Nozzle Set

Order No.	132357	132365	132373	132381	132399	132407	132415	132423
------------------	--------	--------	--------	--------	--------	--------	--------	--------

SATAjet 3000 B HVLP (DIGITAL)

Technical Data	Inlet Pressure: 2.0 bar / 29 psi
	Air consumption: 2.0 bar: 430 NI/min / 15.2 cfm at 29 psi
	Spray distance: 13 - 17 cm / 5 in - 6 3/4 in



Nozzle	1.0	1.2	WSB	1.3	1.4	1.5	1.7	1.9	2.2
---------------	-----	-----	-----	-----	-----	-----	-----	-----	-----

Nozzle Set

Order No.	132910	132928	132993	132936	132944	132951	132969	132977	132985
------------------	--------	--------	--------	--------	--------	--------	--------	--------	--------

Spray Gun No Longer in Production • Replacement Parts Available

Spare Parts SATAjet® 3000 B

Order No./Desc.	
240	Packing, air piston
901	Wrench, universal spanner
1503	Screw, fan control
3426	Circlip only, 1 each
3509	Brush, large standard
3624	Pin, air micrometer
3699	Pin, lower trigger
3988	Sieve, pk of 20
3988-5	Sieve, pk of 5
6395	Disc, CC (standard), pk of 4
6585	Insert, aluminum cup
7757	Disc, CC (DIGITAL), pk of 4
9050	Tool kit
9647	Allen wrench, 4
12591	Pin, upper trigger
14605	Bushing, needle packing
14993	Spring, needle packing
15438	Kit, needle packing
17525	Spring, spacer lock
17897	Spring, paint needle
23275	Packing, needle
27813	Spring, air piston
38638	Ring, air distribution, each
38638-3	Ring, air distribution, pk of 3
38638-5	Ring, air distribution, pk of 5
38638-20	Ring, air distribution, pk of 20
43638	Puller, wire air ring
64543	Allen wrench, 2
69872	O ring, fan control, (large)
82552	Kit, air piston service
86843	Piston, air rod
89771	Fluid Control, w/"O" ring
89805	Air cap snap ring
96875	Inner cup seal
123042	Identification ring, RP blue
123059	Identification ring, HVLP green
131623	O ring, fan control, (small)
133462	RP air cap ring w/ seal
133470	HVLP air cap ring w/ seal
133835	Repair kit, complete
133850	Kit, trigger service complete
133884	Kit, battery, cover w/ gasket
133926	Kit, trigger sleeve

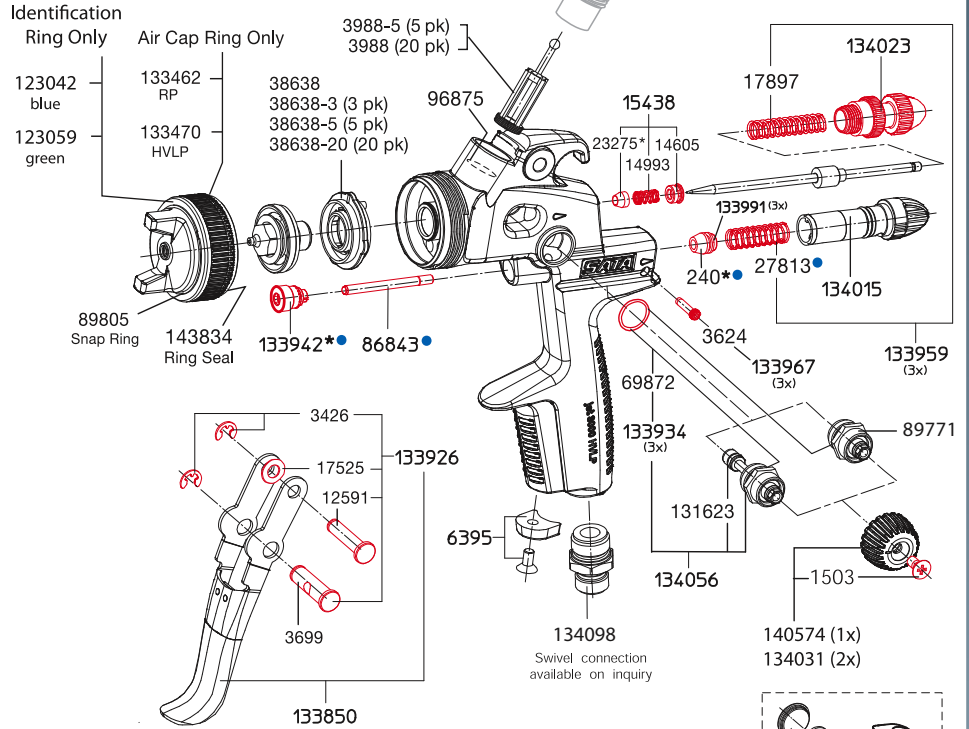

Order No./Desc.	
133934	O ring, fan control, pk of 3 (large)
133942	Bushing, air piston
133959	Kit, spring, pk of 3 each of #27813 & #17897
133967	Pin, air micrometer, pk of 3
133991	Packing, air piston, pk of 3
134015	Air micrometer
134023	Kit, fluid control and lock nut
134049	Kit, left hand fan control
134056	Control, RH fan w/ O-ring
134098	Fitting, standard ? air inlet
136960	Packing kit
140574	Knob, fan control w/ screw
143834	Seal, air cap ring

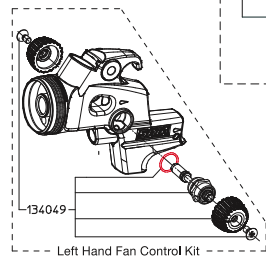
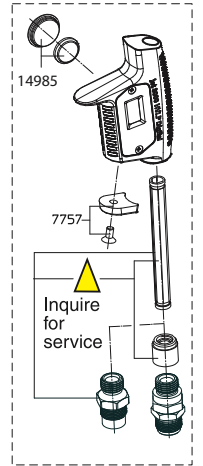

For optional left hand control spray gun only, body machined all the way through.

9050 Tool Kit	
901	Universal spanner wrench
3509	Cleaning brush
9647	Allen wrench 4mm
64543	Allen wrench 2mm
43638	Extraction tool

Order No./Desc.
133835
Repair kit
82552
Air piston service set
* 136960
Packing set

Technical modifications and printing errors reserved



SATAjet® 2000 B HVLP & SATAjet B RP

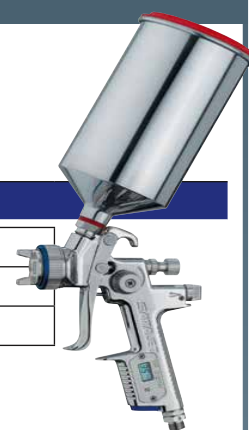

SATAjet 2000 B RP (DIGITAL)

Technical Data	Inlet Pressure: 2.0 - 2.2 bar / 29-35 psi
	Air consumption: 2.0 bar: 285 NI/min / 10.4 cfm at 29 psi
	Spray distance: 12 - 21 cm / 6 ³ / ₄ in - 8 ¹ / ₄ in

Nozzle	1.0	1.2	1.3	1.4	1.6	1.8	2.0	2.5
---------------	-----	-----	-----	-----	-----	-----	-----	-----

Nozzle Set									
Order No.	29527	14902	14910	14936	14977	97998	69880	69898	



SATAjet 2000 B HVLP (DIGITAL)

Technical Data	Inlet Pressure: 2.0 bar / 29 psi
	Air consumption: 2.0 bar: 430 NI/min / 15.2 cfm at 29 psi
	Spray distance: 13 - 17 cm / 5 in - 6 ³ / ₄ in

Nozzle	1.0	1.2	WSB	1.3	1.4	1.5	1.7	1.9	2.2
---------------	-----	-----	-----	-----	-----	-----	-----	-----	-----

Nozzle Set									
Order No.	82024	82057	9191	82073	82263	82420	90399	90407	90415

Spray Gun No Longer in Production • Replacement Parts Available

Spare Parts SATAjet® 2000 B

Order No./Desc.	
40	Air piston packing
901	Universal spanner wrench
1503	Fan control screw
1826	Non-drip device, pk of 4
3426	Circlip, pin
3509	Standard cleaning brush
3624	Pin, micrometer
3657	Knob, fan control
3699	Pin, lower trigger
3988	Paint sieve, pk of 20
3988-5	Paint sieve, pk of 5
6007	Std cleaning brush, pk of 10
6213	Trigger service set, Jet 2000, RP
6585	Insert for Alu cup adapter
7757	ColorCode disc, pk of 4
9050	Tool set, Jet 2000, RP
9647	Allen wrench, 4
10033	Air cap ring w/seal, Jet RP
12591	Pin, upper trigger
14605	Bushing, needle packing
14985	Battery kit, digital
14993	Spring, needle packing
15438	Needle packing service set
17525	Lock spring
17897	Needle spring
23275	Needle packing
26518	Fluid control service set
27243	0.6L plastic cup QCC
27813	Air piston spring
38638	Air ring, SATAjet 2000, SATAjet RP Digital & Std. (above S/N 43,700)
38638-3	Air ring, pack of 3
38638-5	Air ring, pack of 5
38638-20	Air ring, pack of 20
43174	Air cap ring w/seal, Jet 2000
43638	Wire tool, air ring
49395	0.6 liter cup lid
49437	Cup Lid Drip Ring, 0.6L, Pk of 5
50146	Fluid regulating control
50542	Lock nut, fluid control
53603	Air micrometer
55244	Packing set: Jet 2000, RP, 90
57620	Repair kit, Jet 2000, RP
64543	Allen wrench, 2
69872	Control O-ring
71555	Plastic lid, pk of 3
82552	Air piston service set
82636	Air piston packing holder
86843	Air piston
89391	Trigger
89771	Fan Control
89805	Snap ring (air cap)
95091	Air inlet fitting, DIGITAL
96644	Cup nipple, alum. QCC only
96685	1.0L alum. cup, QCC
96693	Red ring, alum. QCC only
96719	QCC adapter, PPS cup
96875	Inner cup seal
134098	Air inlet fitting, std. gun
143834	Seal, air cap ring, 5 pk

SATAjet 2000 B Serial No. 200,000 and up Rear Mounted Needle Packing

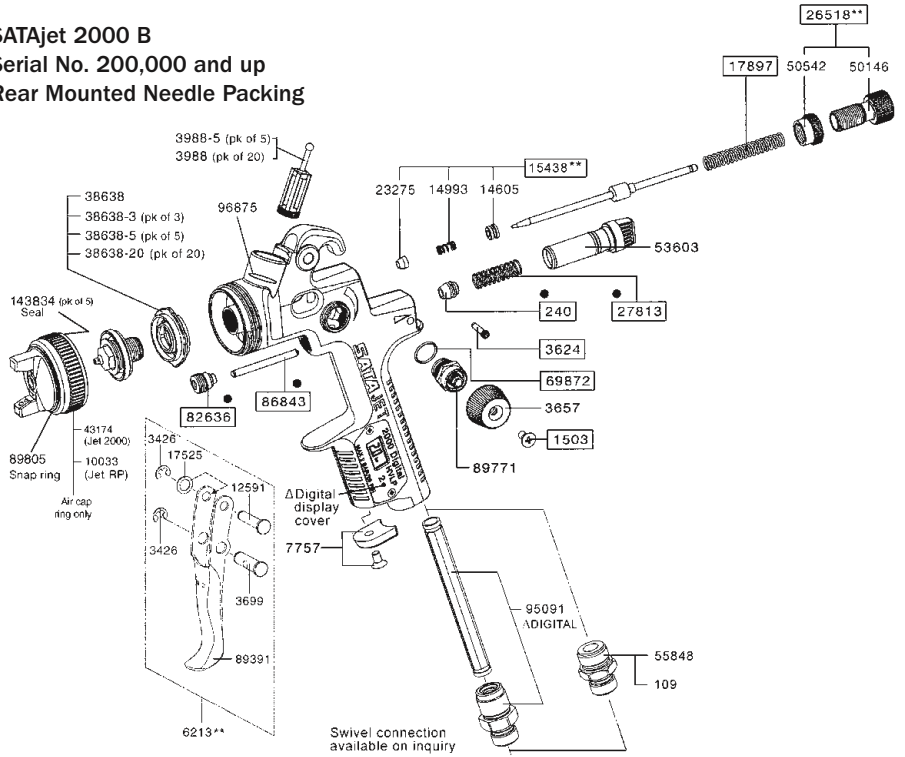

SATAjet 2000 B Serial No. 200,000 and down Front Mount Needle Packing

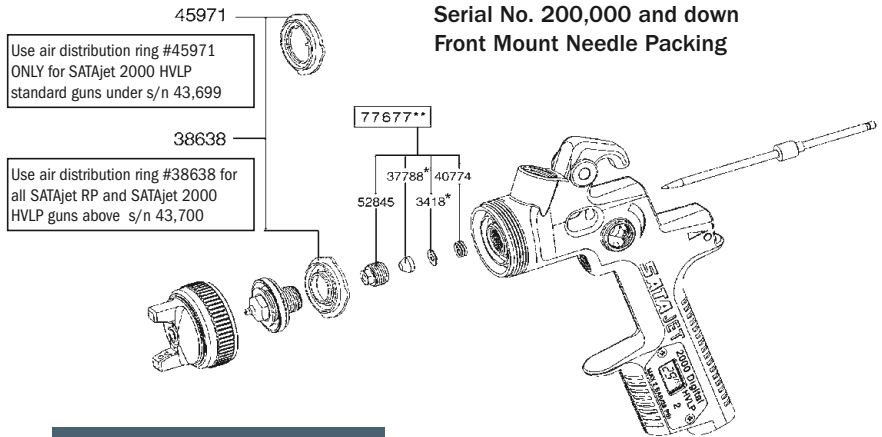

Front Mount Needle Packing Only

Order No./Desc.

901	Universal spanner wrench
3418	Packing washer
3509	Std cleaning brush
3756	Deep socket wrench
6007	Std cleaning brush, pk of 10
9654	Tool set, Jet 2000, RP
37788	Packing seal
38638	Air distribution ring, All Satajet RP's and Satajet HVLP above sn: 43,700
40774	Needle packing spring
45971	Air distribution ring Std HVLP below sn: 43,700
52845	Needle packing holder
64543	Allen wrench, 2
71431	Allen wrench, 4
77677	Needle packing service set

Order No./Desc.

<input type="checkbox"/>	57620 Repair kit
<input checked="" type="checkbox"/>	82552 Air piston service set
*	55244 Packing set
**	Parts that are available separately from Packing set

9050 Tool Kit

901	Universal spanner wrench
3509	Cleaning brush
9647	Allen wrench 4mm
64543	Allen wrench 2mm
43638	Extraction tool



SATAjet® KLC RP®/HVLP

SATAjet® KLC P

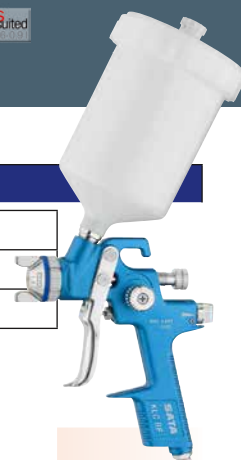

SATAjet KLC RP						
Technical Data		Inlet pressure: 1.5 - 2.0 bar / 7-29 psi				
		Air consumption: 2.0 bar: 290 NI/min / 10.2 cfm @ 29 psi				
		Spray distance: 18-23 cm / 5-7 in				
Nozzle	1.3	1.6	1.6NA	1.8	2.0	
Nozzle Set						
Order No.	87973	87981	88005	96768	87999	

SATAjet KLC P		
Technical Data		Inlet pressure: 1.5 - 2.0 bar / 29 psi
		Air consumption: 2.0 bar: 245 NI/min / 8.7 cfm @ 29 psi
		Spray distance: 18-23 cm / 5-7 in
Nozzle	P	
Nozzle Set		
Order No.	88013	

SATAjet KLC HVLP				
Technical Data		Inlet pressure: 2.0 bar / 29 psi		
		Air consumption: 2.0 bar: 350 NI/min / 12.4 cfm @ 36 psi		
		Spray distance: 18-23 cm / 5-7 in		
Nozzle	1.4	1.7	1.9	2.1
Nozzle Set				
Order No.	32748	32755	32771	33415



Spray Gun No Longer in Production • Replacement Parts Available

Spare Parts SATAjet® KLC

Order No./Desc.
109
Air inlet fitting
240
Air piston packing
422
Air piston packing
1503
Countersunk screw M4 x 8 DIN 965, stainless steel, for micrometer and round/flat control
3426
Circlip pin
3624
Pin, air micrometer
3699
Lower trigger pin
3749
Air piston packing holder
6486
Trigger service set
12591
Upper trigger pin
14605
Needle packing bushing
14993
Needle packing spring
15438
Paint needle packing
17525
Lock spring
20396
Air distribution ring (1x)
27813
Air piston spring
29629
Air piston
53603
Air micrometer
54221
Fan control
55137
Trigger
62513
Air distribution insert
65557
Fan control knob
83758
Fluid regulating control
133926
Trigger sleeve kit
133934
pk of 3 packings
133959
Spring set: 3 x #17152 & 3 x 10520
134601
Air distribution ring (3x)

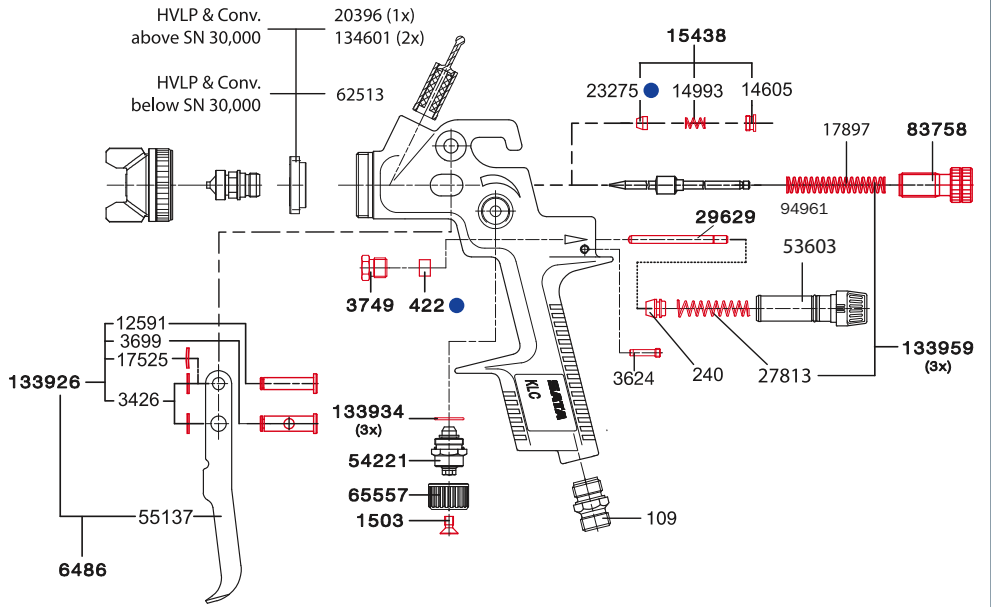

9944 HVLP, 9050 Conv, Tool Kit	
901	Universal spanner wrench
3509	Cleaning brush
9647	Allen wrench 4mm
43638	Extraction tool
64543	Allen wrench 2mm



Order No./Desc.
57620
Repair kit
54080
Packing set

Technical modifications and printing errors reserved

SATAjet® B (SATAjet® GR)



SATAjet B

Technical Data	Inlet pressure: 58 psi
	Air consumption: 12 cfm at 60 psi
	Spray distance: 5-7 in

Nozzle	1.0 E	MSB	1.4 E	1.5 E	1.7 E	2.0
---------------	-------	-----	-------	-------	-------	-----

Nozzle Set

Order No.	4143	4127	3848	4119	4101	4093
------------------	------	------	------	------	------	------

SATAjet GR

Technical Data	Inlet pressure: 58 psi
	Air consumption: 12 cfm at 60 psi
	Spray distance: 5-7 in

Nozzle	1.3 W	1.5 W	1.7 W	2.0 W	2.5 W	310 W
---------------	-------	-------	-------	-------	-------	-------

Nozzle Set

Order No.	31252	31898	31997	4093	13003	13011
------------------	-------	-------	-------	------	-------	-------

Spray Gun No Longer in Production • Replacement Parts Available

Spare Parts SATAjet® B (SATAjet® GR)

Order No./Desc.
422
Air piston packing
1503
Countersunk screw M4 x 8 DIN 965, stainless steel, for micrometer and round/flat control
1826
Non-drip device for 0.6 l PVC cup, pk of 4
2600
Service set for nozzle insert consisting of nozzle insert, distribution plate and sealing ring
3566
Fluid inlet nipple, SATAjet B
3657
Knob, Fan Control
3749
Air Piston Packing Holder
3988
5-pk paint strainer for SATA standard sized spray guns
6445
Needle packing set
6486
Trigger service set
16162
Swivel joint for SATA DIGITAL spray guns
29629
Air piston
49379
Plastic gravity cup 0.6 l with lid and female fittings
49395
Screw on lid for 0.6 l PVC cup with drip-catching ring and non-drip device
54221
Fan control
61416
Paint flow control screw cpl. w/ counter nut
64766
Spacer ring
133926
Trigger sleeve kit
133934
pk of 3 packings
133959
Spring set: 3 x #17152 & 3 x 10520
133967
pk of 3 adjustment screws
133983
Air connection piece G1/4a
133991
pk of 3 air piston heads

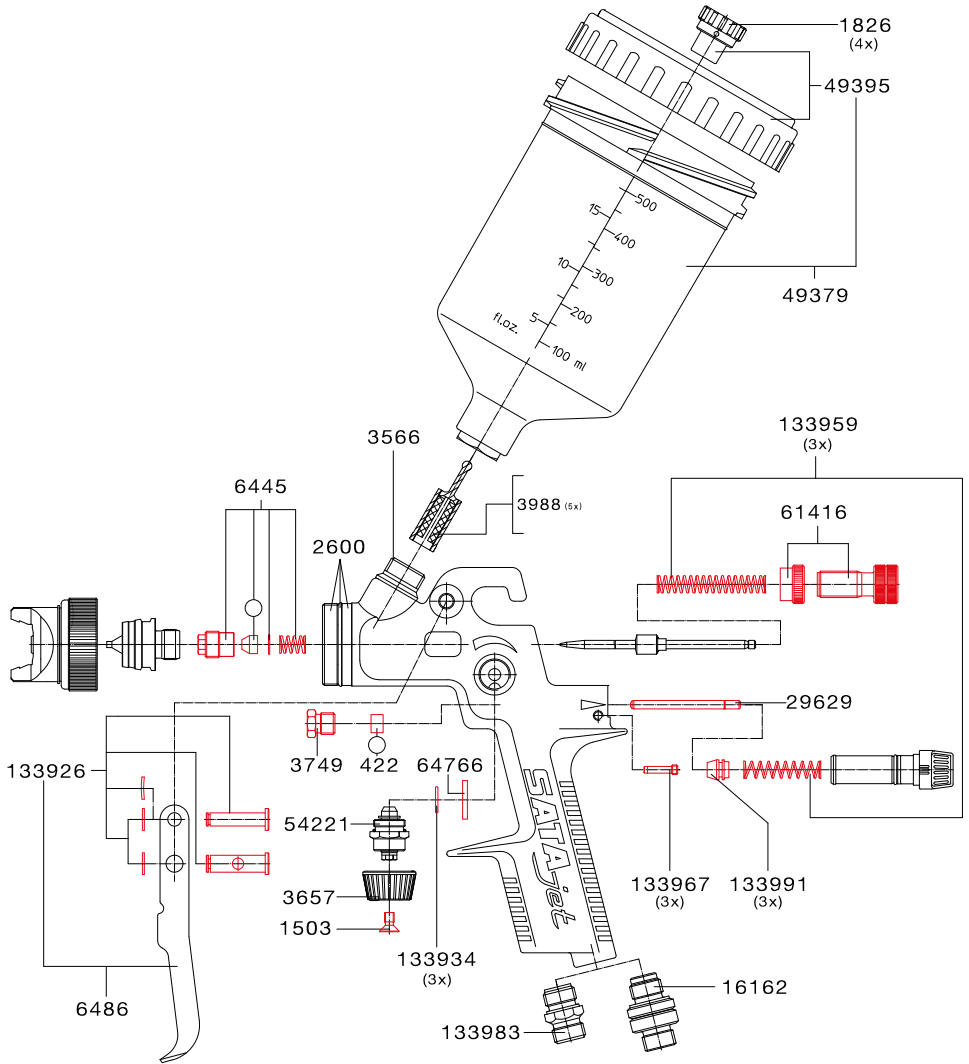

Technical modifications and printing errors reserved

9654 Tool Kit	
901	Universal spanner wrench
3509	Cleaning brush
64543	Allen wrench 2mm
71431	Allen wrench 4mm
76307	Socket wrench



Order No./Desc.
69666
Repair kit from S/N 650000 on
9829
Packing set

SATAjet® H



SATAjet H

Technical Data

Inlet pressure: 58 psi
 Air consumption: 12 cfm at 60 psi
 Spray distance: 5-7 in

Nozzle	1,5	MSH	2,0
---------------	-----	-----	-----

Nozzle Set

Order No.	23663	23697	23689
------------------	-------	-------	-------

Spray Gun No Longer in Production • Replacement Parts Available

Spare Parts SATAjet® H

Order No./Desc.	
109	Air inlet fitting, 1/4 BSP
240	Air piston packing
901	Spanner wrench
1503	Fan control screw
1594	Needle packing
2600	Spindle service set
2691	Cup and deck assemble.
2733	Deck assembly, conventional
3418	Packing washer
3426	Circlip, pin
3509	Std. cleaning brush
3574	Needle packing spring
3582	Needle packing holder
3590	Air distribution spacer
3624	Pin, micrometer
3657	Knob, fan control
3699	Pin, lower trigger
3756	Socket wrench
3871	Air distribution spindle
6445	Needle packing service set
6569	Trigger service set
6973	Air piston service set
7211	Nozzle seal, pk of 6
9647	Allen wrench, 4
9654	Tool kit
12591	Pin, upper trigger
17525	Lock spring
17897	Needle spring
21832	Air piston packing spring
23275	Air piston packing
23374	Air piston packing holder
26120	Aluminum cup, 1.0 liter
27771	Air micrometer with gauge
27813	Air piston spring
29603	Air piston
29827	Needle packing spring, pk of 12 #3574
45286	Drip proof, pk of 4
46300	Fluid inlet nipple
50195	Sieve, conventional, pk of 2
50542	Lock nut, fluid control
50666	Packing set, Jet/H
51680	Cup gasket, pk of 4
53496	Pick-up tube brush
53603	Air micrometer
54221	Fan control
55137	Trigger
61416	Fluid control service set
64543	Allen wrench, 2
69872	O ring fan control
83758	Fluid regulating control

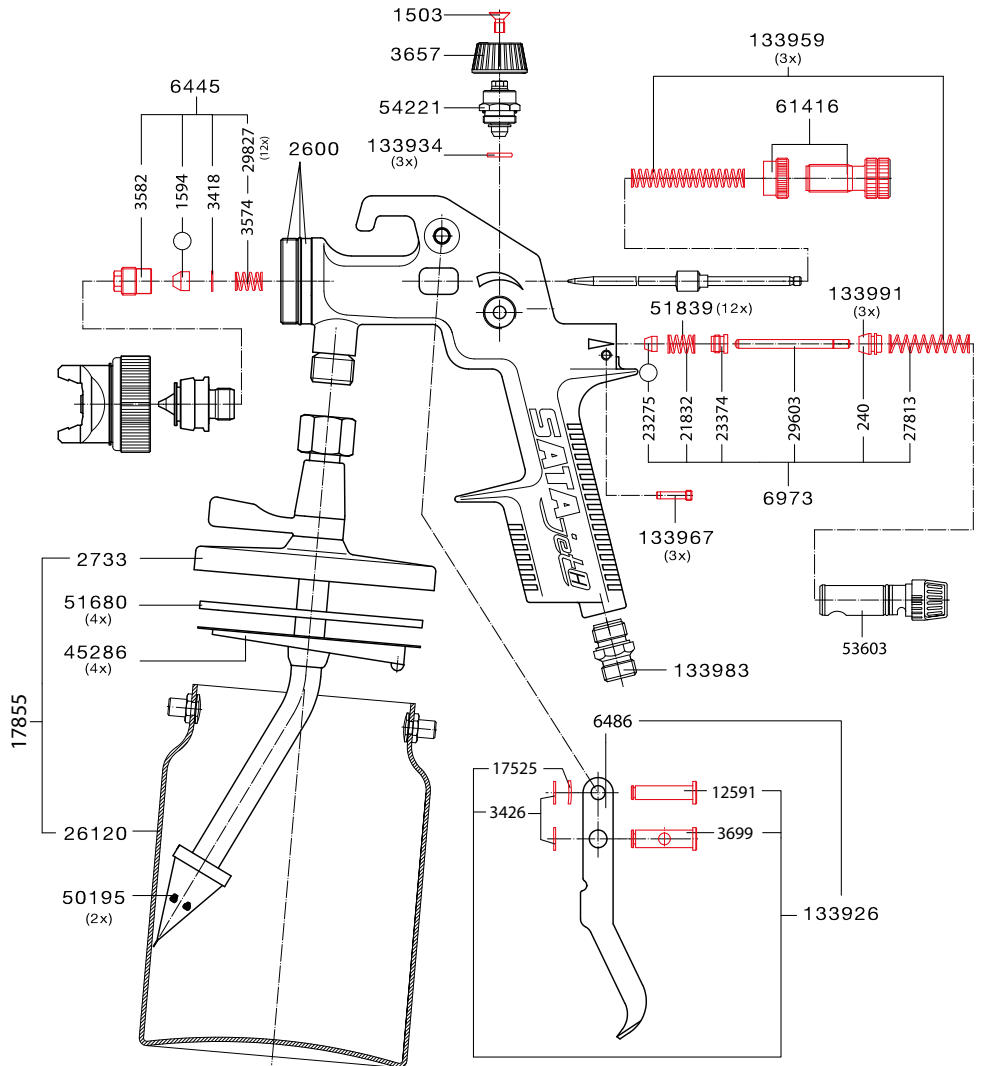

9654 Tool Kit	
901	Universal spanner wrench
3509	Cleaning brush
64543	Allen wrench 2mm
71431	Allen wrench 4mm
76307	Socket wrench



Order No./Desc.
70623
Repair Kit
○ 50666
Packing set

Technical modifications and printing errors reserved

Accessories for Spray Guns

Adam 2 - Accurate pressure control

The digital pressure gauge SATA adam 2 allows the exact adjustment of the spray pressure on paint spray guns with an accuracy of +/- 1 psi. Permanent spray pressure control during painting significantly contributes to perfect color matching and high quality finishes preventing costly reworks due to incorrect pressure setting.

All SATA paint spray guns with an integrated air micrometer can now be upgraded with the SATA adam 2. The assembly is very simple and quick - the standard air micrometer is replaced by the retrofit SATA adam 2 with just a few easy steps.

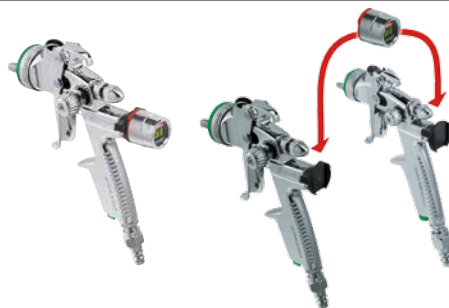

160853	SATA adam 2, psi complete With the SATA adam 2 consisting of two separate components docking base and display - usage, cleaning and maintenance have become a lot easier.	
160887	SATA adam 2 mini, psi complete	
160697	SATA adam 2 display only The digital readout which contains all electronic components. As the pressure is set by turning the setting wings on the docking base only, the digital display always remain in the upright position ensuring perfect pressure reading at all times. For increased safety during cleaning in gun washing machines, a simple, reliable click-in mechanism quickly releases the SATA adam 2 display from the dock. This mechanism also allows using the SATA adam 2 display on different SATA spray guns equipped with a docking base and the SATA dpg.	
160788	SATA adam 2 dock Adaptor plate for the SATA adam 2 display replaces the standard air micrometer. Available in two versions for SATA standard guns and SATA minijet guns, it now also features the micrometer function for pressure setting. The integrated seal provides full pressure setting functionality even when the display has been removed. Comes with protective cover when display is not mounted.	
160861	SATA adam 2 mini dock Fits minijet 3, minijet 4, and SATAminijet 3000 B	
160739	SATA adam 2 battery set	

SATA dpd (digital pressure gauge)

195222	SATA dpd for precise measure of air pressure Air micrometer with with dock and display	
195230	SATA dpd dock Air micrometer G 1/4 with SATA dock	
195925	SATA dpd dock only	

Air Micrometer and Pressure Gauges

27771	SATA Air Micrometer with Gauge This high quality air micrometer indicates precise HVLP, RP or conventional air pressure settings at the spray gun air inlet. The gauge bezel has a green color coded pressure range for correct adjustment of SATA HVLP guns and blue for SATA RP (reduced pressure) guns. The SATA air micrometer with gauge housing is anodized black and adjustable from 0 - 145 psi.	
4002	SATA In-Line Hose Pressure Gauge High-volume in-line pressure gauge with unrestricted airflow to the spray gun (non-adjustable). HVLP and RP color-coded pressure gauge face with a high flow coupler and nipple.	
9860	SATA air micrometer without gauge It also works well with spray guns without the built-in air micrometer feature or when air pressure is not critical. Rugged metal black anodized housing. Connects to 1/4 BSP air inlet fitting.	
43786	SATA line pressure gauge It also works well with spray guns without the built-in air micrometer feature or when air pressure is not critical. Rugged metal black anodized housing. Connects to 1/4 BSP	

Technical modifications and printing errors reserved

Spare Parts SATA® adam 2

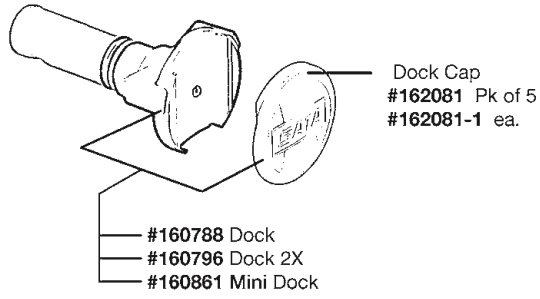

Battery replacement kit Part No. 160739

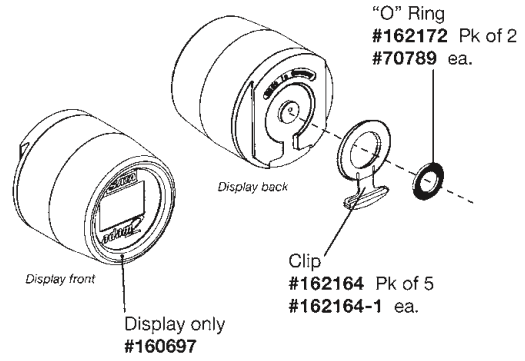











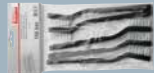



Accessories for Spray Guns

Pressure measurement and adjustment		
Air connection		
13656	SATA HVLP female nipple G 1/4 female thread (use 6981 for 5-pk)	
53942	SATA HVLP male nipple G 1/4 male thread	
13599	SATA HVLP female QC G 1/4 female thread	
13623	SATA HVLP male QC G 1/4 male thread	
99895	Universal swivel fitting - flexible connection nipple G 1/4	
Spray Gun Holders		
9886	SATA gravity gun holder	
40188	SATA bench mounted gun holder	
69328	Spray gun stand, complete, for SATAminijet 3000 B HVLP and SATAjet 20 B Can be used for gravity or side cups	
9898-3	3 gun wall mount, gravity feed spray guns	
9898-3A	3 gun wall mount or cabinet add-on, gravity feed spray guns	
9898-4	4 gun wall mount, gravity feed spray guns	
9898-6	6 gun wall mount (3 x 2), gravity feed spray guns	
9890-M	Dan-Am SATAminijet hanger, wall mount or cabinet mount	
Cleaning and maintenance		
60095	SATAclean, 3 gun soaking tray	
60111	Plug-set (3-pieces) for SATA	
162628	SATA care set, spray gun care bag with cleaning utensils and spray gun grease. Scope of supply: 1x Large cleaning brush, 5x medium cleaning brush, 5x double ended cleaning brush, 12x nozzle cleaning needles, 1x high performance SATA grease (100 ml)	
48173	100 g tube SATA high performance grease for spray guns, silicone and acid free	
3988-5 3988	5-pk paint strainer for SATA reusable cups 20-pk paint strainer for SATA reusable cups	
9894	SATA nozzle cleaning needles, pk of 12	
64030	Cleaning set: 2x cleaning brushes & 12x nozzle cleaning needles	

Additional spray gun accessories and equipment on page 148

Accessories for Spray Guns

Cleaning and maintenance		
3509	Cleaning brushes, each	
6007	Cleaning brushes, pk of 10	
64220	Small cleaning brushes, each	
9209	Small cleaning brushes, pack of 10	
158840	Cleaning brushes, pack of	
53496	Large SATA siphon pick-up pipe, each	
29280	Large SATA siphon pick-up tube, pack of 10	
64035	Dan-Am Spray gun maintenance kit: 13 x various sized SATA cleaning brushes, 2 x SATA cleaning broaches, 1 x gun lube (1/2 oz)	
64036	Dan-Am Air brush cleaning kit, includes; 5x mini brush set, 1x plastic handled brush, 2x double ended brushes, 2x cleaning brushes w/handle, 2x cleaning broches, 2x large brushes, 1x EZ airbrush cleaner, 1x airbrush lube oil	
9845	SATA viscosity cup 4.0 mm, machined from solid aluminum	
9852	SATA viscosity cup, extruded aluminum	
Quality control		
161596	SATA cert, with archive, spray pattern block, single sheet holder and distance marker	
161646	Spray pattern blocks each w/ 25 sheers for SATA cert	
161661	Distance marker for SATA cert	
156299	SATA air tester, use to determine contaminates in airline	
Other accessories		
59675	SATA dosenboy, to cut out can lids from cans up to 36 cm height	
165506	Air cap protectors (red) for SATAjet 3000 B, K, SATAjet 2000, all K3's and LP90, 5 pack	
165514	Air cap protectors (red) for SATAjet 100 B and SATAjet 1000 B, SATAjet 4000 B, 5 pack	
165522	Air cap protectors (red) for SATAminijet 3000, 5 pack	
139444	Air cap protector (black) for UV materials, (not shown), 5 pack	
TP-90S	SATAjet 90, each	
TP-90S5	SATAjet 90, 5 pack	
TP-MC	SATA KLC, MC-B, LM 2000, LM-92, each	
TP-MC5	SATA KLC, MC-B, LM 2000, LM-92, pack of 5	
TP-MINI	SATAminijet, minijet 2, minijet 3, each	
TP-MINI5	SATAminijet, minijet 2, minijet 3, pack of 5	
TP-INLET	Dan-Am inlet protector, each	
TP-INLET5	Dan-Am inlet protector, pack of 5	

Technical modifications and printing errors reserved

Additional spray gun accessories and equipment on page 148

Disassembly of nozzle set



1 First remove paint needle.

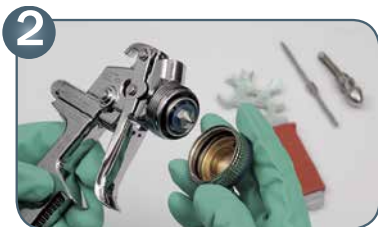

2 Followed by the cap.

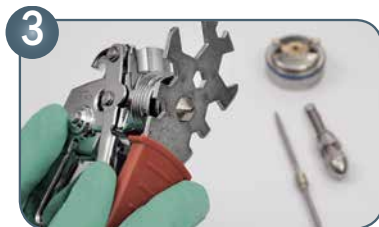

3 And finally, unscrew fluid tip with the ring spanner integrated in the universal spanner.

Cleaning and drying



1 Clean the material passage



2 Clean the spray gun body



3 Dry with blow gun

When cleaning the nozzle components, please make sure that metal parts of brushes do not damage the nozzle set. Ideally, please use specially designed SATA cleaning brushes and SATA nozzle cleaning needles to ensure optimum cleaning and maintenance of the nozzle set.

Cleaning of the nozzle set



When cleaning the nozzle components, please make sure that metal parts of brushes do not damage the nozzle set. Ideally, please use specially designed SATA cleaning brushes and SATA nozzle cleaning needles to ensure optimum cleaning and maintenance of the nozzle set.

Please watch our video at www.satausa.com/TV concerning "Cleaning and Maintenance of Spray Guns". Or simply order the cleaning brochure (Art. No. 158162) or the cleaning poster (Art. No. 158162P) for manual or gun washer, free of charge!

Assembly and Maintenance



Assembly of the fluid tip



Tighten fluid tip by hand using the universal spanner.



Assembly of the air cap



Grease paint needle around the needle packing area



Insert paint needle

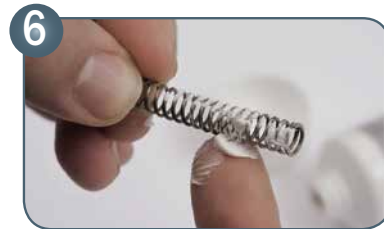

Grease and insert paint needle spring



Grease thread of material flow control screw









Install material flow control screw



Grease visible part of air piston rod

Cleaning accessories

162628	SATA care set, spray gun care bag with cleaning implements and spray gun grease	
48173	Tube with SATA high performance grease f. spray guns, silicone and acid-free, contents 100 g	
9894	SATA nozzle cleaning needles set of 3 x 12	
62174	Pack of 12 SATA nozzle cleaning needles	
64030	SATA cleaning set: 2 cleaning brushes and 12 cleaning needles	
6007	Cleaning brush (10x) for spray guns	
9209	Cleaning brush, double-sided (10) for spray guns	
158840	Cleaning brush, large (5x) for spray guns	

SATA Calculator Available

@ www.satausa.com

Services > Paint Advisor > Calculator

PSI to Bar
Bar to PSI



Inches to Millimeter
Millimeter to Inches



CFM to ML/Min
ML/Min to CFM



SATA calculator has six conversions.

Metric to Decimal Conversion Chart

0.15mm = .0059	1.0mm = .0394	1.9mm = .0748
0.2mm = .0078	1.1mm = .0433	2.0mm = .0787
0.25mm = .0098	1.2mm = .0472	2.1mm = .0827
0.35mm = .0138	1.3mm = .0512	2.2mm = .0866
0.5mm = .0197	1.4mm = .0551	2.3mm = .0906
0.6mm = .0236	1.5mm = .0591	2.4mm = .0945
0.7mm = .0276	1.6mm = .0630	2.5mm = .0984
0.8mm = .0315	1.7mm = .0669	3.0mm = .1181
0.9mm = .0354	1.8mm = .0709	5.0mm = .1969

Approximately 28.3 l/min = 1 cfm.	Approximately 1 Bar = 14.5 psi	DIN 4 Viscosity Cup Orifice 4mm = .1575
---	--------------------------------------	---

0.9463 liter = 1 qt	.03 liter = 1 oz.	2.54 cm = 1 inch	1 meter = 39.37 inches
------------------------	----------------------	---------------------	---------------------------

8 oz = 1 cup	16 oz = 1 pint	32 oz = 1 quart	128 oz = 1 gallon
-----------------	-------------------	--------------------	----------------------

Helpful Tips for Top Quality Paint Jobs

Spray pattern



Round spray uneven



Sickle spray pattern



Deformed spray pattern on one side



Split fan
(swallow-tail)



Material deposit too heavy in
fan pattern



Irregular or fluttering fan pattern

Cause and remedy

Middle air cap air passage dirty or deformed

Clean thoroughly or replace nozzle set if required

Air cap horn dirty or deformed

Clean horn air passages or replace nozzle set

Dirty or deformed holes in air cap horns

Clean nozzle with special cleaning kit or replace nozzle set

Too much thinner in material

Spray pressure too high

Fan width too wide

Atomization pressure too low – **increase pressure**

Viscosity too high – **add thinner to material**

Too much material – **use smaller nozzle set**

Fluid tip or needle loose – **tighten parts**

Paint cup plugged – **clean air vent hole** (lid vent)

Air distribution ring – **replace**

Cup Systems



SATA® RPS™ System



SATA RPS

Suitable for all paint materials! Please observe the recommendations of the paint manufacturers to choose the correct sieves (flat sieve 125 µ/200 µ and plug-in sieve 200 µ)

SATA RPS 0.3 | minijet

118299 SATA RPS 0.3 | minijet 125 µm flat sieve, 60-pk



118414 SATA RPS 0.3 | minijet 200 µm plug-in sieve, 60-pk



SATA RPS 0.3 | Standard sized guns

118281 SATA RPS 0.3 | 125 µm flat sieve, 60-pk



118406 SATA RPS 0.3 | 200 µm plug-in sieve, 60-pk



SATA RPS 0.6 |

125062 SATA RPS 0.6 | 125 µm flat sieve, 57-pk



125070 SATA RPS 0.6 | 200 µm plug-in sieve, 57-pk



151746 SATA RPS 0.6 | 200 µm flat sieve, 57-pk



SATA RPS 0.9 |

118471 SATA RPS 0.9 | 125 µm flat sieve, 40-pk



118489 SATA RPS 0.9 | 200 µm plug-in sieve, 40-pk



151720 SATA RPS 0.9 | 200 µm flat sieve, 40-pk



SATA RPS 0.6 | UV

139451 SATA RPS UV 0.6 | 125 µm flat sieve, 57-pk



139469 SATA RPS UV 0.6 | 200 µm plug-in sieve, 57-pk



Technical modifications and printing errors reserved

Spare Parts SATA® RPS™

Order No./Desc.
131961
80-pk spare lids for 0.6 l and 0.9 l cups
131979
100-pk 125µ blue flat sieves for 0.6 l and 0.9 l cups
131987
100-pk 200µ green plug-in sieves for all sizes
144964
100-pk 200µ green flat sieves for 0.6 l and 0.9 l cups
160606
60-pk 125µ blue flat sieves for 0.3 l cups
167908
90-pk spare lids for 0.3 l cups for standard guns

SATA RPS 0,3 l Standard

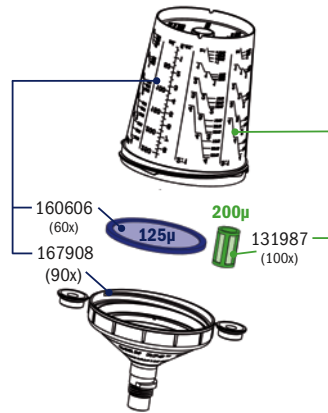

SATA RPS 0,3 l minijet

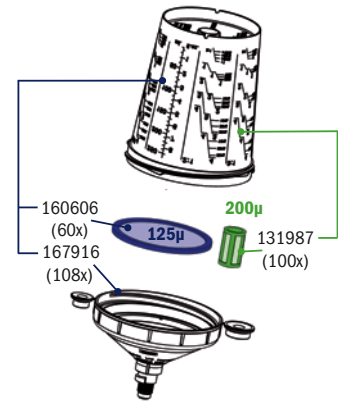



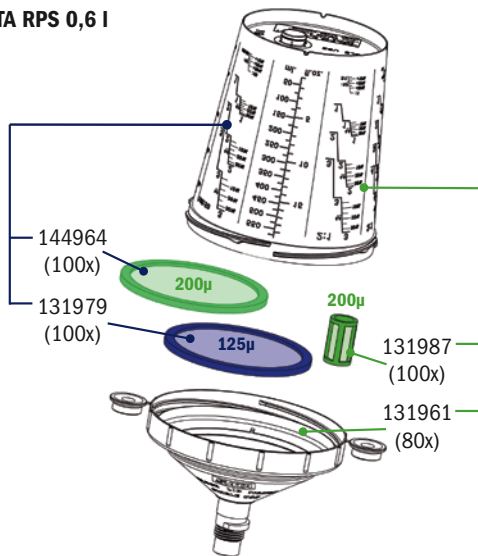



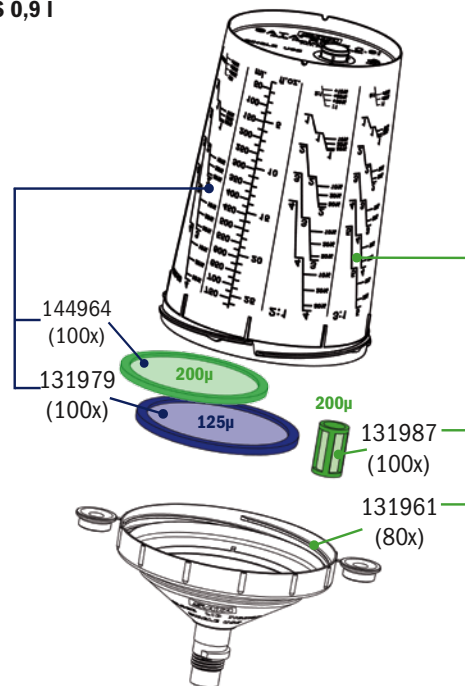



SATA RPS 0,6 l



SATA RPS 0,9 l















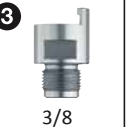

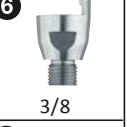

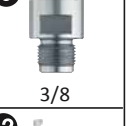
Accessories for SATA® RPS™

Accessories for SATA RPS		
40188	SATA universal gravity gun holder for gravity flow cups	
9886	SATA wall mounted gravity gun holder	
127852	Cleaning solution bottle 1.0 l	
127860	Pressure pump spray bottle, 1.0 l	
127845	RPS 6-pack cup carrier	
139444	UV nozzle protectors, 5-pk	
165399	SATA RPS mix lid w/ 50 lids for RPS 0.6 l and 0.9 l (allows for stacking RPS)	
173435 117051	Shaker ring for the 0.03 l Shaker ring for 0.06 l and 0.09 l	
170845	Mixing stick, suitable for all waterborne and solvent borne paints	
144840	Rps Depot Storage rack to hold up to three RPS cup boxes (RPS cups not included)	

Technical modifications and printing errors reserved



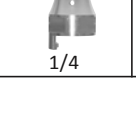





SATA® RPS™ Adapter





Manufacturer	Spray Gun	Adapter	Part No.
SATA	SATAjet 2000 HVLP, RP w/o QCC	2	125237
	SATAjet LM 2000 HVLP/RP, SATAjet 90	2	125237
	SATAjet KLC HVLP/RP, KLC P	2	125237
	SATAjet B, NR 92, NR 95 HVLP	1	125211
	SATAjet LM B 92	7	133595
	SATAminijet, minijet 2, 3, 4	10	135798
	SATAjet 1000 H	16	188292
	SATAminijet 1000 H	17	188318
Binks	MG-1	3	125252
Accuspray	Isaac	11	134080
Airgunsa	AZ40 THE	4	125278
Asturo	OM Green	5	125294
3M/Graco	3M PPS	6	126326
DeVilbiss	PRI, GTI, GTI Pro, GFG, GFV, GFHV 510, Tekna, CVI	3	125252
	SRI	15	164608
Starting Line/	HLVP Spray Gun	13	150136
Finish Line	Mini Spray Gun	14	150151
Emininet	E13	4	125278
IWATA	W 400, WR 400, LPA 94	1	125211
	VXL Primer Gun, LPH 400, LPH 440	1	125211
	LPH 80	19	193276
	LS-400 (Super Nova), W 300, LPH 300	4	125278
	LPH100-LVG	12	147272
Kremlin	M 21 G	4	125278
Optima	800, 900	8	133827
Sagola	475 Mini-Gun	10	135798
	403 G, 433 G, 434 G, 444 G, 450 G	7	133595
	4100 G, 4200 G, 4300	7	133595
	4400	1	125211
	4400/4500 Xtreme	18	188664
Sharpe	GT1, Platinum, Titanium, Cobalt, SGF 98, Razor primer	9	135111
	Finex FX 300	8	133827
Walcom	FX GEO, FX HVLP	5	125294



RPS Adapter		
 16 x 1.5	 16 x 1.5	 3/8
 1/4	 12 x 1	 3/8
 12 x 1.5	 3/8	 3/8
 10 x 1	 3/8	 1/4
 16 x 1.5	 11 x 1	 7/16
 3/8	 1/4	 18 x 1
 1/8	for updated adapter selections please visit www.satausa.com > encyclopedia > spray gun adapters	

Technical modifications and printing errors reserved

SATA® Gravity and Siphon Cups for Spray Guns

Gravity flow cup						
Gun type		SATAjet 4000 B, jet 3000 B, jet 1000 B, jet 100 B, jet 2000, jet RP, KLC, LM 2000 B	SATAjet B, jet GR, jet NR 95	SATAminijet 3000 B, minijet 1 - 4, jet 20 B	SATAjet 20 B Dekor 2000	Lid
Capacity	Order No.					
Reusable Plastic cup						
2.2 oz. (63 ml)	15669			 use with adapter part no. 129346		15909
2.2 oz. (63 ml)	153551			 with adapter No.129346		15909
3.0 oz. (85ml) QCC	165142	 use with adapter part no. 169326				95448
4.2 oz., (0.125 l) QCC	125443					95448
0.3 l	128470					121293
0.6 l	49379					49395
0.6 l	27243					49395

Gravity flow cup					
Gun type		SATAjet 4000 B, jet 3000 B, jet 1000 B, jet 100 B, jet 2000, jet RP, KLC, LM 2000 B	SATAjet B, jet GR, jet NR 95	SATAminijet 3000 B, minijet 1 - 4, jet 20 B	Lid
Capacity	Order No.				
Reusable aluminum cup					
0.15 l	125948				64022 Pk of 3 64022-10 Pk of 10
0.75 l	6601				71555 Pk of 3 71555-10 Pk of 10
0.75 l	137729				
1.0 l	46631				
1.0 l	96685				

Aluminum Siphon cup					
Gun type		SATAjet 1000 H, Satajet H, LM 2000 H, GR/H-92, LM/H92 std	SATAjet/H NR-92 SATAjet/H NR-95		
Capacity	Order No.				
Reusable Aluminum Siphon cup					
1.0 l	17855				

Spare Parts

SATA® Aluminum and PVC Gravity Flow Cups for Spray Guns



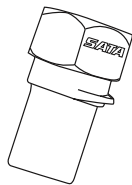
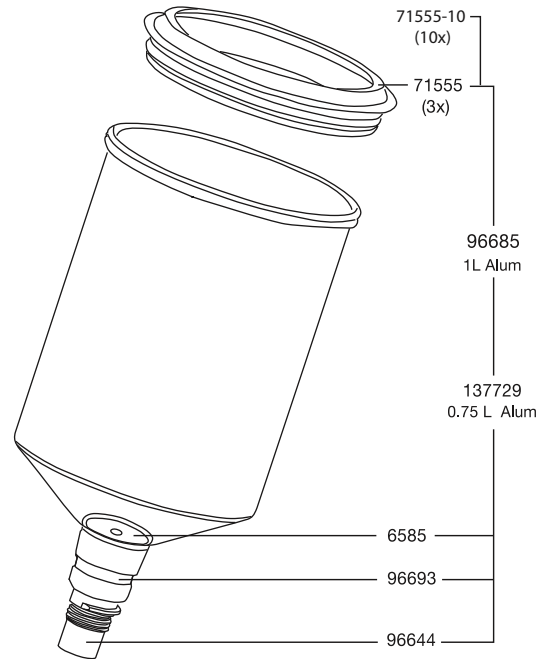
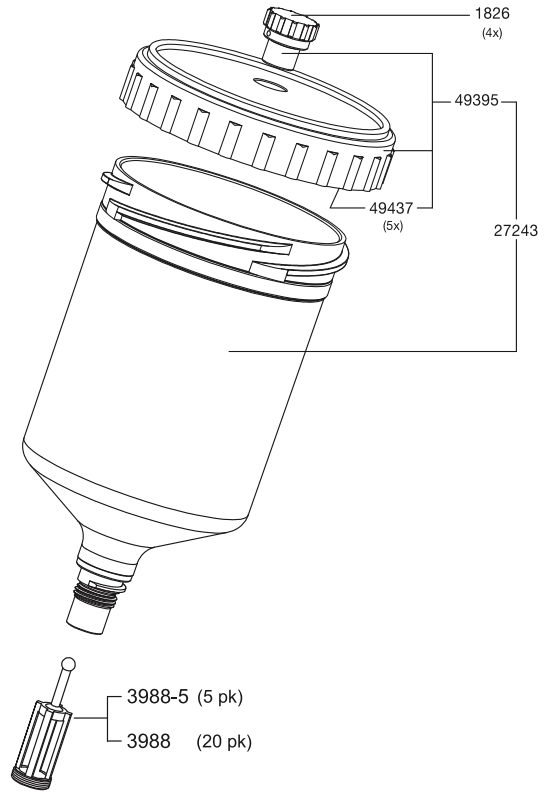

Order No./Desc.	
1826	Non-drip device, pk of 4
3988	Sieve, pk of 20
3988-5	Sieve, pk of 5
6585	Insert, aluminum cup
27243	Cup, 0.6L QCC plastic, cpl
49395	Lid, 0.6L plastic
49437	Cup Lid Drip Ring, 0.6L, pk of 5
71555	Lid, plastic, pk of 3
96644	Nipple, QCC aluminum cup
96685	Cup, 1L QCC aluminum, cpl
96693	Ring, QCC marking
96719	Adapter, QCC to PPS cup
96875	Inner cup seal
129346	Adapter, QCC to PPS cup, SATAMinijet 3000 B
137729	Cup, 0.75 L alum, cpl







96719 QCC adapter, PPS Full size

Technical modifications and printing errors reserved

SATA® Glass Siphon Cups and Cup Adapters

Glass cups				
Gun type		SATAMinijet 2, 3, 4 SATAMinijet 3000 B	SATA dekor SATAjet 20 B	
Capacity	Order No.			
Side mount glass siphon cups				
25 ml plug-in cup, each	16295	X	X	
25 ml plug-in cup, pk of 5	53033	X	X	
25 ml plug-in cup, pk of 5 w/ plug-in adapter	125963	X	X	
25 ml blind cup, each	16386	X	X	
25 ml blind cup, pk of 5	58164	X	X	

Cup Adapters		
96719	QCC cup adapter for PPS cup, full size guns	
125955	SATAMinijet or SATAjet 20 B (dekor) cup adapter, glass siphon cups	
129346	2.2 fl oz. QCC cup adapter for SATAMinijet 3000 B	
169326	3.0 fl. oz. QCC cup adapter for full size SATA guns	

Technical modifications and printing errors reserved

SATA® BVD

SATA BVD adaption kit

25775	SATA BVD 0.75 aluminum pressure gravity cup for SATA spray guns - male and QC threads
57505	SATA BVD 0.75 aluminum pressure gravity cup for SATA spray guns - female thread

Art. No./Descr.	
8268	Sealing ring
20438	Safety pressure relief valve BVD
20461	Plastic air hose for BVD and agitator cup
21014	Aluminium lid, cpl.
21048	Pressurised cup with lid
25577	Pressurised cup with lid
53777*	Air connection for aluminium lid
54049	Sealing ring (4x)
65920	Control fittings, complete, for BVD pressurised cup connection kit (GR and LM)
70664	Anti-drip device (10x)
83493	Connection for pressurised cup, cpl.
83501	Air hose cpl. w. pressurised cup connection, for SATA Spray-Master
120816	Pressure release screws (2x)
133983	Air connection piece G1/4 male thread
* please also order 8268	



(gun not included)

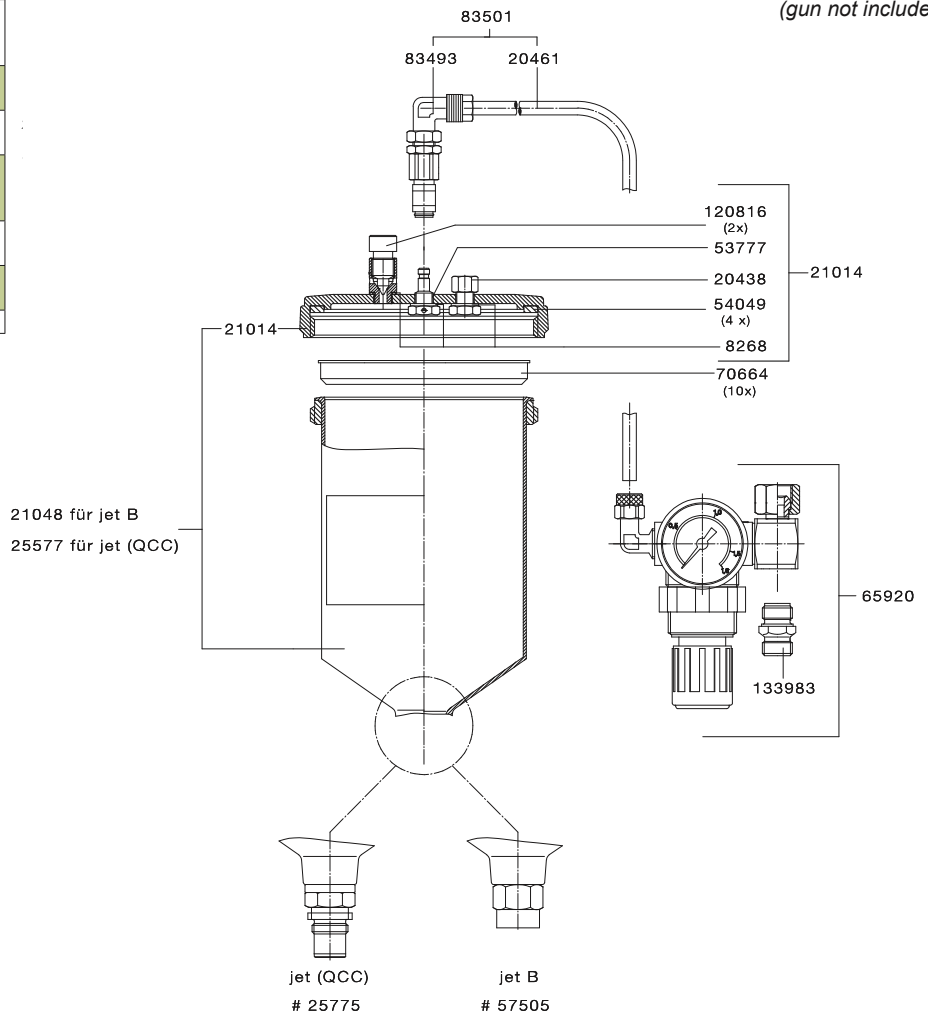

Technical modifications and printing errors reserved

SATA® Agitator Cup

SATA agitator cup

29926 SATA conversion kit for agitator cups for SATAjet 4000 B, 3000 B, 2000 B, 1000 series, LM2000 series spray guns

Art. No./Descr.
1503 Countersunk screw M4 x 8 DIN 965, stainless steel, for micrometer and round/flat spray control
1826 Anti-drip device (4x)
2188 Spindle, complete, for regulation valve
9951 SATA agitator-cup for SATAjet B and GR/B-92 (supplementary equipment)
20461 Plastic air hose for BVD and agitator cup
21055 Agitating vane for agitator cup, cpl
21063 Driving wing, cpl. with screw
21071 Gasket agitating vane, agitator cup
29926 SATA conversion kit for agitator cup for SATAjet 3000, jet 2000 HVLP, Jet RP, jet 1000, LM 2000
44735 Countersunk screw M 2.5 x 5 DIN 965 SATAMinijet 3000 B HVLP, minijet 4 HVLP
44743 Control knob
44792 Spindle complete for SATAMinijet
53785 Angle screw socket, LCN-1/8-PL-4, f. SATA NAD and BVD
53793 Coupling with inner thread G 1/8 for SATA BVD and Spray-Master
54049 Sealing ring (4x)
65557 Control knob

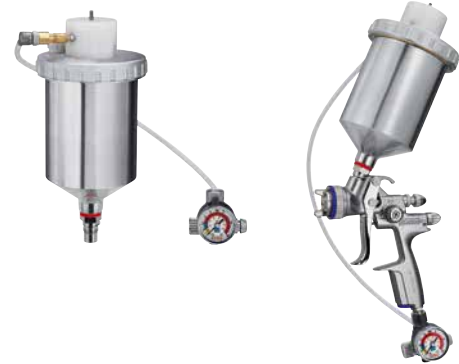

(gun not included)

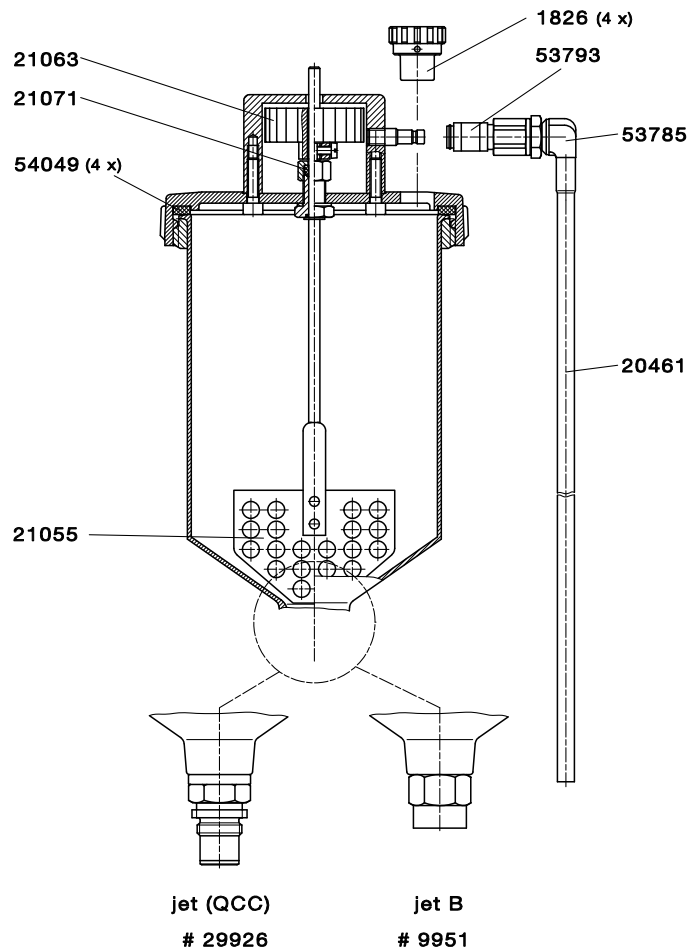

Breathing Protection



Breathing Protection with Activated Charcoal Belt Unit

Air-fed full hood for use with double stage filter regulators eg: SATA 444



Basic Version w/ Activated Charcoal Belt Unit

Hood

SATA vision 2000 hood with PVC breathing hose connection



36384
Hood and filter

Belt Unit

Activated Charcoal Belt Unit



Required Accessories

Non-gassing air hose connection from filter to belt
Various sizes available, see page 161

CO Monitors page 146

See page 98

Optional Accessories for Breathing Protection with or without Activated Charcoal Belt Unit.

Optional Accessories

Breathing air warmer

Infinitely adjustable breathing air warmer
Order No. 61242



Breathing air humidifier

Breathing air humidification for a comfortable breathing climate
Order No. 89 086



Breathing Protection with Industrial Belt Valve



Air-fed full hood for use with triple stage filter regulators eg: SATA 484



See page 102

Basic Version w/ Industrial Belt Valve

Hood

SATA vision 2000 hood with PVC breathing hose connection



60707 Hood and belt unit

Belt Unit

Belt unit with industrial valve



Required Accessories

Non-gassing air hose connection from filter to belt
Various sizes available, see page 161

CO Monitors page 146

Basic Version w/ Activated Charcoal Belt Unit

Mask

SATA air star C half mask with PVC breathing hose connection



137547 Mask and filter

Belt Unit

Activated Charcoal Belt Unit



Basic Version w/ Industrial Belt Valve

Mask

SATA air star C half mask with PVC breathing hose connection



137745 Mask and belt unit

Belt Unit

Belt unit with industrial valve



Required Accessories

Non-gassing air hose connection from filter to belt
Various sizes available, see page 161

CO Monitors page 146

SATA air star C breathing protection half mask



See page 100, 104

SATA® vision™ 2000 with Activated Charcoal Belt Unit







Painting may generate excessive levels of overspray and solvent vapors. Some solvents cause poisonous toxic effects as they are absorbed into the bloodstream. Isocyanate hardeners are a specifically hazardous substance. The Type C continuous flow supplied air respirator with a full face shield provides complete protection for the eyes, skin and respiratory system..

The SATA vision 2000 NIOSH approval number is TC-19C-211. NIOSH approved respirators must be supplied with Type 1 Grade D air within the approved pressure range at the point of attachment of the respirator to the air delivery system. The activated charcoal belt unit is an auxiliary filter. Breathing air is filtered through activated charcoal. The activated charcoal purifies the air and removes any odor or hydrocarbon vapor. Air-flow is controlled with a throttle valve. A pressure gauge is mounted on the belt unit to visually monitor correct pressure setting.



SATA vision 2000

Technical Data	Require operating pressure: 4.0 bar / 58 psi
	Require minimum air volume flow: 170 l/min / 6.2-11.3 cfm at 60-87 psi

Available versions

36384	The vision 2000 hood is a type C continuous flow supplied air respirator with full face shield. It is very comfortable to wear with an adjustable headband. Painters with reasonable beard length, mustaches or eyeglasses will appreciate the full hood protection with wide field of vision and single pane, non-glare anti-static visor. The hood is hygienic due to easily replaced linings and sweatband. It also features a tip-up visor making it unnecessary for the painter to remove the hood between coatings.	
	NIOSH Approved	
51854	SATA vision 2000 full hood respirator only.	
37200	SATA activated charcoal absorber belt unit for SATA vision 2000 full hood	
52670	Full hood respirator with closed visor and full neck shield Currently under review for EPA approval (NIOSH), please check for latest update.	

Accessories

61242	SATA air warmer with air micrometer for SATA respirators	
89086	SATA top air breathing humidifier	

Spare Parts SATA® vision™ 2000

vision 2000 Hood

Part No. 51854

Order No./Desc.	
10330	Sweat band, artificial leather, pk of 10
13854	Air silencer
21840	Visor pins, pk of 6
27821	Headband adjusting nut
30270	Hose clamp
35050	Visor tear off sheet, pk of 50
35100	Visor tear off sheet, pk of 100
35659	Visor tear off sheet, pk of 5
35675	Visor tear off sheet, pk of 25
36301	Visor tear off sheet, pk of 1000
47571	Sweat band, artificial leather, ea
51854	vision 2000 hood, complete
56184	Foam sleeve, only
56192	Air hose with foam sleeve
56788	Hood cloth, anti-static
61226	Headband, natural sheep leather, ea.
69658	White lining, pk of 20
75358	SATA hood cleaner, pk of 10
76299	Headband foam strip, w/adhesive
82594	Head piece with velcro
89243	Adjusting assembly, headband
89250	Headband, complete
89268	Nut assembly, headband
89268P	Pivot, headband adjusting, pk of 2
89276	Visor frame, complete
138735	Pivot, headband adjusting, pk of 10
164335	Sweat band, natural calf leather

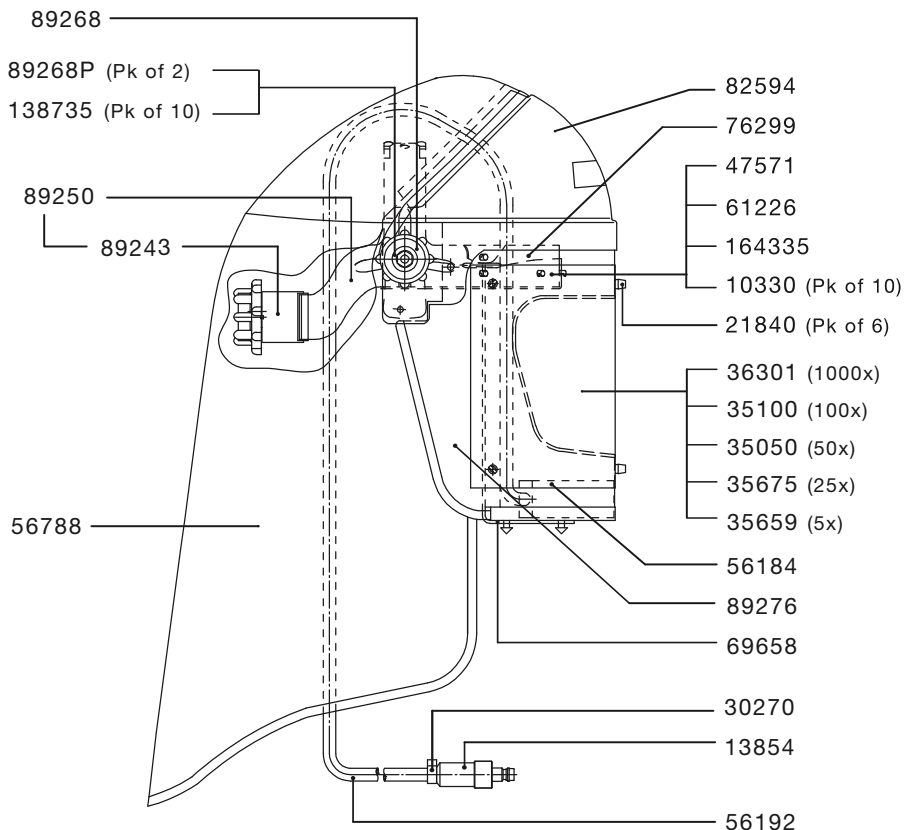

Charcoal Belt Unit, vision 2000

Part No. 37200

Order No./Desc.	
13904	Charcoal filter cartridge
13920	Waist belt only, no cushion
15412	Belt unit support straps
22947	O ring, housing
25171	Regulating valve, vision 2000
37200	Belt unit, complete vision 2000
37523	Gauge, vision 2000
48934	Air micrometer w/o gauge
49726	Protective filter cover
53934	Quick coupling
53942	Nipple
66852	Filter cover
149872	Belt cushion only

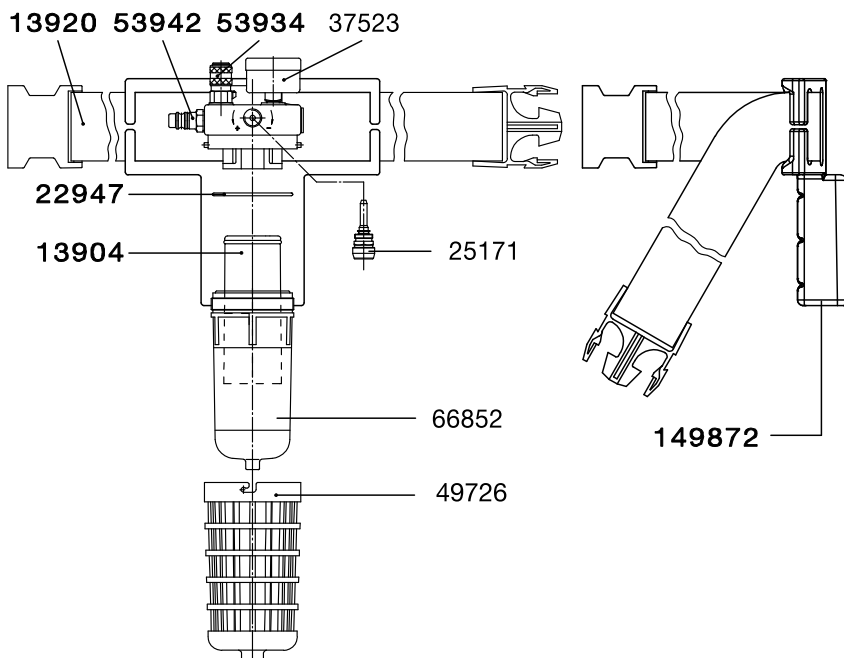

Technical modifications and printing errors reserved

SATA® air star C™ with Activated Charcoal Belt Unit



The SATA air star C™ half mask NIOSH approval number TC-19C-210. NIOSH approved respirators must be supplied with Type 1 Grade D air within the approved pressure range at the point of attachment of the respirator to the air delivery system. The activated charcoal belt unit is an auxiliary filter. Breathing air is filtered through activated charcoal. The activated charcoal purifies the air and removes any odor or hydrocarbon vapor. A built-in indicator strip changes color to a dark blue as the activated charcoal becomes saturated with oil or moisture. Airflow is regulated with a throttle valve. An airflow gauge is mounted on the belt unit to visually monitor correct airflow setting. The SATA air star C does not have to be form fit.

SATA air star C

Technical Data

Required operating pressure: 58 psi

Require minimum air volume flow: 5 cfm

Maximum air volume flow: 11 cfm

Available versions

137547

The SATA air star C is a ventilated half-mask with adjustable continuous fresh-air supply. Body of mask made of natural rubber with anatomic formed sealing frame and matching nose seating. Built in exhausting valve. The SATA air star C half mask provides excellent vision with no internal heat buildup or moisture. The SATA air star C half mask offers a perfect face fit with four-point fixed head straps for seating the mask safely. Painters should bear in mind that half masks do not provide complete protection from dangerous Isocyanates that can be absorbed through the eyes and facial skin.



NIOSH Approved



137653

SATA air star C respirator w/ breathing hose



37192

Activated charcoal belt valve for air star C



Accessories

61242

SATA air warmer with air micrometer for SATA respirators



89086

SATA top air breathing humidifier



Spare Parts SATA® air star C™

SATA Air Star C half mask with air hose

Part Number 137653

Order No./Desc.	
120469	Hose assembly, complete
120477	Air distribution foam, Pack of 2
134254	Head straps
134270	5-pk exhalation diaphragms + 10-pk inhalation diaphragms
137612	2-pk connections

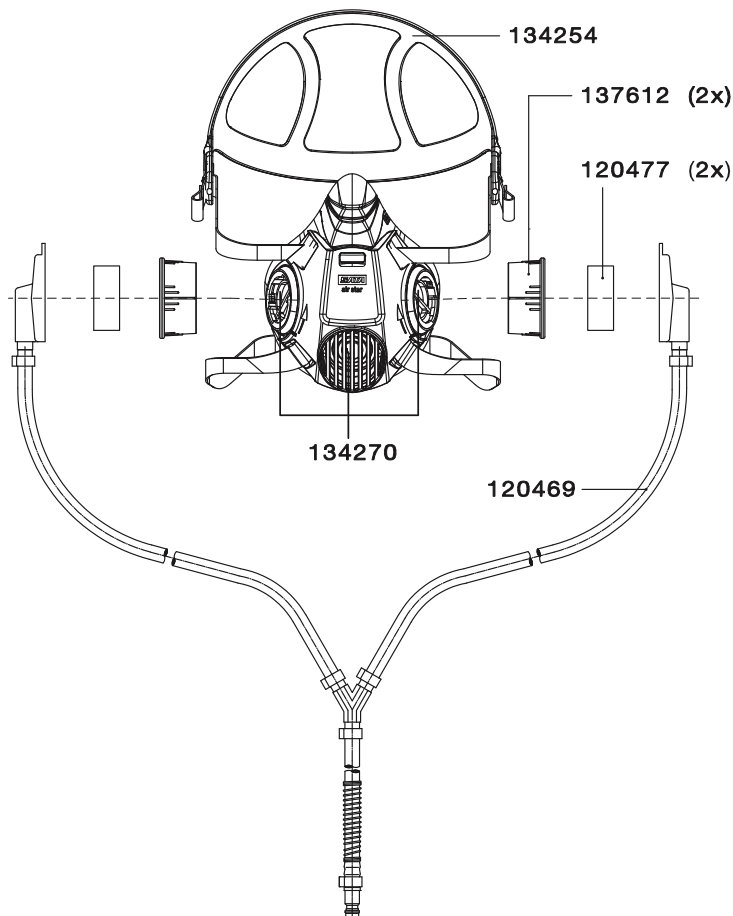

Charcoal Filter, Half Mask

Part Number 37192

Order No./Desc.	
13904	Charcoal filter cartridge
13920	Waist belt
15412	Belt unit support straps
22947	O ring, housing
25155	Regulating valve
37192	Belt unit, complete half mask
37507	Gauge, air pressure, HM belt unit
49726	Cover, protective filter
53942	Nipple, 1/4 male hi-flow
55640	52" Paint whip hose
67074	Filter cover
75176	Quick coupling, half mask
149872	Belt cushion only

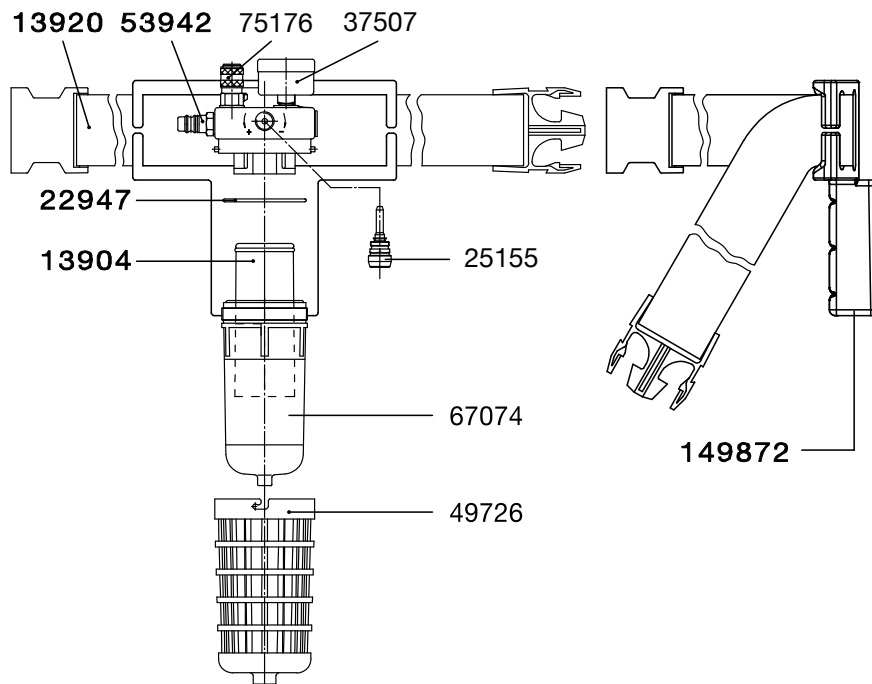

Technical modifications and printing errors reserved

SATA® vision™ 2000 with Industrial Belt Valve



Air-fed full hood for the use with triple-stage filter regulators
e.g. SATA filter 484

SATA vision 2000

Technical Data

Require operating pressure: 58 psi

Require minimum air volume flow: 6.2-11.3 cfm at 60-87 psi

Available versions

60707

The vision 2000 hood is a type C continuous flow supplied air respirator with full face shield. It is very comfortable to wear with an adjustable headband. Painters with reasonable beard length, mustaches or eyeglasses will appreciate the full hood protection with wide field of vision and single pane, non-glare anti-static visor. The hood is hygienic due to easily replaced linings and sweatband. It also features a tip-up visor making it unnecessary for the painter to remove the hood between coatings.



NIOSH Approved



51854

SATA vision 2000 full hood respirator only.



61002

SATA industrial belt valve for full hood



52670

Full hood respirator with closed visor and full neck shield



54825

Full hood respirator with cut-visor and full neck shield



Accessories

61242

SATA air warmer with air micrometer for SATA respirators



89086

SATA top air breathing humidifier



Technical modifications and printing errors reserved

Spare Parts SATA® vision™ 2000 and Ind. Belt Valve

vision 2000 Part No. 51854

Order No./Desc.	
10330	Sweat band, artificial leather, pk of 10
13854	Air silencer
21840	Visor pins, pk of 6
27821	Headband adjusting nut
30270	Hose clamp
35050	Visor tear off sheet, pk of 50
35100	Visor tear off sheet, pk of 100
35659	Visor tear off sheet, pk of 5
35675	Visor tear off sheet, pk of 25
36301	Visor tear off sheet, pk of 1000
47571	Sweat band, artificial leather, ea
51854	vision 2000 hood, complete
56184	Foam sleeve, only
56192	Air hose with foam sleeve
56788	Hood cloth, anti-static
61226	Headband, natural sheep leather, ea.
69658	White lining, pk of 20
75358	SATA hood cleaner, pk of 10
76299	Headband foam strip, w/ adhesive
82594	Head piece with velcro
89243	Adjusting assembly, headband
89250	Headband, complete
89268	Nut assembly, headband
89268P	Pivot, headband adjusting, pk of 2
89276	Visor frame, complete
138735	Pivot, headband adjusting, pk of 10
164335	Sweat band, natural calf leather

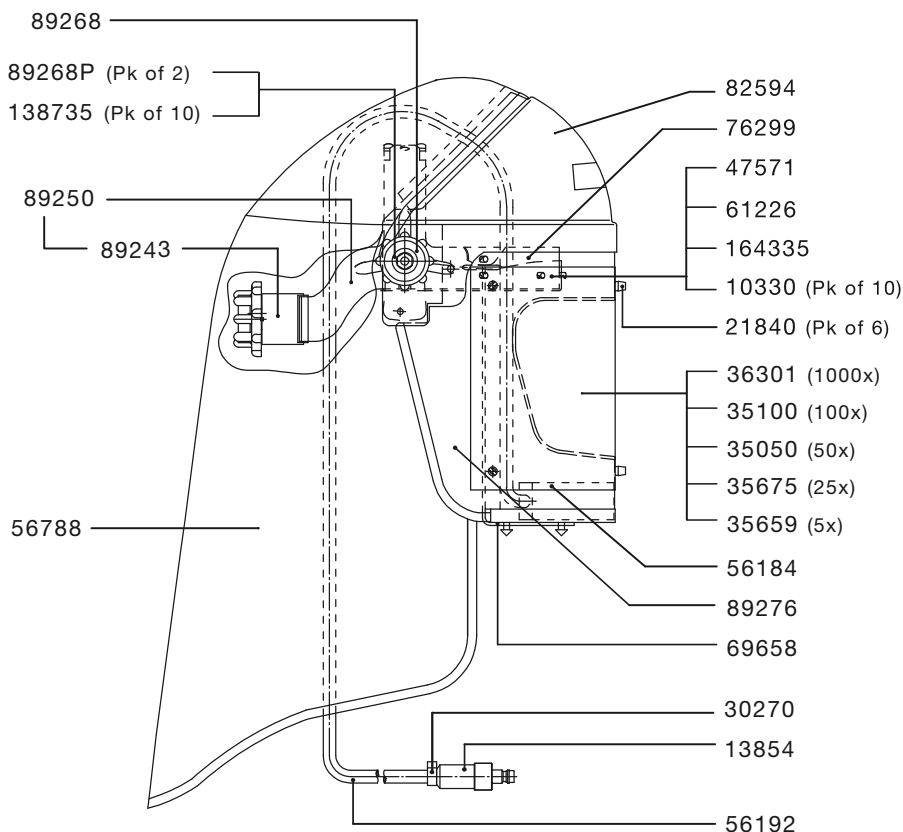

Industrial belt valve Part No. 61002

Order No./Desc.	
1503	Air control screw
13656	Female threaded nipple
13920	Waist belt
51656	T fitting, (supplied separately)
53934	Nipple, 1/4 male
54221	Fan control
54908	L Bracket
61002	Belt valve complete, vision 2000
65557	Knob, fan control
149872	Belt cushion only, foam

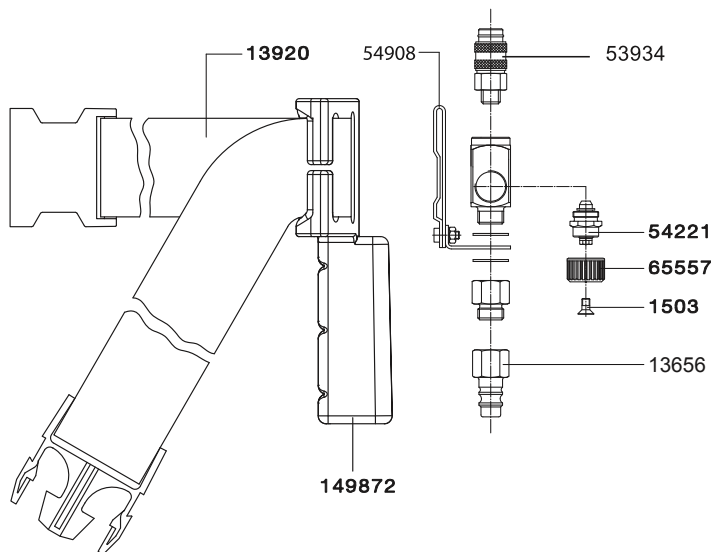

Technical modifications and printing errors reserved

SATA® air star C™ with Industrial Belt Valve



Air-fed half mask for the use with triple-stage filter regulators e.g. SATA filter 484

SATA air star C

Technical Data

Required operating pressure: 58 psi

Require minimum air volume flow: 5 cfm

Maximum air volume flow: 11 cfm

Available versions

137745

The SATA air star C is a NIOSH approved ventilated half-mask with adjustable continuous fresh-air supply. Body of mask made of natural rubber with anatomic formed sealing frame and matching nose seating. Built in exhausting valve. The SATA air star C half mask provides excellent vision with no internal heat buildup or moisture. The SATA air star C half mask offers a perfect face fit with four-point fixed head straps for seating the mask safely. Painters should bear in mind that half masks do not provide complete protection from dangerous Isocyanates that can be absorbed through the eyes and facial skin.

SATA air star C does not need to be form fit.

NIOSH Approved



137653

SATA air star C respirator with breathing hose



61002

SATA industrial belt valve for half mask



Accessories

61242

SATA air warmer with air micrometer for SATA respirators



89086

SATA top air breathing humidifier



Spare Parts SATA® air star C™ and Ind. Belt Valve

SATA Air Star C half mask with air hose Part Number 137653

Order No./Desc.	
120469	Hose assembly, complete
120477	Air distribution foam, pack of 2
134254	Head straps
134270	5-pk exhalation diaphragms + 10-pk inhalation diaphragms
137612	2-pk connections

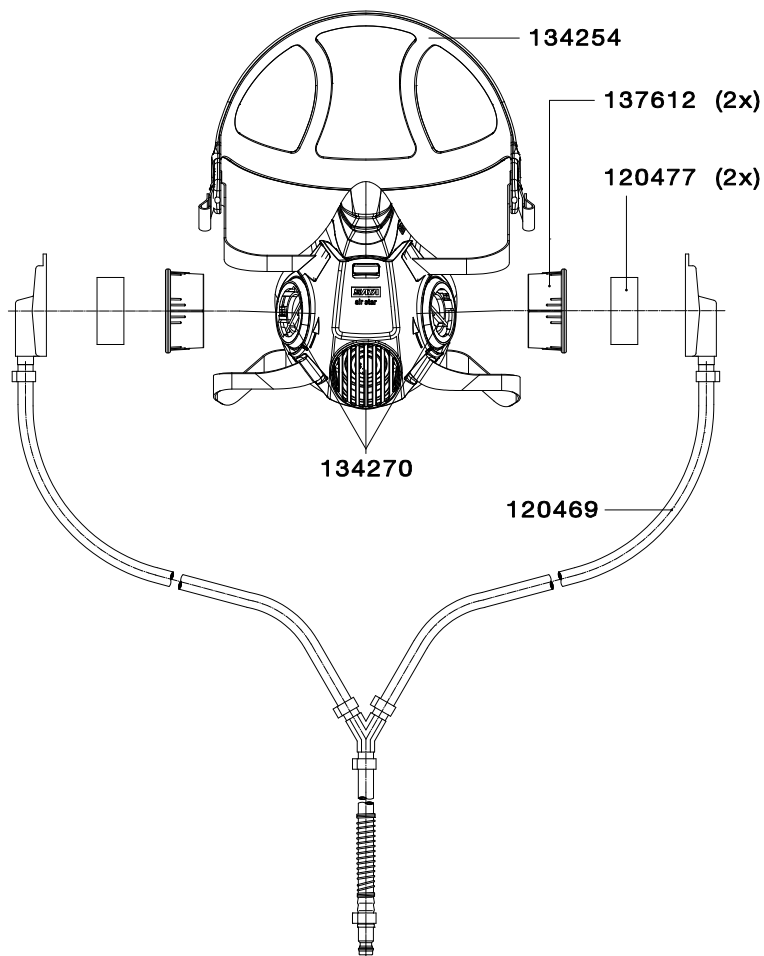





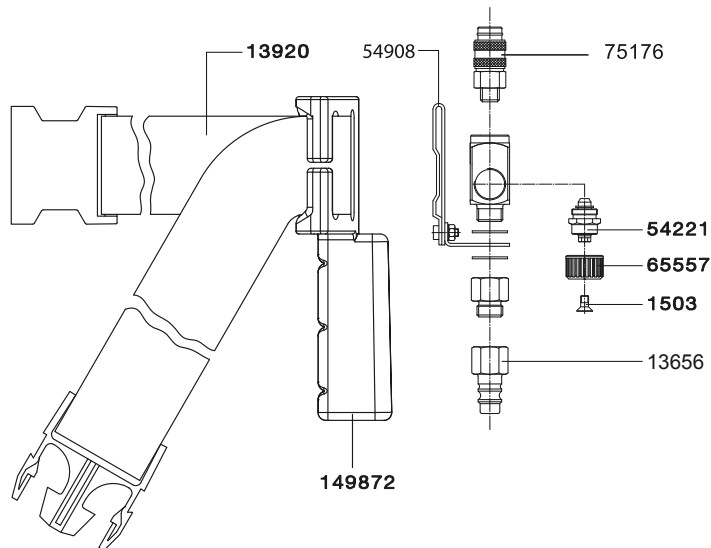





Industrial belt valve Part No. 138362

Order No./Desc.	
1503	Air control screw
13656	Female threaded nipple
13920	Waist belt
51656	T fitting, (supplied separately)
53934	Nipple, 1/4 male
54221	Fan control
54908	L Bracket
65557	Knob, fan control
66852	Filter cover
138362	Belt valve complete, half mask
149872	Belt cushion only, foam



Technical modifications and printing errors reserved

Accessories for SATA vision 2000/SATA air star C

Accessories for Belt Units		
13904	Activated charcoal filter cartridge for both full and half mask belt units. To be replaced every 3 months	
15412	Belt unit support straps, suspenders	
Accessories for all supplied air respirators		
89086	SATA top air breathing humidifier	
81158	Complete module for SATA top air	
61242	SATA air warmer with air micrometer for SATA respirators	
Cleaning Cloths		
75358	10-pk disinfecting tissues for SATA respirators	
Accessories for SATA vision 2000		
56762	Hood cloth only, gray industrial, for SATA vision 2000, with neck and chest protection	
35659	Tear off visor sheets, vision 2000, pack of 5	
35675	Tear off visor sheets, vision 2000, pack of 25	
35050	Tear off visor sheets, vision 2000, pack of 50	
35100	Tear off visor sheets, vision 2000, pack of 100	
36301	Tear off visor sheets, vision 2000, pack of 1000	
69658	Hygienic hood lining, vision 2000	
60226	Sweat band, natural leather (sheep), vision 2000	
164335	Sweat band, natural leather (calf), vision 2000	
47571	Sweat band, natural leather (sheep), vision 2000	
10330	Sweat band, natural leather (sheep), vision 2000, pack of 10	

Technical modifications and printing errors reserved

Spare Parts SATA® top air™

SATA top air, 2011

Order No./Desc.	
24505	Safety quick coupling
24612	Nipple
24620	Head gasket
24919	O ring, module
24950	Safety valve, complete
46169	Threaded nipple
53975	Hose clamp, 10.5
63214	Screw, filling cap
70789	O ring, filling cap
72611	Valve, complete
81158	Module, complete
82917	Air hose
86777	Head
86785	Receptacle
97311	Hose, PVC (cut to length)
163535	Holder
163543	Container with acme thread
176420	O-ring

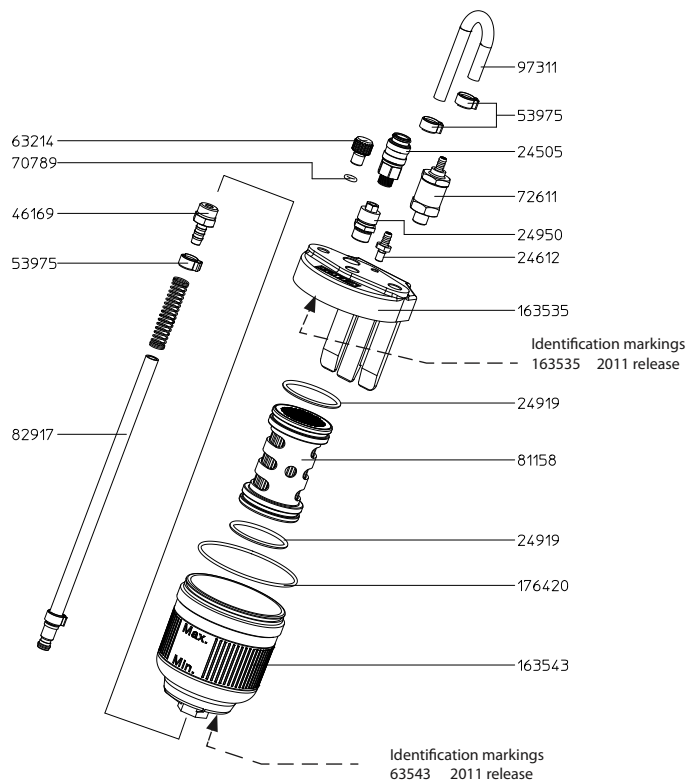

SATA top air, pre 2011

All parts not listed are common to the new version

Order No./Desc.	
24620	Head gasket
70789	O ring, filling cap
82917	Air Hose
86777	Head
86785	Receptacle NLA

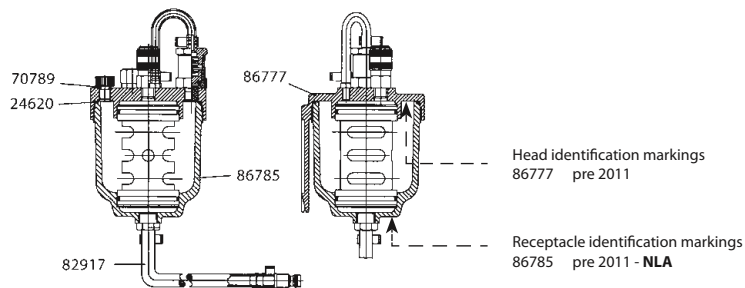

SATA air warmer

New and old version

Order No./Desc.	
1503	Screw, fan control
11551	O Ring
29413	Stainless steel nipple
53934	Safety quick coupling
61242	Air warmer with adjusting valve
65557	Knob, fan control

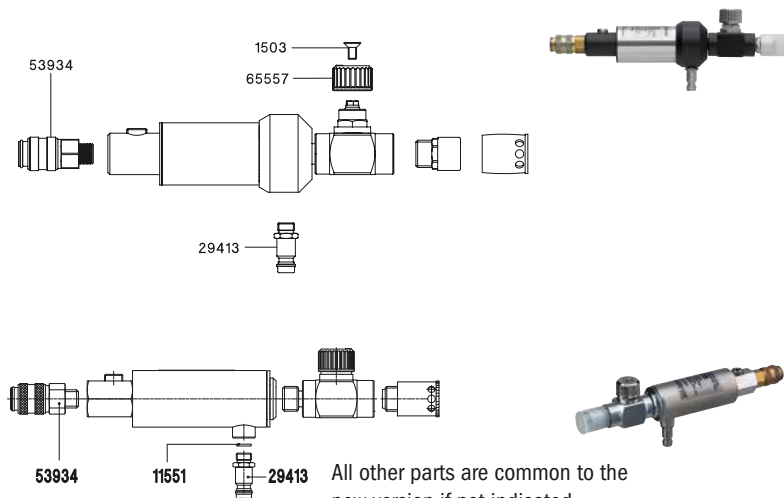



All other parts are common to the new version if not indicated

Technical modifications and printing errors reserved



SATA® air star F™



Filtering mask for short usage periods during small paint jobs

SATA air star F		
134353	SATA air star F, filter A2:P3 R D, 2 pre-filter holders and 10 pre-filters	
134288	SATA air star F, filter A2:P3 R D, 2 pre-filter holders and 10 pre-filters with hygiene box	

Accessories		
75358	10-pk disinfecting tissues for SATA respirators	

Spare Parts for SATA air star F		
134262	10-pk pre-filters for SATA air star F	
134239	50-pk pre-filters for SATA air star F	
134296	1 pair special filter A2:P3 R D for SATA air star F	
134312	3 pair special filter A2:P3 R D for SATA air star F	
134304	6 pair special filter A2:P3 R D for SATA air star F	
134247	2 pre-filter holders (red) and 10 pre-filters for SATA air star F	

Technical modifications and printing errors reserved

Spare Parts SATA® air star F™

Order No./Desc.
134239
50-pk pre-filters
134247
2 pre-filter holders (red) and 10 pre-filters
134254
Head straps
134262
10-pk pre-filters
134270
5-pk exhalation diaphragms, 10-pk inhalation diaphragms
134296
1 pair special filter A2:P3 R D
134304
6 pair special filter A2:P3 R D
134312
3 pair special filter A2:P3 R D

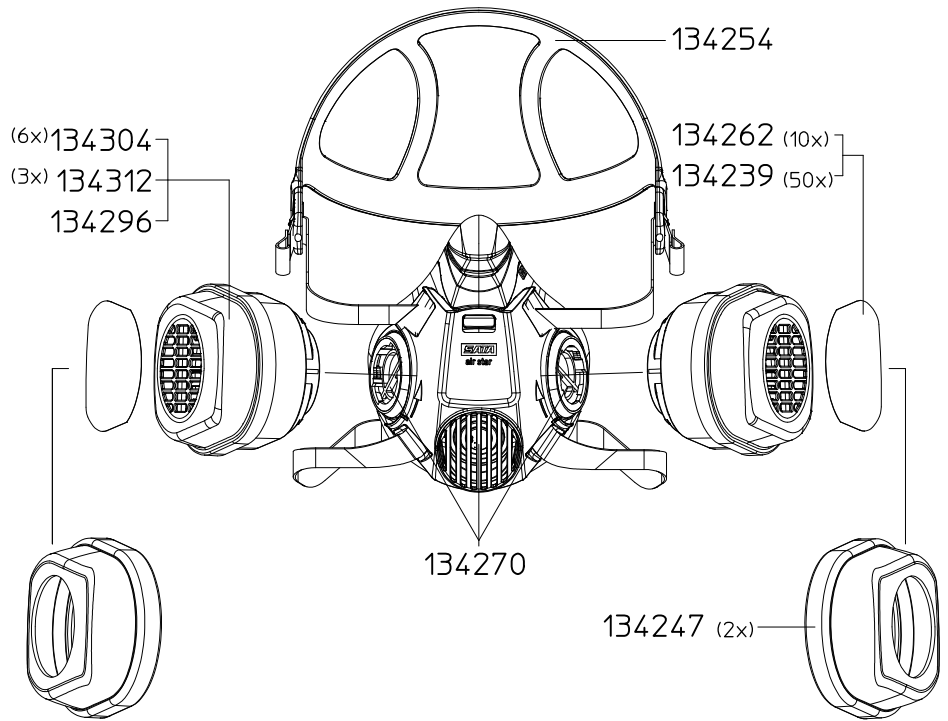

Technical modifications and printing errors reserved

Filtration



SATA® filter 414™/ 424™/ 434™/ 464™

SATA filter 414/424/434/464

Technical Data	
	Air inlet: G1/2 i
	Air outlet: G 1/4 a
	Max. inlet operating pressure: 15.0 bar / 217 psi
	Max. outlet operating pressure: 10.0 bar / 145 psi
	Air flow at 6.0 bar: 3,600 NI/min / 129 cfm @ 90 psi
	Max. ambient temperature: 248° F
	Max. ambient temperature w/ activated charcoal: 140° F



Pressure Regulator/water separator

92288	SATA 420 Line Pressure Regulator High air volume of 141 cfm, up to 225 psi, outlet G 1/2 female thread	
92213	SATA filter 414 5 micron oil / water separator with automatic condensation discharge, with ball valve air connection module but without regulator. 1/2 inch internal inlet thread and two 1/4 inch external outlet thread. (2 x G 1/4 male thread)	
92254	SATA filter 414 in-line 5 micron oil / water separator with automatic condensation discharge, without ball valve air connection module and regulator for in-line installation. 1/2 inch internal inlet/ outlet thread. (G 1/2 female thread)	
92221	SATA filter 424 5 micron oil / water separator unit with automatic condensation discharge, pressure regulator and ball valve air connection module. 1/2 inch internal inlet thread and two 1/4 inch external outlet thread.	
92262	SATA filter 424 L 5 micron oil/water separator unit with automatic condensation discharge and pressure regulator. Does not include ball valve air connection module. 1/2 inch internal inlet/outlet thread.	

Fine filter

92239	SATA filter 434 0.01 micro-fine filter unit with ball valve air connection module. Provides 99.998% clean air. Compressed air must be pre-filtered when using this unit. 1/2 inch internal inlet thread and two 1/4 inch external outlet thread.	
92270	SATA filter 434L 0.01 micro-fine filter unit without ball valve air connection module. Provides 99.998% clean air. Compressed air must be pre-filtered when using this unit. 1/2 inch internal inlet/outlet thread.	

Activated charcoal filter to retrofit SATA filter 444

92247	SATA filter 464 Single-stage activated charcoal filter without pressure regulator, with outlet module (2 x G 1/4 male thread)	
141473	SATA filter 464 Add-on unit with fittings without module	
92247L	SATA filter 464 Line filter unit without fitting and module	

Technical modifications and printing errors reserved

Spare Parts SATA® filter 414™/ 424™/ 434™/ 464™

Order No./ Desc.

2949	Diaphragm
15511	Auto. condensate valve only
22046	Pressure gauge
22087	"O" ring
22129	Teflon ball valve
22137	Cyclone tube
22152	"O" ring
22160	Sintered bronze filter
23804	Pressure valve, complete
24471	PVC nut with "O" rings
24489	Mounting rod with pressure valve
24521	Baffle with "O" ring
24554	Housing tube with auto. cond. valve
24562	Adapter with "O" ring
28506	"O" ring
28514	"O" ring
73890	Threaded rod
80457	Spindle, complete
81810	Fine filter
84749	"O" ring, 33 x 2
84871	Housing Tube, 2nd Stage
85142	"O" ring, 30 x 1.5
85373	Activated charcoal cartridge
94979	Repair kit, 400
95000	Union fitting, 1/2"
95851	Countersunk screw
96578	Valve housing
96750	Packing Kit
96883	Regulator adjusting knob
158808	Manifold, 2 drop

SATA filter 424

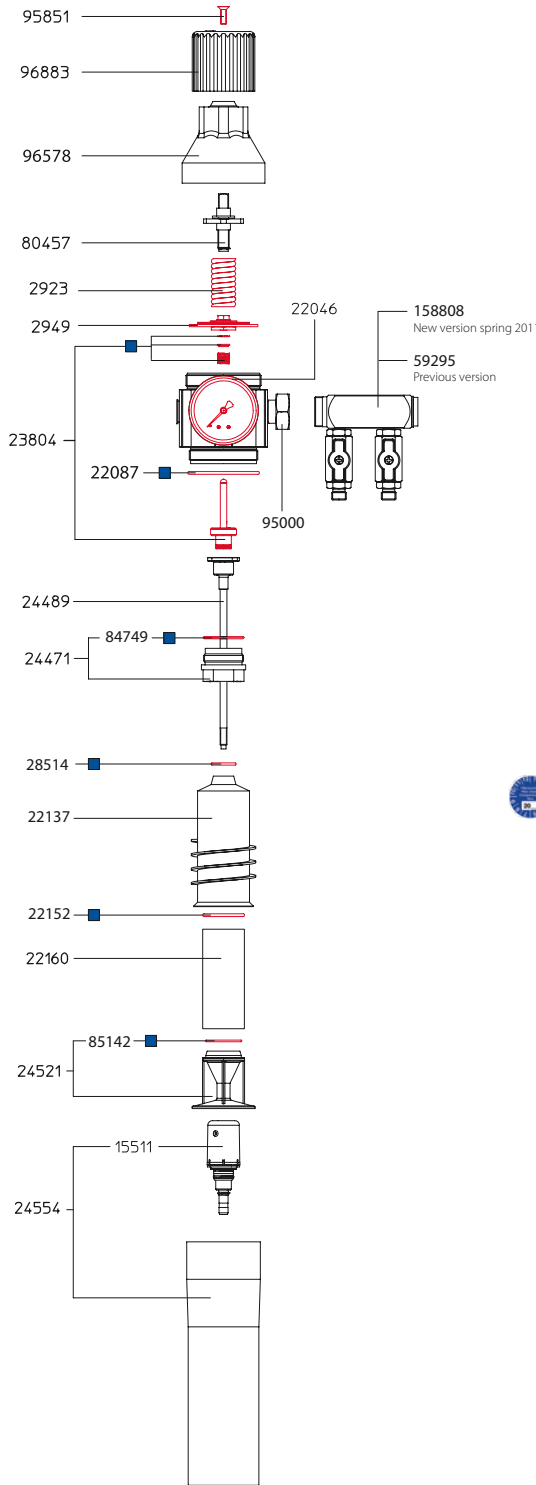

SATA filter 434



Stage 2

SATA filter 464



Stage 3

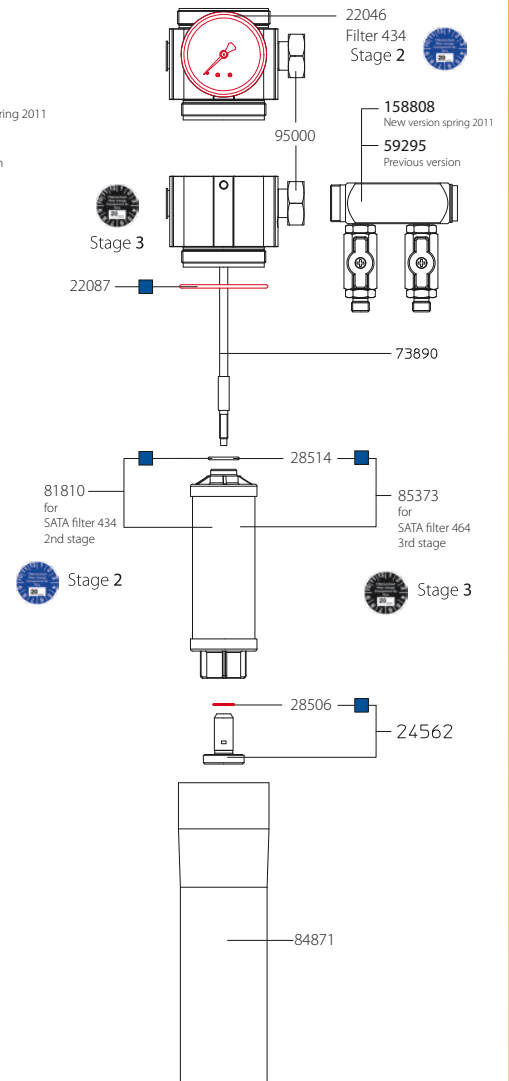

Order No./ Desc.

- 94979 Repair kit
- 96750 Packing set

Technical modifications and printing errors reserved

SATA® filter 444™/ 474™/ 484™

The SATA 400 modular filter series is designed to meet the highest standards of quality and performance. The modular system allows the user to adapt to varying shop conditions and requirements. Easy to service and maintain with no desiccant related problems. Dual gauges monitor pressure differential, thus a pressure variation of 10 to 15 psi or more indicate filter maintenance is required.

- High air volume capacity of 129.6 cfm at 90 psi
- Fully automatic condensation discharge
- Anti-corrosion proof
- Temperature resistant up to 248° F (charcoal units up to 140° F)
- No desiccant maintenance
- Rugged all metal housing for long service life







SATA combination filter systems are especially suitable for use with supplied air respirators providing 100% (technically 99.998%) clean breathing air.

SATA filter 400

Technical Data

Air inlet: G1/2 i	Air flow at 6.0 bar: 3,600 NI/min / 129 cfm @ 90 psi
Air outlet: G 1/4 a	Max. ambient temperature: 248° C
Max. inlet operating pressure: 15.0 bar / 217 psi	Max. ambient temperature w/ activated charcoal: 140° F
Max. outlet operating pressure: 10.0 bar / 145 psi	Air flow at 6.0 bar: 3,600 NI/min / 129 cfm @ 90 psi

Combination Filter

92296	SATA filter 444 Double-stage sinter filter/fine filter with pressure regulator and outlet module (2 x G 1/4 male thread)	
92833	SATA filter 444 with floor carrying support	
92296L	SATA filter 442 in-line Double-stage sinter filter/fine filter with pressure regulator for air installation (G 1/2 female thread) no module	
92312	SATA filter 474 Double-stage fine filter/activated charcoal without pressure regulator, with outlet module (2 x G 1/4 male thread)	
92320L	SATA 482 filter In-line version of the SATA 484 three stage filter unit. No regulator or manifold. 1/2 inch internal inlet and outlet threads	
92320	SATA 484 filter Triple-stage sinter filter/fine filter/activated charcoal filter with pressure regulator and outlet module (2 x G 1/4 male thread)	

Technical modifications and printing errors reserved

Spare Parts SATA® filter 444™/ 474™/ 484™

Order No./Desc.	
2923	Spring
2949	Diaphragm
15511	Auto condensate valve only
22046	Pressure gauge
22087	"O" ring
22129	Teflon ball valve
22137	Cyclone tube
22152	"O" ring
22160	Sintered bronze filter
23804	Pressure valve, complete
24471	PVC nut with "O" rings
24489	Mounting rod with pres. valve
24521	Baffle with "O" ring
24554	Housing tube with auto. cond. valve
24562	Adapter with "O" ring
28506	"O" ring
59295	Outlet manifold, std
73890	Threaded rod
78360	Seal
80457	Spindle, complete
81810	Fine filter
84749	"O" ring, 33 x 2
84871	Housing Tube, 2nd Stage
85142	"O" ring, 30 x 1.5
85373	Activated charcoal cartridge
92569	Wall mounting kit (not illus.)
94979	Repair kit, 400
95000	Union fitting, 1/2"
95851	Countersunk screw
96578	Valve housing
96883	Regulator adjusting knob

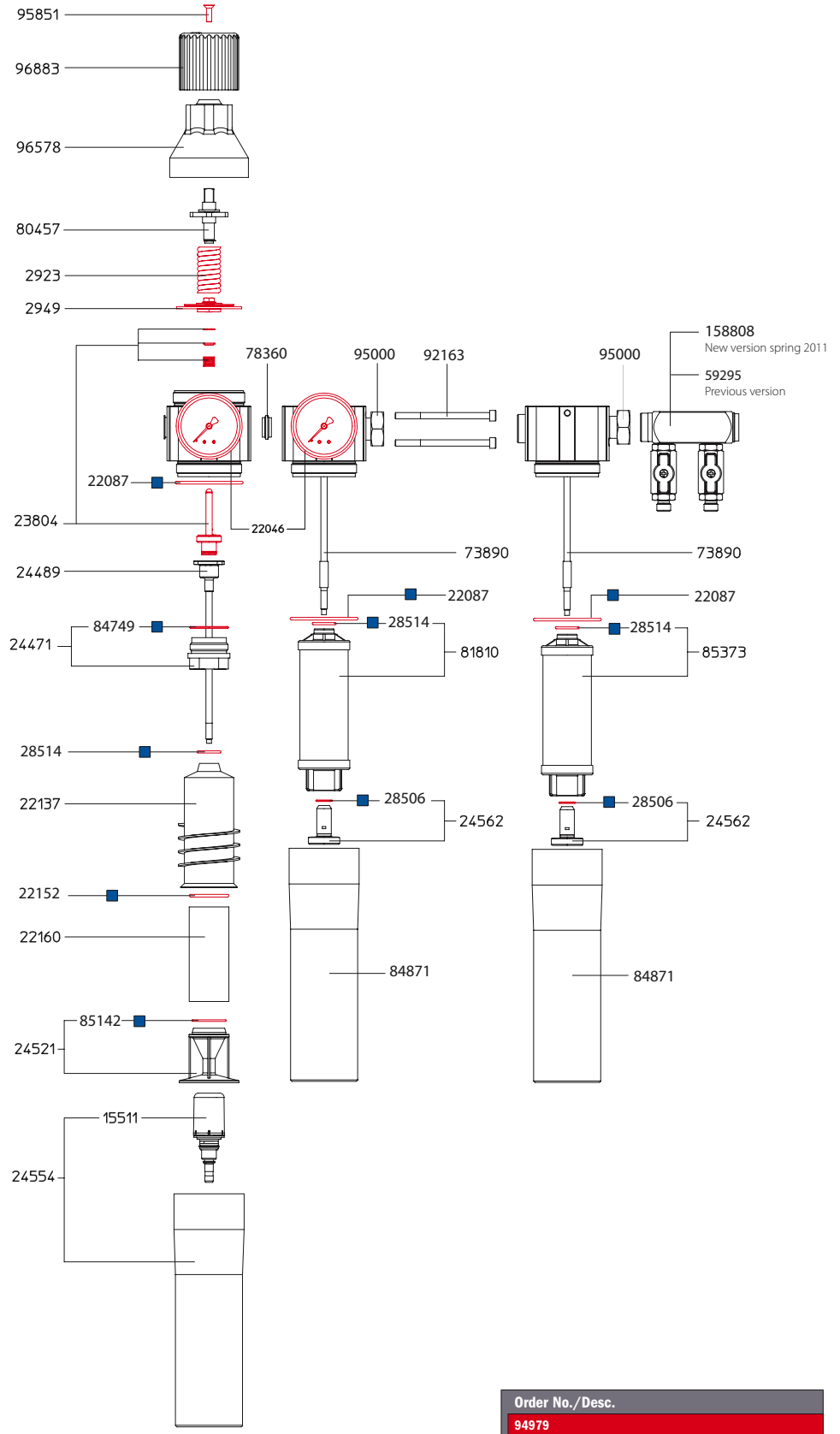

Order No./Desc.
94979
Repair kit
96750
Packing set

Technical modifications and printing errors reserved

SATA® filter 222™/242™/ 244™/ 284™







Along with the 400, the 200 filter series is the most versatile modular filter system currently on the market but at an unbeatable price. The 200 is rated at 72 cfm @ 90 psi, more than adequate for many small shops. It can be connected to compressed air pipes from either the right or left side. When atomized air leaves the spray gun, it must be clean, dry and free of condensation, silicone, oil or any other contamination. Otherwise, the finished result can have a dull finish, fish eyes, water or dust. Clean, pure air is also a must for breathing air.



SATA filter 200 series

Technical Data	Air inlet: G1/2 i
	Air outlet: G 1/4 i
	Max. operating pressure: 10 bar / 145 psi
	Max. ambient temperature: 248 °F
	Air flow rate: 72 cfm @ 90 psi

SATA 200 series

141226	SATA 264 Activated Charcoal Filter Activated charcoal unit removes oil vapor and organic odors. Pre-filtering compressed air is required.	
43687	SATA filter 222, 5 micron Single-stage sinter filter with pressure gauge, automatic condensate discharger, w/o regulator (G 1/2 female thread) 5 micron Use as an unregulated line filter	
43752	SATA filter 242, 0.01 micron Double-stage sinter filter/fine filter with pressure regulator for air installation (G 1/2 female thread) Use as an unregulated line filter for very fine particle separation	
44404 44404-4	SATA filter 244 0.01 micron with 2 drop manifold with 4 drop manifold Double-stage sinter filter/fine filter with pressure regulator and outlet module (2 x G1/4 male thread) Use to connect regulated air to aier tools and breathing air	
189290	SATA 284 Triple Stage In-Line Filter An economical three-stage filter unit. Stages include a 5 micron filter with automatic condensation discharger, a 0.01 micron fine filter and an activated charcoal filter for breathing air or spraying water borne. Used with the SATA supplied air respirator industrial belt valve or ensuring removal of oil residue when spraying water borne paint.	
141218 141218-4	SATA 284 triple stage filter With 2 drop manifold With 4 drop manifold Triple-stage sinter filter/fine filter/activated charcoal with pressure regulator and outlet module (2 x G1/4 male thread) Used in conjunction with the SATA supplied air respirator industrial belt valve or ensuring removal of oil residue for spraying water borne paint	

Technical modifications and printing errors reserved

Spare Parts SATA® filter 222™/242™/ 244™

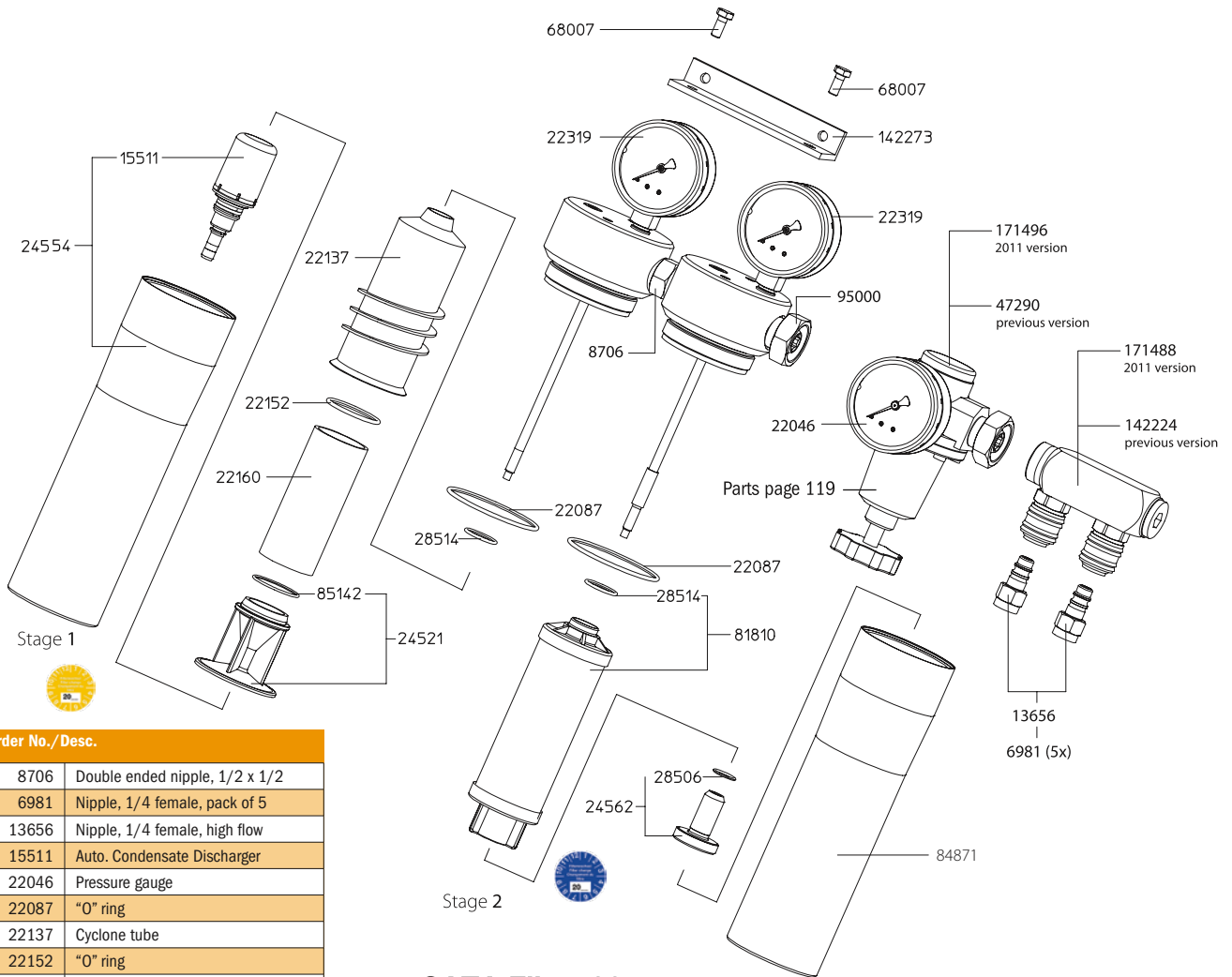

Order No./Desc.	
8706	Double ended nipple, 1/2 x 1/2
6981	Nipple, 1/4 female, pack of 5
13656	Nipple, 1/4 female, high flow
15511	Auto. Condensate Discharger
22046	Pressure gauge
22087	"O" ring
22137	Cyclone tube
22152	"O" ring
22160	Sintered bronze filter
22319	Pressure gauge, 134, 334
24521	Baffle with "O" ring
24554	Housing tube with auto. cond. dis.
24562	Adapter with "O" ring, 300
28506	"O" ring,
28514	"O" ring, 300 line
37622	Fixing angle, single filter
47290	Pressure regulator with gauge previous to 2011
68007	Hex screw, M6x14
81810	Fine filter, 134, 334
84806	Aluminum plug washer
84871	Housing tube, 2nd and 3rd stage
85142	"O" ring 30 x 1.5 300
85357	Housing spanner wrench (not illus.)
85373	Activated charcoal filter w/O-ring
95000	Union fitting
142224	Outlet manifold w/QC couplings and nipples, previous version
142273	Fixing angle, double filter
171488	Outlet manifold w/QC couplings and nipples, 2001 ver.
171496	Pressure reg. with gauge, 2011 ver



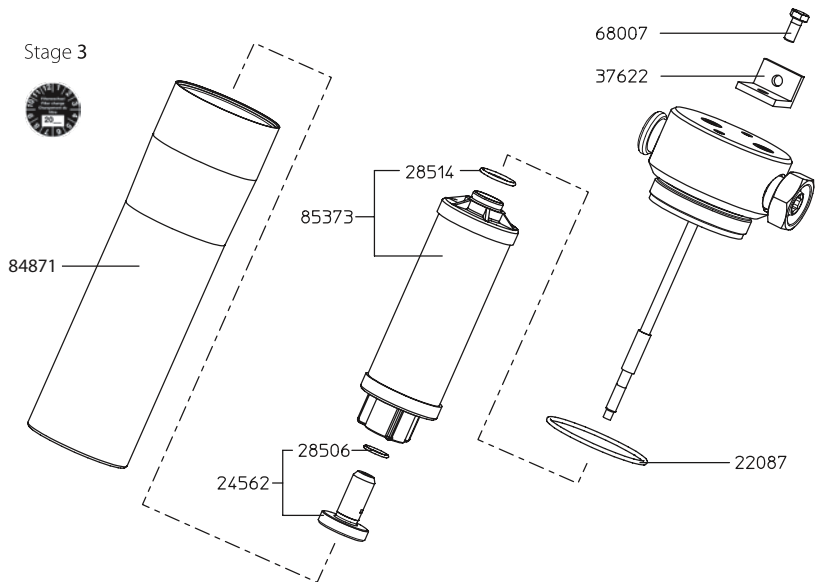





SATA Filter 264

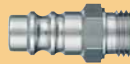









Technical modifications and printing errors reserved



Accessories for SATA® filter series

Filter cartridges		
22160	Sinter filter for SATA filter series 100, 200, 300, 400	
81810	Fine filter cartridge for SATA filter series 100, 200, 300, 400	
85365	Ultra fine filter	
85373	Activated charcoal cartridge for SATA filter series 200, 300, 400	
138933	Service kit for filter cartridges: plastic case + 81810 + 85373	

Filter accessories		
13656	SATA HVLP female nipple G 1/4 female thread (use 6981 for 5-pk)	
53942	SATA HVLP male nipple G 1/4 male thread	
13599	SATA HVLP female coupler G 1/4 female thread	
13623	SATA HVLP male coupler G 1/4 male thread	
158824	Manifold, cpl., for extension with 2 connections	
158824-4	Manifold, cpl 4 connections	
96743	Air connection manifold for 494 middle module only	
158808	Filter Outlet Manifold, 2011 Version	
158808-4	Standard 2 drop outlet manifold with/4 drop manifold	
158824	Manifold for 494 filter middle module only	
171488	Manifold, 2 drop, 200 series	
171488-4	Manifold, 4 drop, 200 series w/coupler and nipple	
171496	Pressure regulator, 200 series	

Filter accessories		
10934	Teflon ball tap G 1/2 inch male thread for air in- and outlet, for 4000 series filters	
9878	Not a cheap throw-away. Dust, oil and condensation are filtered directly at the spray gun. 10 micron performance through sintered bronze. Condensate discharge valve. Weighs 4.4 oz.	
86892	SATA's Auto discharger is a fully automatic drain valve to eliminate condensation from your down pipes and airline drops. It is 1/2" NPT to easily connect to your drops. This requires no electricity, so can be place inside explosion proof areas.	

Point of use Regulator		
47290	SATA Pressure Reg. for exact pressure setting. 1/2" connection Max. inlet pressure 140 ps	
142224	SATA Air Connector Manifold with two couplings and two nipples, 1/2" connection	
142224-4	4 drop manifold	
47290A	Point of use regulator w/two drop manifold, mounting bracket and LocTITE	
47290A-4	4 drop manifold	
47290B	Regulator mounting bracket only	
675652	Dan-Am point of use regulator with two drop manifold, mounting bracket Max inlet pressure: 216 psi Max. cfm: 140	

Air quality control		
156299	SATA air tester, compressed air quick tester for contaminates	
7096	Compressed air testing device. Simply connect and allow air flow for 15 minutes or longer. Test paper traps dirt, oil and in-line contamination. Complete with test paper, tweezers, magnifying glass and exam light all in a compact carrying case.	
7666-10	Test paper, pack of 10	
7666-50	Test paper, pack of 50	
7666-100	Test paper, pack of 100	

Spare Parts

Pressure Regulator #47290

Order No./Desc.

2980	Diaphragm
13490	End screw cover
13912	Compression spring
14019	Valve Pin
14035	O Ring
14043	Valve seat
14068	Head piece
14076	O Ring (End Cap)
14522	O Ring 25 x 15
14530	Compression spring
16816	Bell housing
17251	Cylinder screw
17541	Counter nut M10 x 1
17590	Spindle
18077	Adjusting knob
18358	Nut, Adjusting knob
90951*	Diaphragm Repair Kit

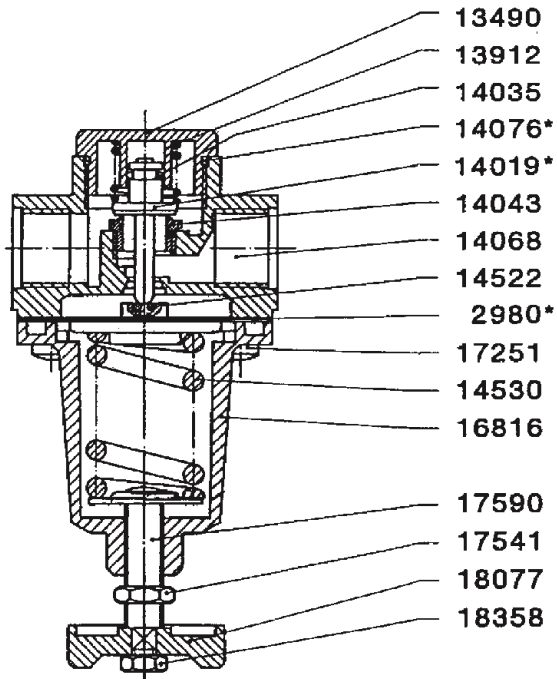

Part No./Description

*90951
Diaphragm Repair Kit

Filter Head Connection

Due to a design change on the SATA filter 400 series, the number of parts required for the connection between the 2nd and 3rd filter stage as well as between the 3rd filter stage and the outlet module has been reduced from three to only two parts.

The design of the filter head has been changed as well in order to slightly reduce the total weight of the filter unit (see illustration on the right under NEW).

SATA filter 400 series,
OLD filter head, Previous
3 piece connection



SATA filter 400 series,
NEW filter head, Spring 2011
2 piece connection



NEW outlet module for SATA filter 200 & 400 series

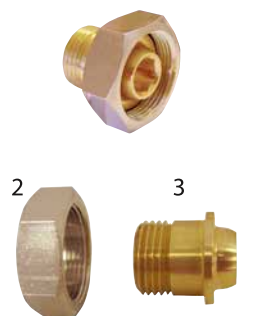

NEW Spring 2011

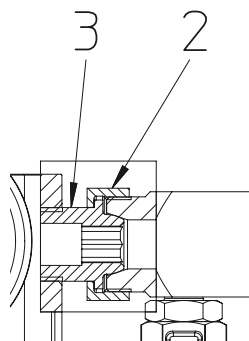

2 piece connection
Part # 95000

- 2. Union nut
- 3 Insert

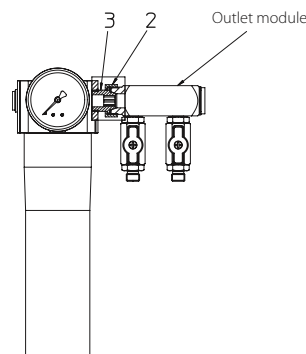

For the assembly of the new and old outlet module for the SATA filter 400 series, use Part No. 9500, new design modules already feature a male thread. The insert part is now installed on the opposite side, i.e. inside the activated charcoal filter unit, while the swivel-screw fitting (position 1 shown below), is no longer necessary.

Similar changes have been made to the SATA filter 200 series as well. Please refer to the respective parts breakdown for the correct module.

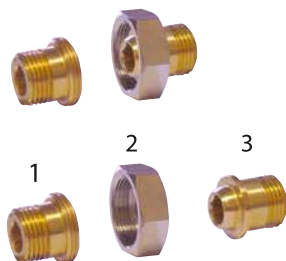

OLD

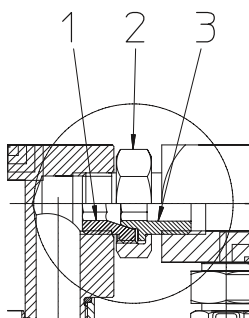

3 piece connection
Part # 95000

- 1. Swivel-screw fitting
- 2. Union nut
- 3 Insert

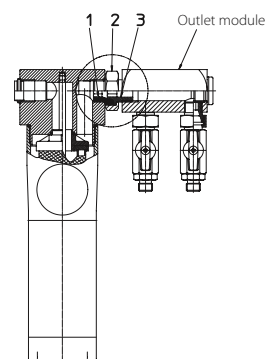

SATA 400 Series Filter Cutaway

Precise regulation of operating pressure

Air flow
130 cfm @ 90 psi

Differential pressure reading of fine filter saturation

Reusable filter elements require little service

Cyclone separator

Sintered bronze filter
Part No. 22160

Stage 1

Stage 2

Stage 3

Low maintenance with high operating safety due to automatic condensation discharge

Corrosion-proof metal housing

Easily replaced fine filter cartridge
Part No. 81810

Activated charcoal filter cartridge
Part No. 85373

Technical modifications and printing errors reserved

Accessories



SATA® clean RCS™ / SATA® multi clean™ 2

- Safe and rapid color change with disposable cup use, even with critical changes (e.g. black / white)
- Mounts in the spray booth or in the preparation room
- Suitable for waterborne and solvent-based paint systems
- High cleaning power and residue-free removal of all paint remainders in the paint channel, even in places hard to access
- Collecting container for used cleaning liquid avoids additional soiling of the spray booth – lasting profitability and savings potentials due to increased booth filter life time
- No readjustment of the gun inlet pressure and no disconnecting required – automatic pressure adaptation when switching between “Spraying” and “Cleaning”
- Shelf space for prepared disposable cups during paint jobs
- Increases paint job frequency and capacity utilization of the spray booth

Only 2 cleaning steps:

1. Flushing and cleaning the paint channel and air cap
(approx. 21 sec.)



2. Dry-blowing; used cleaning liquid is collected
(approx. 4 sec.)

SATA clean RCS

Technical Data	Inlet pressure: max. approx. 87 - 116 psi / 6.0 - 8.0 bar
	Dimensions: 12 x 28 x 9 inches / 310 x 705 x 225 mm
	Net weight: 22 lbs / 10 kg

SATA clean RCS

146944	SATA cleanRCS - the turbo cleaner -
--------	-------------------------------------



SATA clean RCS compact

Technical Data	Inlet pressure: max. approx. 60 psi / 4.0 bar
	Dimensions: 12 x 17.5 x 9 inches / 310 x 465 x 225 mm
	Net weight: 15.5 lbs / 7 kg

SATA clean RCS

146944	SATA clean RCS compact - the turbo cleaner -
--------	--



Recommended connection set and Accessories

10934	Teflon ball tap G 1/2 inch male thread for air in- and outlet	
146514	Air hose 13 mm, 500 mm long, with connection for SATA cleanRCS	
13581	SATA quick coupling 101.38 g 3/8 female thread	
147082	Grounding cable, 10 ft, 4 mm, assembled	
9886	SATA gravity gun holder for gravity cup spray guns	
146985	Repair kit SATA clean RCS	
146993	Splash guards and fixing rivets, pack of 5 each	
147017	Replacement brush, pack of 2	
147025	Replacement tubes, pack of 2	
189472	Conversion kit external cleaning agent - suction and recirculation for SATA clean	

Errors, technical modifications and printing errors reserved.

Cleaning and Maintenance of Spray Guns



Intermediate Cleaning

Intermediate cleaning with SATA cleanRCS

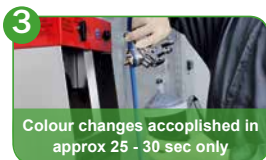
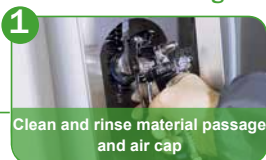

Automatic gun cleaning

Cleaning with gun washing machine SATA multi clean 2

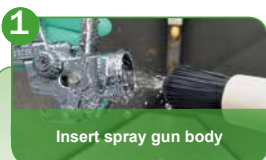

Please ensure that the spray gun is always placed in the correct position inside the washing chamber of self-contained washing machines. **Make sure that no cleaning agent penetrated the air passages of the spray gun.**

Important Note

It is **essential** to observe the **pH value** of your cleaning agent!

The pH value should be ranging between 6 - 8!

Disassembly and manual cleaning

Disassembly of nozzle set

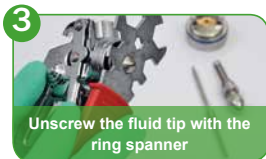
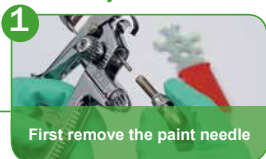

Cleaning and drying of the spray gun...

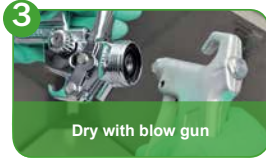
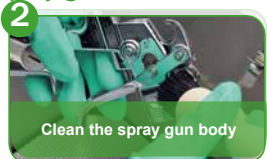
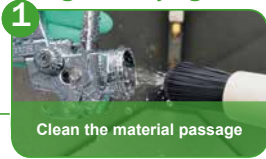

... and the nozzle set



Assembly and Maintenance

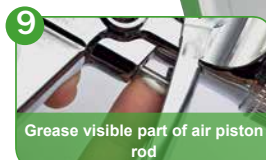
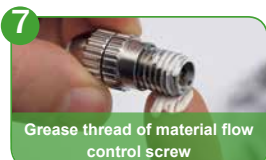
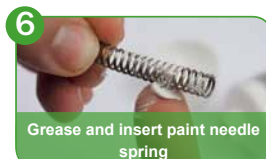
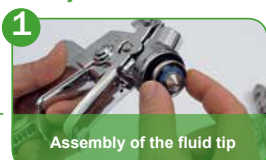

Cleaning Accessories



Order No. 158840
5 cleaning brushes, large for cleaning the outside of the gun body



Order No. 6007
10 cleaning brushes, medium size for fluid tip and material passages of gun



Order No. 9209
10 double-sided cleaning brushes for cleaning air caps and fluid tips



Order No. 62174
12 nozzle cleaning needles for cleaning front apertures of air cap and fluid tip



Order No. 48173
High performance grease, 100 ml, silicone and acid free for all moving parts of the gun



Order No. 64030
Cleaning kit consisting of 2 cleaning brushes and 12 cleaning needles



Order No. 162628
SATA care set - bag containing tools for spray gun cleaning and maintenance. Offers extra pockets for additional maintenance tools.

Scope of supply:

- 1x Cleaning brush, large 1
- 5x Cleaning brushes, medium 2
- 5x Cleaning brushes, double-sided 3
- 12x Nozzle cleaning needles 4
- 1x high performance grease, 100 ml 5

Please make sure that all brushes being used **have no protruding metal wires** as these may damage the spray gun. Please exclusively use recommended tools for cleaning only.

We recommend leaving the spray gun connected to the air circuit with **reduced pressure** even for manual cleaning. Make sure that cleaning agent never enters the air passages of the spray gun.

Please watch our video at www.sata.com/TV concerning **Cleaning and Maintenance of Spray Guns**.

Or simply request our brochure #158162 for thorough guidelines.

To order Spray Gun Cleaning poster use part no. **158162P**



www.satausa.com

Errors, technical modifications and printing errors reserved.

SATA® dry jet™

SATA dry jet

Technical Data

Air consumption: 10 cfm
Inlet pressure: 36 psi
Max inlet pressure: 174 psi



Available version

82222	<p>SATA dry jet</p> <p>This practical, lightweight blow gun makes quick work of drying waterborne material. A special nozzle design multiplies air volume from ambient air using the Venturi injection principle. An air intake filter prevents contamination of the paint. The SATA dry jet blow gun is now available with or without the handle and shut-off valve. Air consumption is only 8.2 cfm at 29 psi.</p> <p>SATA dry jet blow gun w/handle and valve.</p>	
144105	<p>The SATA dry-jet "S" is specifically designed for mounting on one of our blow gun stands.</p> <p>The dry-jet "S" makes drying waterborne very quick and convenient.</p>	

SATA dry jet stand (adjustable height: 30 - 190 cm)

82198	Dry-Jet stand only, complete without blow guns	
82230	SATA dry jet stand with height adjustable fixing and 2 blow guns (82222)	
144113	SATA dry jet stand with height adjustable fixing and 2 "S" blow guns (144105)	
161489	Jumbo stand w/4 SATAdry-jet blow guns	
84145	Height extension, approx. 1.2 m (47.2") for SATA dry jet stand	
86140	Width extension for SATA dry jet stand with one blow gun (82222)	
145318	Width extension with one dry-jet "S" blowgun (144105)	

Spare Parts SATA® dry jet™

Order No./Desc.
81830 Hose only, Sata dry-jet adjustment mount
81869 Filter holder
82198 Stand w/o blow guns
82248 Filter, pack of 3
83832 Cross bar connection
83840 Stand complete (can be disassembled)
84145 Verticle extension approx 1.2 m stainless steel
86140 Horizontal extension w/ third blow gun

Order No. 82222

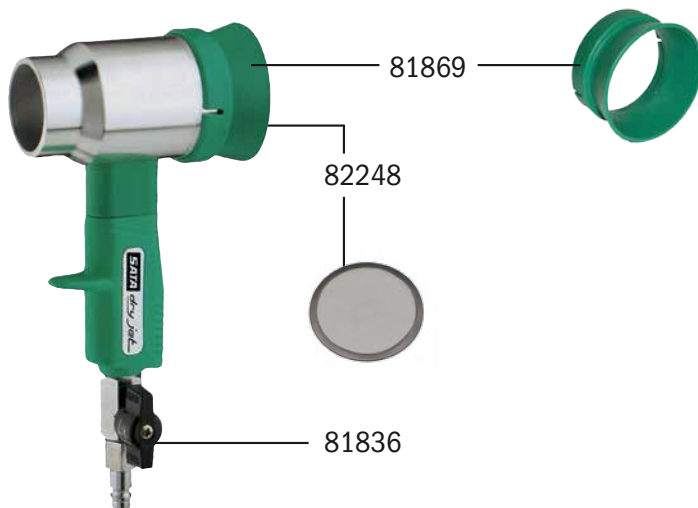

Art. No. 82230
Illustration without SATA
dry jet blow guns

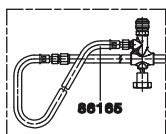
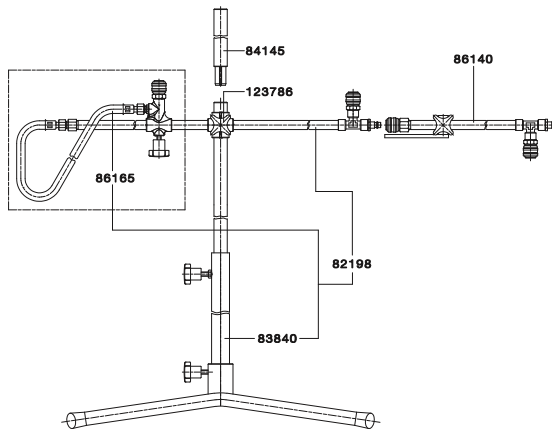

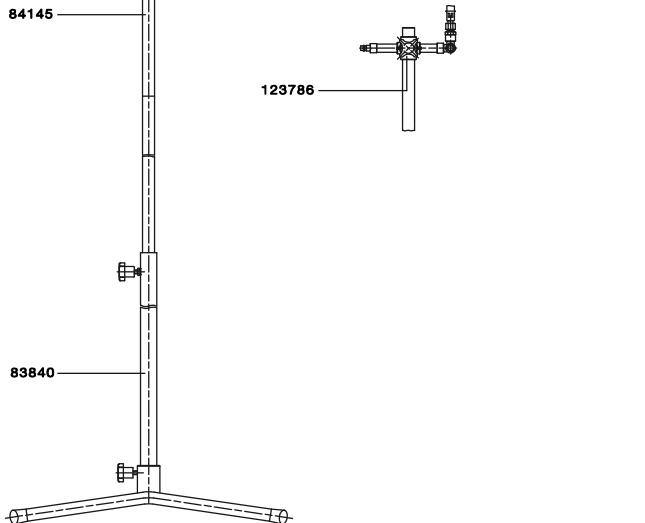

Art. No. 161489
Illustration without SATA
dry jet blow guns

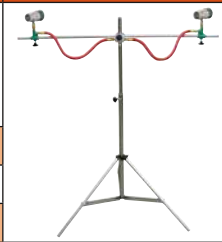

Errors, technical modifications and printing errors reserved.

Dan-Am blow gun stands

Dan-Am jet dry stands		
This Dan-Am mobile stand can hold up to three SATA dry-jet guns with its' large 48" horizontal mounting bar, no extension needed. Adjustable gun height from 40" to 88", with 360° swivel or tilt. Supplied with high flow connections and hoses for maximum performance of the blow gun. It is easily set up and compact for storage, made of corrosion resistant zinc plated tubular steel with an aluminum tripod. The stand will be offered as a package with two guns		
720700	Dan-Am jet dry stand only	
720610	Dan-Am jet dry stand with 2 SATA dry-jet "S" (144105) blow guns	
720600	Dan-Am jet dry stand with 2 SATA dry-jet (82222) blow guns	
Econo-jet Blow Gun Stand		
This economical mobile stand holds up to two SATA blow guns, adjustable gun height, with 360° swivel or tilt. Supplied with high flow connections and tubing for maximum performance of the blow gun. It is easily set up and compact for storage. It is fully compatible with SATA's dry-jet blow gun and the SATA dry-jet "S". The stand will be offered as a package with with two guns. This is a must have tool for drying waterborne paint, as waterborne dries substantially faster with air flow, saving time for more added production.		
720580	Econo-Jet stand only	
720610	Econo-Jet stand w/ 2 SATAdry-jet "S" blow guns (144105)	
720600	Econo-Jet stand w/ 2 SATAdry-jet "S" blow guns (82222)	

Parts Dan-Am blow gun stands

Dan-Am Jet-Dry Stand

Order No./Desc.	
80200	Gun Mount
671029	1/4" Male Hex Nipple
671032	1/4" Street Tee
720701	3 pc. Pipe Set
720703	Tripod Only
720704	3/8" x 22" Hose
720705	Knob
720707	Cross Piece
720714	Hi Flow Nipple
720716	Hi Flow Coupler

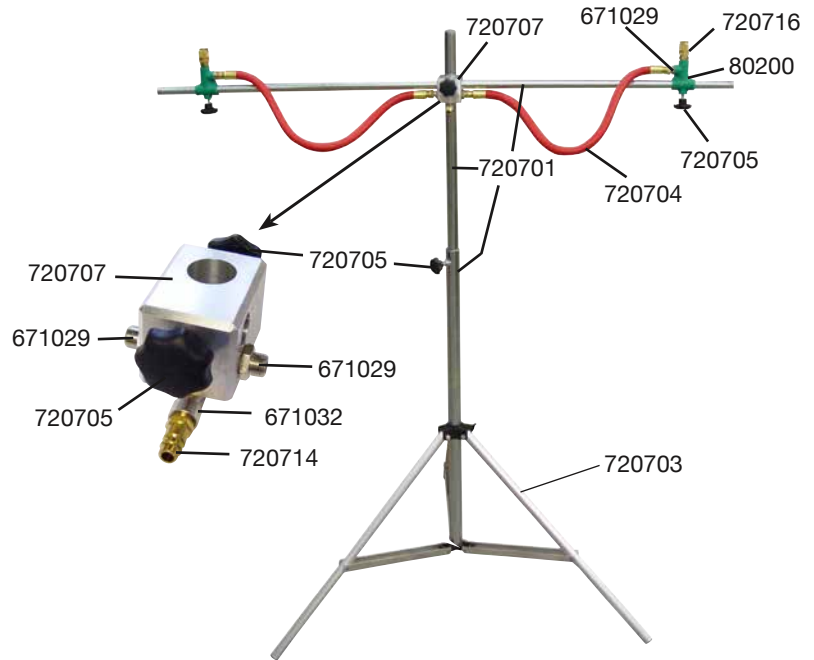





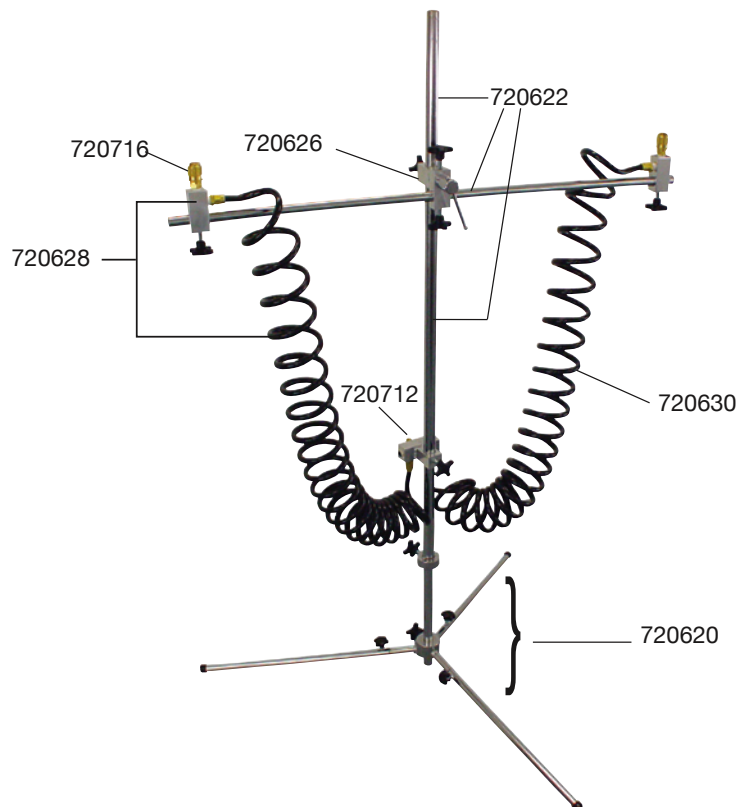





Dan-Am Econo-Jet Stand

Order No./Desc.	
720620	Base Assembly
720622	3 pc. Pipe Set
720624	Knob, set of 4
720626	Swivel Cross Assembly
720628	Air Delivery Component Set
720630	Coil Air Hose
720712	Hi Flow Nipple
720716	Hi Flow Coupler



Grit Blasting Equipment / Blow Guns

Grit blasting equipment		
17335	SATA grit blasting gun super version spraying pipe w/ carbide insert	
39172	SATA sandblasting set: sand blast gun with carbide pipe, mask, gloves, blast material special order item only	
17699	SATA sandblasting hood	

Blow guns		
<p>SATA blow guns reduce costs by saving compressed air. Three types of nozzles are available in standard, noiseless and multi nozzle. The high efficiency multi nozzle design triples the air volume by means of a <i>following-up effect</i>. The noiseless type lowers the noise level to 79 db at 60 psi. Straight and curved nozzle extensions are available for special requirements. Air consumption of about 5 cfm at 45 psi. SATA Multi and Noiseless nozzle versions prevent pressure build-up if tip is blocked or "dead ended" Complies with OSHA requirements 1910.242b and 1910.95 when used on an air line of 150 psi or less. The standard version does not have safety by-pass and must use regulated pressure not exceeding 30 psi.</p>		
15156	SATA blow gun with standard nozzle (blow gun)	
26070	Standard nozzle for SATA blow gun 15156 (blow gun)	
15180	SATA blow gun with low noise metal nozzle and quick coupling nipple (blow gun)	
77586	Special low noise nozzle for SATA blow gun 15180 (blow gun)	
15214	SATA blow gun with multi nozzle and quick coupling nipple (blow gun)	
26047	Metal multi-nozzle M14 x 1	
133306	SATA turbo blow with quick coupling nipple (blow gun)	

Errors, technical modifications and printing errors reserved.

Spare Parts SATA Grit Blasting, Blow gun, UBE undercoating, Dosen-Boy

Order No./Desc.	
12831	Hexagon nut SPO ascending pipe
17699	SATA HMO head protection hood
21154	Blast pipe w/carbide insert
21451	Lid for 0.6 l PVC suction cup
25411	Blast pipe w/ carbide insert
38141	SATA SGE gun with carbide spray pipe
64394	Screen, pack of 5
64402	Glass visor screens, pack of 5

SATA grit blasting gun

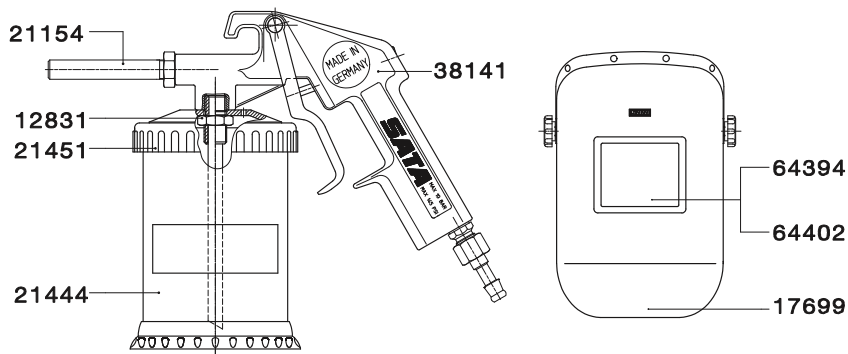

Order No./Desc.	
109	Air inlet fitting
15156	Blow gun, standard
15180	Blow gun, noiseless
15214	Blow gun, multi-nozzle
26047	Head, multi-nozzle
26070	Head, standard
55269	Gun body
77586	Head, noiseless

SATA Blow Gun

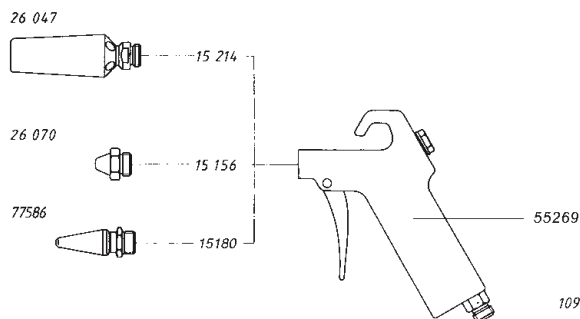

Order No./Desc.	
4788	Trigger
11098	Packing, air piston
11437	End screw
12864	Spray tube
26054	Pressure spring
53082	O ring, air piston
65979	Air piston
65987	Trigger pin
65995	Pickup tube
66001	Nozzle
66019	Circlip

SATA UBE Undercoating Gun (#12740 for one way cans-euro)

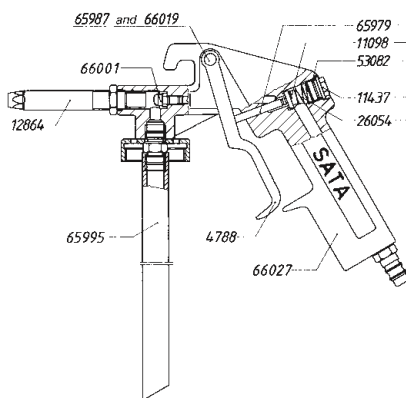



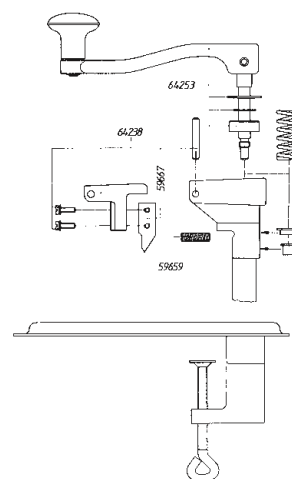

SATA Dosen-Boy (tin can opener)



Order No./Desc.	
59659	Transport gear
59667	Blade
64238	Blade assembly
64253	Handle assembly

Errors, technical modifications and printing errors reserved.

Rustproofing Equipment

Cavity preservation, Type 1		
9795	SATA HRS pressurised cup spray gun, Type 1, with 1.0 l cup with wands, flexible nylon, door and hook wand Special equipment for hollow cavity corrosion protection. Refillable 1 liter pressurized cup to 150 psi. May be used free spraying or connected to wands. Fine atomization from mixing cap and pressurized cup. The standard model uses Type 1 connection (small wand coupling). Complete with cup, quick coupling, steel door wand, flexible nylon wand and hook wand	
12658	SATA HRS pressurized cup spray gun with 1.0 l cup, material flow control, without wands, Type 1	
11072	SATA HRS pressurized cup spray gun with 1.0 l cup, material coupling, without material flow control, without wands, Type 1	
16071	Fixed door wand (steel), Type I, 1.1 m long, 8 mm, with radial nozzle 360 ° radial fan	
16113	Flexible nylon wand, 1.3 m long, Type I, 8 mm, with radial nozzle 360 ° radial fan	
11866	Venturi hook wand, 4 mm, with flexible guideway hose, Venturi spraying tube, for cavity and surface application	
11874	Flexible nylon wand 1.5 m long, 6 mm, with radial nozzle 360 ° radial fan and diagonal spray	
16139	Rigid nylon wand, Type I, 1.1 m long, 8 mm, with radial nozzle 360 ° radial fan and spraying diagonally backwards and forwards	
24372	Flat hook nozzle for HRS	
25486	Round spray nozzle for surface application and under body protection	
8359	Material coupling for clear passage for wand systems	
16048	Quick coupling nipple for wands 80-4133 G 1/4	
Cavity preservation, Type 2		
27565	SATA HRS Rust Protection, Type 2 Economy version with 1 liter pressurized cup to 150 psi., with one nylon wand (#77941) and one hooked nylon wand (#54460)	
77941	Flexible Nylon wand, 1500mm, Type 2, w #16170 coupling	
16154	Rigid nylon wand, 1100, Type 2, 1.100 mm Ø 8 mm, with radial nozzle 360 ° radial fan and diagonal	
54460	Hook wand, 750mm, Type 2	
16170	Coupling, Type 2	
16055	Hook wand nipple, Type 2	
11213	Round spray nozzle, Type 2	
Under body protection		
12740	SATA UBE suction gun for underbody protection from disposable containers Type 1, European containers (9.5" pick-up tube)	
H823W	Dan-Am undercoating gun for efficient means of rust prevention. U.S. throw away containers	

Spare Parts SATA® HRS™

Order No./Desc.	
3426	Safety washer 4 mm DIN 6799 stainless steel for trigger
8300	Suction pipe, drilled"
8318	Sealing ring
8359	Material coupling for clean passage for want systems
11437	End screw
11445	Compression spring
11460	Air piston
11494	Cam rod, complete with O-ring
11502	Paint needle 1.5, complete with needle sleeve
11510	Mixing cap, completely machined
11544	Compression spring for paint needle
12591	Bracket bolt for SATA paint spray guns except SATAmijinjet
15438	Paint needle packing
16071	Fixed door wand (steel) 1.300 mm Ø 8 mm, with radial nozzle 360 ° radial fan, Type 1
16113	Flexible nylon wand 1.300 mm Ø 8 mm, with radial nozzle 360 ° radial fan, Type 1
16139	Rigid nylon wand 1.100 mm Ø 8 mm, w/ radial nozzle 360 ° radial fan + spraying diagonally backwards + forwards, Type 1
24372	Flat hook nozzle for HRS
25486	Round spray nozzle for surface application and underbody protection
41806	1.0 l aluminum pressure pot max pressure 10 bar / 150 psi complete with threaded ring
53082	O-ring 12 x 1.5 mm made of Perbunan
68890	Valve, cpl."
133983	Air connection piece G 1/4a

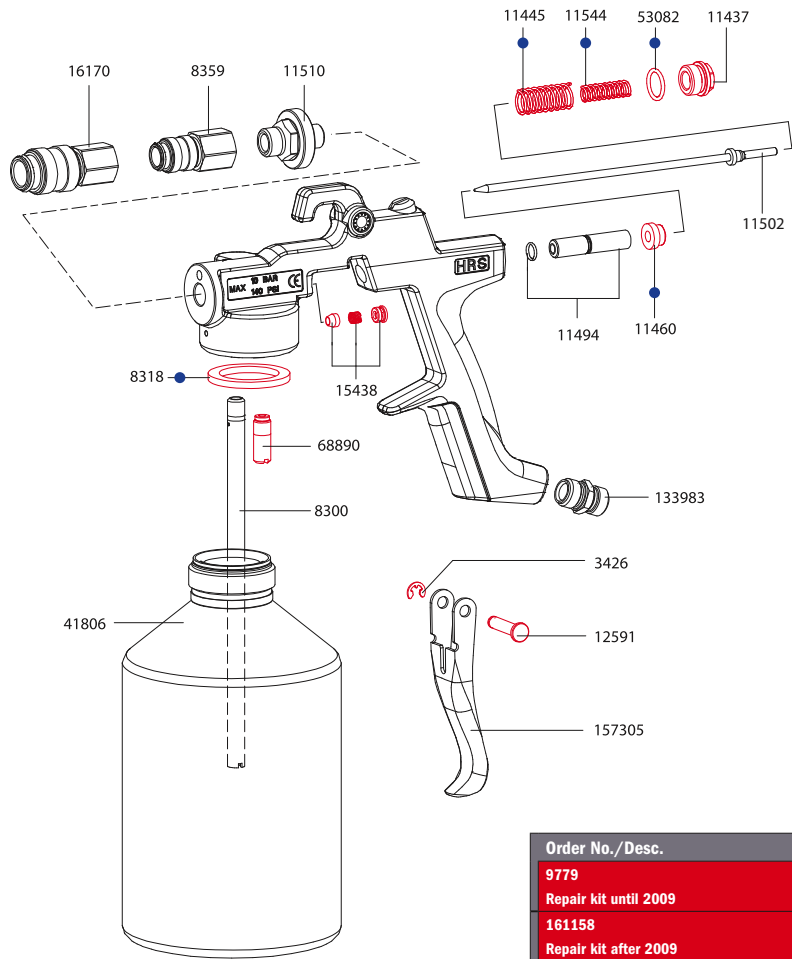

Order No./Desc.
9779
Repair kit until 2009
161158
Repair kit after 2009
50617
Air piston service set

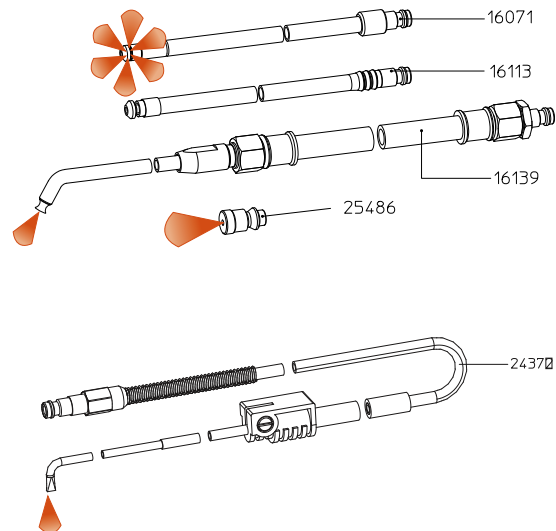

Errors, technical modifications and printing errors reserved.

Rustproofing Equipment

Barrel pump unit for cavity preservation

14555 SATA HKU pump unit 1:3 cpl., consisting of pump 3:1, with pair of hoses 10 m, jet 1000 KK spray gun, 3 wand set, connection

HKU Technical Details

Pump volume with nozzles:	app. 0.036 cfm
Air consumption spray gun:	7.1 cfm
Air consumption pump at 72.5 psi inlet pressure:	8.2 cfm
Air connection thread:	G 1/4 outs. thread
Total weight:	24.2 lb / 11 kg
Max. air pressure:	150 psi
Min. air pressure:	37.5 psi
Max. material pressure:	450 psi

HKU Technical Details

Bursting pressure:	2250 psi
Free material flow:	approx. 22 l/m
Air Connection:	G 1/4 int.
Material outlet:	G 3/4 int.
Material outlet:	suction pipe G 3/4
Noise emission at 0.MPa (105 psi):	79 dB (A)2
Barrel connection with 2" thread is supplied with the pump.	



34389 SATA HKU barrel pump unit, 200 l, consisting of pump 3:1, hose pair 10 m long, jet 1000 KK spray gun, 3 wands with connection I

153700 SATAjet 1000 KK 1.5 paint tube G 1/4a, special connection with coupling (8359) page 22 for details



17251W Wand set, 8 x 1300mm - nylon wand, an 8 x 1100mm - door wand and a venturi 750mm - hook wand

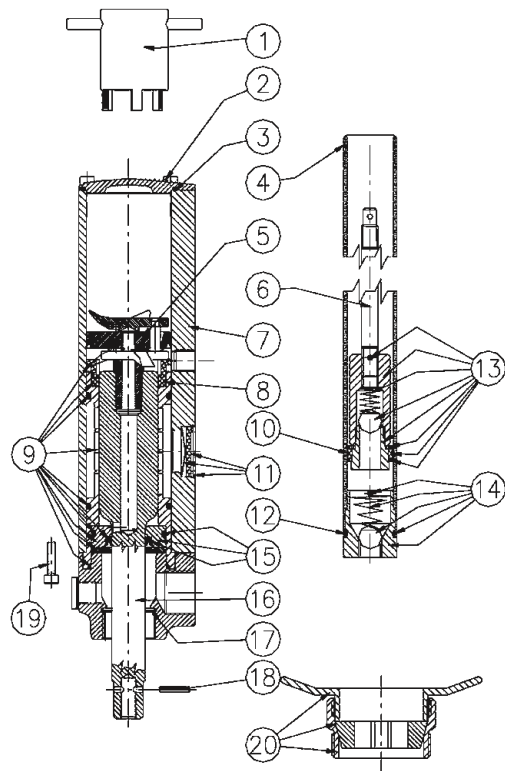

HKU pump unit

Order No./Desc.	Pos.
51961 Packing kit	8, 10, 12, 15, 17, 18
51979 Air motor repair kit	2, 3, 9, 16, 18, 19
57406 Pump tube repair kit	13, 17, 18
16063 Guiding hose	
23291 Reduction nipple	
30437 Pressure compensation containers, cpl.	
34819 SATA material-feed pump 1:3 60 l with control unit	
38679 Suction pipe for 60 ltr. Barrel	
39594 Sieve insert	
39727 Barrel-screwing	20
49494 SATA material feed pump 1:3 for 200 l, with control unit	
55517 Valve mechanism cpl.	5
57471 Bottom valve cpl.	14
57521 Piston rod	6, 18
70086 Suction tube for 200 ltr. barrel	
80622 Pump fittings	

Spare Parts SATA® HKU™ pump

See Index for Spray-Mix Material Nozzles

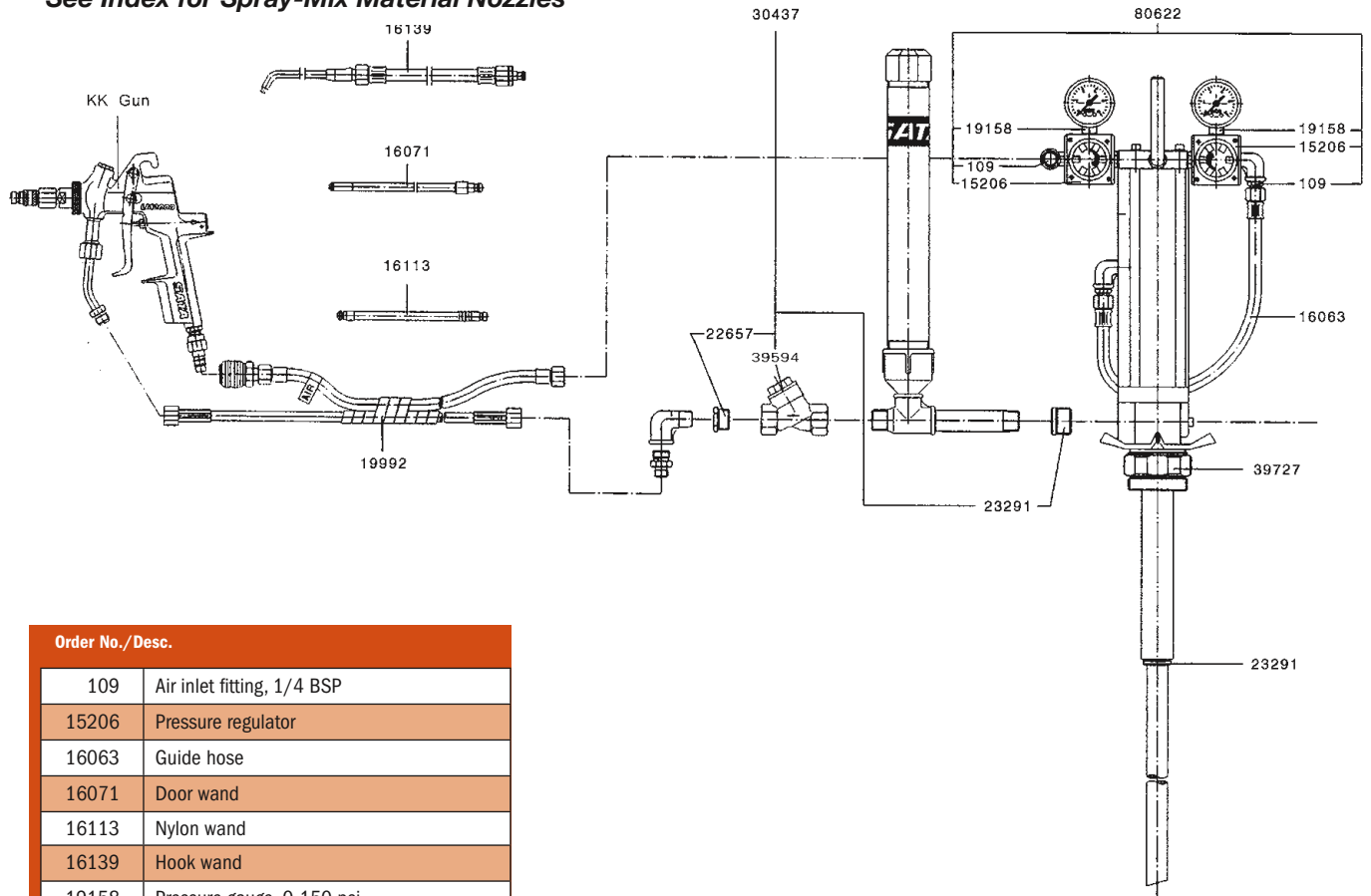

Order No./Desc.	
109	Air inlet fitting, 1/4 BSP
15206	Pressure regulator
16063	Guide hose
16071	Door wand
16113	Nylon wand
16139	Hook wand
19158	Pressure gauge, 0-150 psi
19992	10 meter combination hose, with fittings
22657	Bushing, 3/8 x 1/2
23291	Reducing nipple, 3/4 x 1/2
30437	Pressure compensation container
38679	Suction pipe, 60 liter
39594	Sieve insert
39727	Barrel screw
51961	Packing kit (#8, 10, 12, 15, 17, 18)
51979	Air motor repair kit (#2, 3, 9, 16, 18, 19)
55517	Valve mechanism, cpl. (#5) (N/A separately)
57406	Pump tube repair kit (#13, 17, 18)
57471	Bottom valve, cpl. (#14)
57521	Piston rod (#6, 18) (N/A separately)
80622	Pump regulator and fittings

Errors, technical modifications and printing errors reserved.



SATA® vario top spray™

SATA vario top spray

Technical Data	Pump ratio: 1:1
	Material Pressure: 8.0 bar / 116 psi
	Material flow volume (at 220 DH): 32 l/min
	Air inlet pressure min: 0.8 bar / 11.6 psi
	Air inlet pressure max: 8.0 bar / 116 psi
	Version and weight without add-on components Aluminum: 6 kg / 13 lb Stainless steel: 12 kg / 26 lb



Aluminum versions

81661	SATA vario top spray S, double diaphragm pump 1:1, with stand, material fine pressure regulator, without spray gun and hoses	
61507	SATA vario top spray W, double diaphragm pump 1:1, for wall mounting, with material fine pressure regulator, suction tube and 1 spray gun connection, without spray gun and hoses	
61515	SATA vario top spray F, on trolley, double diaphragm pump 1:1, with material fine pressure regulator, with suction tube	
63974	SATA vario top spray F, double diaphragm pump 1:1, on trolley w/ material fine pressure regulator, suction pipe and 2 gun connection, w/o guns	

Stainless Steel Versions - pump and material passages made of stainless steel

81406	SATA vario top spray S, for waterborne paints, w/ stand and material fine pressure regulator, suction tube and one spray gun connection	
72678	SATA vario top spray W, for waterborne paints, wall mounted version, with suction tube, w/o gun or hoses	
72694	SATA vario top spray F, for waterborne paints, on trolley, with suction tube, w/o gun or hoses	
138958	SATA vario top spray FB-WS, mobile, with fine material pressure regulator, gravity flow cup w/o suction hose, 1 spray gun connection, w/o gun or hoses	

Note this is a special order item

Additional pumps and pressure pots on page 162-180

Errors, technical modifications and printing errors reserved.

Spare Parts SATA® vario top spray™

Order No./Desc.
17483 Trolley complete
19158 Pressure gauge 1-10 bar, 50 mm G 1/4 (0-150 psi)
19851 10-pk sieves
23986 Spray gun connection (air)
24240 Single pressure reducer w/ gauge 0-10 bars / 0-150 psi
74187 Suction globe complete, for waterborne materials
81604 Wing shaped handle
82107 Double pressure reducer, complete with gauge 0-10 bar / 0-150 psi
149716 6.0 l gravity flow cup with lid
149732 Container stud
149740 Sealing A 33 x l 23
149948 2-pk flat sieve 20 mesh

	Standard version	Stainless steel version
1	61192 Double diaphragm pump for SATA vario top spray, coated version	88641 Double diaphragm pump for SATA vario top spray, for waterborne paints, w/ material connection M 25 x 1.5 outside thread / G 1/4 outside thread
2	24422 Material fine pressure regulator, cpl., for SATA vario top spray	25338 Material fine pressure regulator cpl. for SATA vario top spray, all parts made of V2A stainless steel
3	72918 Spray gun connection (material) cpl.	57570 Spray gun connection (material) cpl. to material fine pressure regulator for second gun
4	62232 Suction hose complete for Top-Spray	45047 Suction hose cpl., for waterborne paints, for SATA vario top spray
5	73866 Ascending pipe cpl. w/ suction cap and sieve insert for SATA vario top spray	74203 Suction tube cpl., for SATA vario top spray, for waterborne paints, on trolley, w/ gravity flow container
6	79921 Suction tube cpl. w/ suction globe and sieve insert for SATA vario top spray	80879 Suction pipe cpl., for vario top spray mobile, w/o gravity recipient, for waterborne paints
7	74245 Sieve unit, mesh size 1.0, for SATA vario top spray, for waterborne paints	74237 Sieve unit, mesh size 0.5, for SATA vario top spray, for waterborne paints
8	8706 Nipple 1/2" x 1/2" BSP	82941 Double nipple G 1/2 outside thread, for sleeve ball tap, for SATA vario top spray, for waterborne materials
9	41368 Angle A 1, G 1/2 GF No. 90 galvanized version	56564 Angle 90 degree Rp 1/2 V2A, Wst.1.14436 for SATA vario top spray waterborne version
10	82909 Conversion set for gravity container SATA vario top spray	74211 Conversion kit for gravity flow container SATA vario top spray, for waterborne paints
11	37986 Add-on kit for 6 l plastic gravity container, complete with three-way ball tap and holder	37226 Add-on kit for 6 l plastic gravity container, cpl w. 3-way ball tap and holder

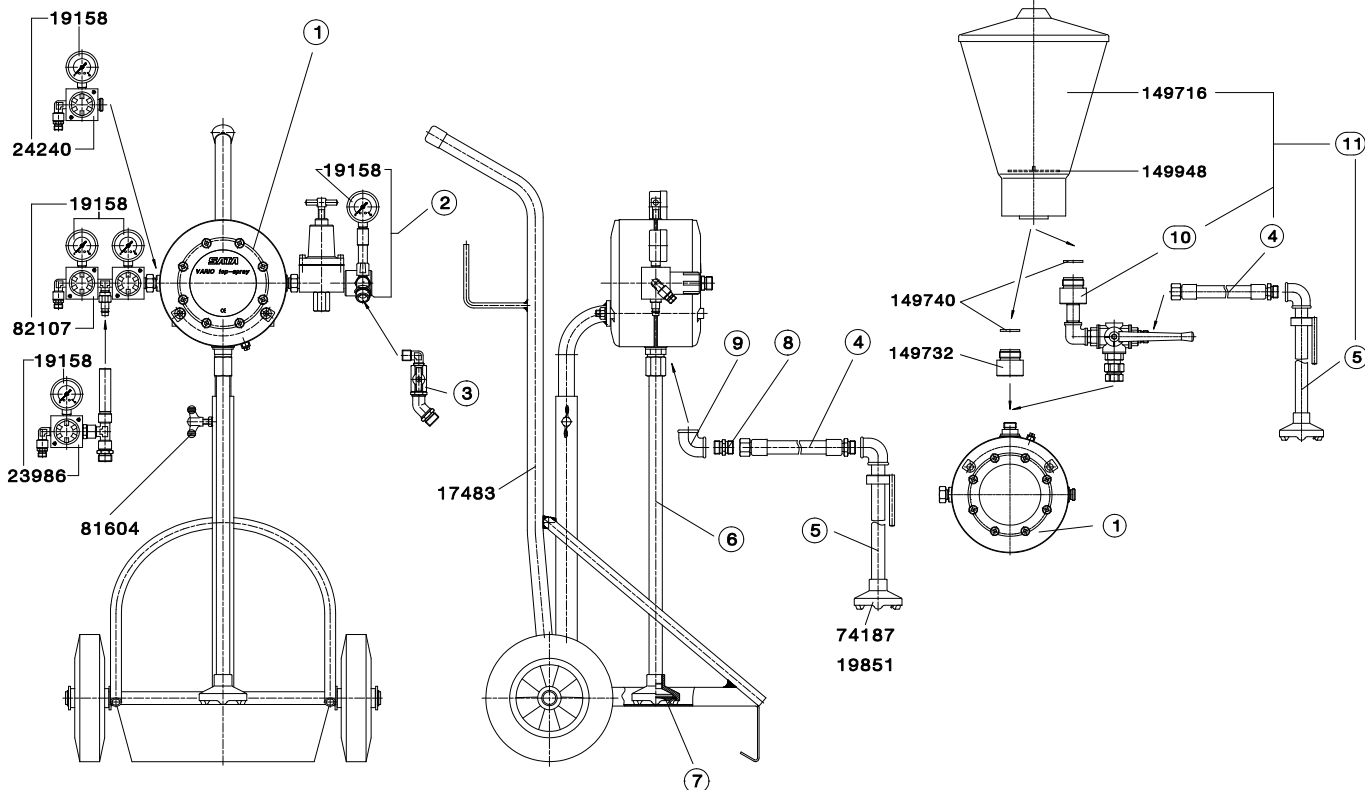

Errors, technical modifications and printing errors reserved.

Spare Parts SATA® vario top spray™ Pump

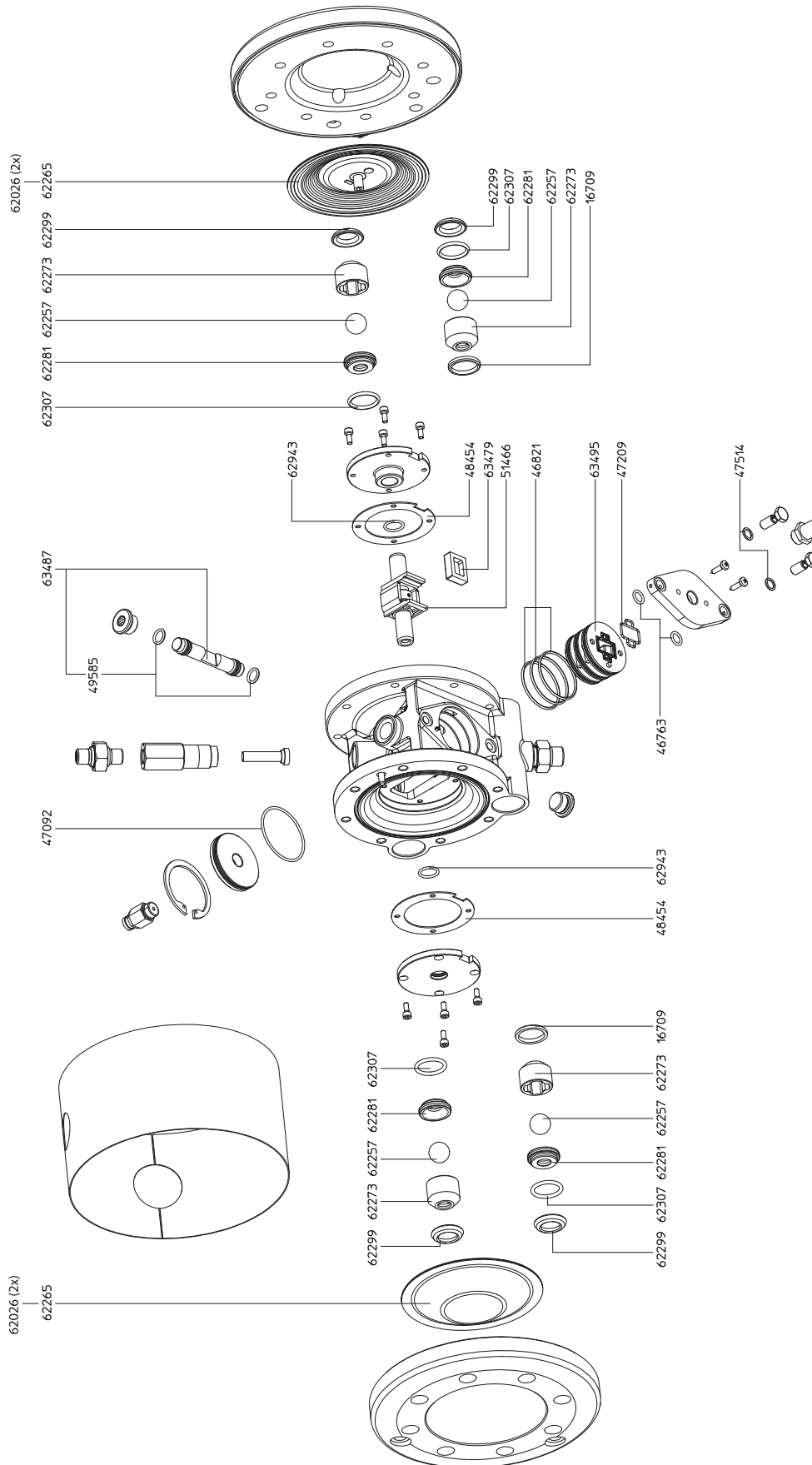

Spare Parts SATA® vario top spray™ Pump

Order No./Desc.	Kit
45195 Set of sealings, complete, for top spray double diaphragm pump	1
60012 Diaphragm repair kit for SATA vario top spray	2
60038 Control repair kit for SATA vario top spray	3
60228 Valve repair kit for SATA vario top spray	4
60301 Carrier rod repair kit for SATA vario top spray	5
60657 Carrier repair kit SATA vario top spray	6

We generally recommend using aforementioned seal and repair kits as well as exchanging all essential seals and components

Single components of the seal and repair kits

Order No./Desc.	Contained in the kit:
16709 Sealing for vario top spray industrial version	4
46763 O-ring 9 x 2 B for double diaphragm pump top spray	1 3 5
46821 O-ring 42 x 2 for double diaphragm pump top spray	1 3 5
47092 O-ring 48 x 2 for double diaphragm pump top spray	1
47209 Shape seal for double diaphragm pump top spray	1 3
47514 Sealing ring 8.2 x 11.4 x 1 for double diaphragm pump top spray	1 3 5
48454 Flat seal D 72 x T 1 for double diaphragm pump top spray	1 6
49585 O-ring 10 x 2 mm, made from Perbunan 10 shore	1
51466 Driving pin double diaphragm pump top spray	6
62257 Ball 18 mm for double diaphragm pump top spray	4
62265 Diaphragm complete D123 for SATA double diaphragm pump top spray	2
62273 Ball-bearing for double diaphragm pump top spray	4
62281 Valve seat D12 short for double diaphragm pump top spray	4
62299 Profile packing 17.2 x 28.2 x 5.4 for double diaphragm pump top spray	1 2 3 4 5 6
62307 O-ring 22 x 3 mm, FP 7010, for double diaphragm pump top spray	1 4
62943 O-ring 14 x 2 mm, Perbunan, for double diaphragm pump top spray	1 6
63479 Flat valve 24 x 19 mm, for SATA double diaphragm pump top spray	3
63487 Carrier rod D 13, 9L for SATA vario top spray, complete w/ O-ring 10.82 x 1.78	5
63495 Valve seal D 48 mm for SATA vario top spray double diaphragm pump	3

Errors, technical modifications and printing errors reserved.

Spare Parts Material Fine Pressure Regulator

Order No./Desc.	
7989	Ball tap (Teflon) with grip, without connection
21998	Pressure plate
22376	Compression screw
78766	Sleeve nut for material fine pressure reducer Vario-Top-Spray
78774	Insert part for material fine pressure regulator SATA vario top spray
78824	Pressure spring for material fine pressure regulator SATA vario top spray
78832	Tappet for material fine pressure reducer Vario-Top-Spray
80283	Diaphragm
80291	Tappet kit, cpl., for SATA material fine pressure reducer no. 80176
156026	Pressure gauge 0-6 bar, 50 mm, g 1/4, scale line each at 0.1 bar

Standard version 24422

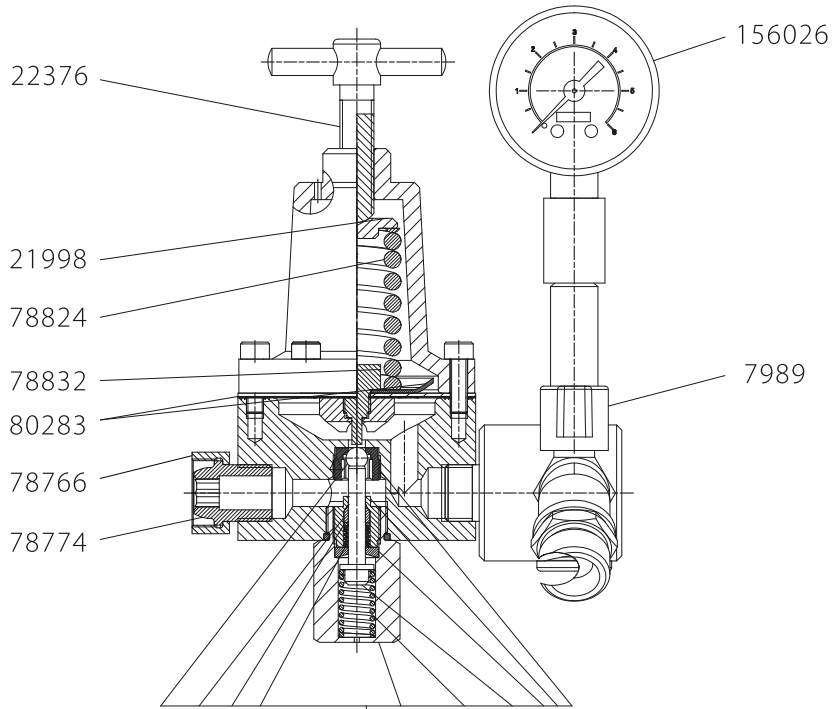

80291



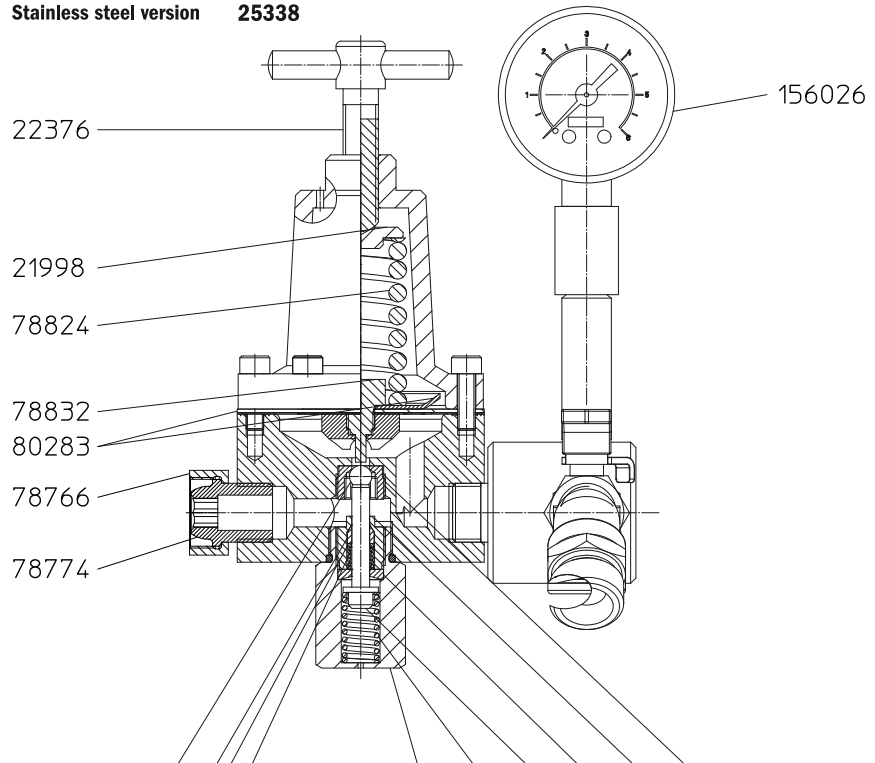





Stainless steel version 25338

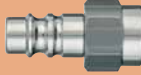

80291

Errors, technical modifications and printing errors reserved.

SATA® Quick Couplings

Individual components for the quick coupling system		
6981	SATA HVLP female nipple - 5-pk Quick coupling nipple G 1/4 female thread	
13656	SATA HVLP female nipple - Quick coupling nipple G 1/4 female thread	
53942	SATA HVLP male nipple - Quick coupling nipple G 1/4 male thread	
13599	SATA HVLP female QC - SATA quick coupling 100.14 G 1/4 female thread	
13623	SATA HVLP male QC - Quick coupling 100.14 G 1/4 male thread	
7237	Pack of 2 quick couplings, socket 9 mm, 2 quick coupling nipples G 1/4 female thread, 60 degrees cone.	
13508	Nipple for SATA quick coupling 104/38 G 3/8 male thread	
13557	Hose olive, 9 mm for air quick coupling	
13581	SATA quick coupling 101.38 G 3/8 female thread	
99895	SATA hose connection swivel	

Errors, technical modifications and printing errors reserved.

A close-up, grayscale photograph of a spray nozzle. The nozzle is positioned diagonally, and a fine mist of paint droplets is being emitted from its tip, creating a dense, textured pattern of small, rounded droplets. The background is a soft, out-of-focus gradient of light and dark tones, suggesting an industrial or workshop setting.

Dan-Am Co.
**Quality Paint Spray Equipment
and Accessories**

DanAmAir®

DanAm Air is,
Advanced Air Piping System for compressed dry and clean air.

For the professional, home, agriculture shops,
or anywhere you need clean, efficient air supply.



Easy to install yourself



***SAVINGS of over 50% compared to copper installation**



Measure & Cut • Push to Connect

DanAm Air's benefits;

- Energy efficient
- Lower installation costs
- Push-to-connect technology
- Immediate pressurization
- Removable and reusable
- Modular design
- No corrosion
- Leak-free guarantee
- Full bore design
- 1/2" - 6" pipe sizes

Easy Do-It-Yourself Installation

- No pipes to thread
- No soldering

DanAm Air is an aluminum compressed airlines that is easily installed with the push to connect technology, is modular, can be used and reused and connects to existing airlines.

Aluminum is an Efficient Alternative

DanAm Air offers a cost effective, innovative and energy efficient aluminum compressed air pipe system that is easy to assemble, change and expand. With DAA, self installation is easy. The materials and modular design of a DanAm Air air pipe system makes it quicker and less expensive to install than traditional systems. DanAm Air's aluminum piping is easier to lift and handle than standard steel piping. The push-to-connect fittings secure connections with a simple push, which is much quicker and safer than soldering copper.



For more information visit:
www.DanAmAir.com
and view our digital catalog

DAA is not only efficient, but also very clean looking, functional and modular so it can designed for use in any shop.

For a FREE quote call: 800-533-8016

*Savings may vary.

Renovate Your Steel System with DanAm Air

DanAm Air's aluminum pipe ensures a total absence of corrosion. The inner pipe surface consistently delivers clean compressed air. DanAm Air prevents the problems caused by rust, which affects galvanized steel systems. Due to consistent clean quality air, from compressor outlets to machines, DanAm Air's aluminum pipe ensures higher longevity of equipment and avoids frequent changes of filtration elements. DanAm Air can also be integrated into existing copper and steel piping without compromising performance, making it perfect for upgrades or expansion projects. DanAm Air's additional benefits include:



Significant Energy Savings

Compressed air represents one of the largest opportunities for immediate energy savings. Plant management is often surprised to hear that compressed air can represent 20-50% of a plant's electric bill. Plant management is truly amazed when they find out that using an efficient piping system specifically designed for compressed air can reduce their energy bill by 30-60%, many times within a 24-month period.

For instance, a large industrial plant recently redesigned their compressed air system with DanAm Air. This accounted for 35% savings in the plant's monthly energy bill, which paid for the system in 15 months. The plant continues to save by:

- Increased air system reliability
- Reduced maintenance cost and extended equipment life
- Reduced system downtime, increased production rates

The results speak for themselves and show that DanAm Air is the best performing system and the best long-term choice, no matter whether the project is for an extension, the modification of an existing pipe system or a new installation.



An Energy Efficient Solution



Savings Chart	DanAm Air	Threaded Carbon Steel	Copper
	Painted Alum.	Sch 40	Type L
Pipe Schedule			
Material			
Pipe	\$ 3,081.00	\$ 2,970.00	\$ 8,880.00
Fittings	\$ 1,727.00	\$ 642.00	\$ 481.00
Material Total	\$ 4,808.00	\$ 3,612.00	\$ 8,921.00
Labor Hours	22.35	82.21	60.42
Labor Cost at \$65/man hour	\$ 1,459.90	\$ 5,343.65	\$ 3,927.30
Total cost	\$ 6,267.70	\$ 8,955.65	\$ 12,848.30
DanAm Air			
Manhour Savings			
vs Threaded Carbon Steel	73%		
vs Copper	63%		
Total Installed Cost Savings			
vs Threaded Carbon Steel	30%		
vs Copper	51%		
MATERIAL LIST: 500 feet of pipe, 16 elbows, 7 tees, and 10 couplings (unions). Comparison is DanAm Air 1 1/2" (40mm) versus 2" pipe. Labor rates from MCAA manual are factored by 0.70, which is typical for estimating field jobs. Amounts subject to change without notice. Alterations Reserved			

For more information visit, DanAmAir.com

Carbon Monoxide Monitors

Carbon Monoxide Monitors

Ensures grade D air quality for booth and shop safety





Technical Data: X767 CO Monitor

Gas detected: CO in compressed air	Power: 110 volt AC
Detection Principle: 3 electrode electrochemical	Operating Temp: 30° - 120°
Calibration: preset to 10 ppm	Dimensions: 4" x 6" x 3.5"
Continuous lifetime operation	Weight: 4.2 lbs
Warranty: 2 years	Powered coated metal housing

Carbon Monoxide Monitor Versions

X767-PLUS	<p>110 volt AC Carbon Monoxide Monitor.</p> <p>Calibrated to 10 ppm with alarm and LCD display</p> <p>Meets 29 CFR 1910.134 requirements for CO monitoring of compressed breathing air.</p> <p>Audible and visual alarms for high CO or sensor failure.</p> <p>RFI filtered from interference of cell phones, two-way radios, etc.</p> <p>LCD digital readout in 1 ppm increments with response time of 10 seconds to 95%</p> <p>Proven reliable performance electrochemical sensor.</p> <p>Calibration recommended every 6 months.</p> <p>Remote alarm options available</p>	
-----------	---	---

Carbon Monoxide Monitor Accessories

X81-1231K	Calibration kit for Carbon Monoxide Monitor	
XA176	Standard 85 db remote alarm for Carbon Monoxide Monitor	
XA176A	Extra loud 100 db remote alarm for Carbon Monoxide Monitor	
XA176B	<p>Extra loud 120 db air horn w/ regulator for Carbon Monoxide Monitor</p> <p>Call for availability (this alarm only)</p>	
XA166	Siren alarm with strobe light	

X144 "ICOM" Individual Carbon Monoxide Monitor

X144	<p>"ICOM", Individual CO Monitor</p> <ul style="list-style-type: none"> ■ Mounts inside the respirator hood ■ Battery powered stand alone unit ■ Weighs less than 1 ounce <p>The battery powered X144 ICOM is a high performance, simple and effective tool for monitoring Carbon Monoxide. A control chip is factory set and programmed to alarm (76db) when the CO level in compressed air exceeds the OSHA standard of 10 ppm. Because it is so tiny, it mounts on the inside of the SATA vision 2000 supplied air respirator hood with a Velcro strip. The X144 ICOM is designed specifically to be affordable and easy to use in any shop. The X144 is small - only 2.4 x 1.4 x 0.6 inches and it weighs less than an ounce. Monitor accuracy is +/-10% of reading at standard conditions between 32° - 122°F. Normal operating life is one year and that can be extended by replacement of the battery and sensor.</p> <p>The instrument may also be returned annually for battery and sensor change at customer expense.</p>	
CR2450N	Battery replacement	

Spare parts Carbon Monoxide Monitors

Part Number	Description	Key #	X747	X757	X758	X767
13623	Male coupling, 1/4"			X		
13656	Female nipple, 1/4"			X		
1816-MC	Male coupling, 1/2" Milton			X		
1817-MN	Male nipple, 1/2" Milton			X		
84798	Plug, brass hollow hex 1/2"			X		
X06-1105	Air Tubing (per foot)	4	X		X	X
X07-6122	O Ring, sensor		X	X		X
X10-0279	Case screw, X758	1			X	
X14-A259	Screwdriver guide bushing			X		
X16-0285K	Bushing, 1/2" x 1/8", brass					X
X17-0001	Air inlet fitting, 1/8" MPT x 1/4" tube	5				X
X17-0005	Elbow fitting, 1/8" MPT x 1/4" tube					X
X17-0282K	Calibration gas inlet	13	X	X	X	
X17-0285	Flow restrictor, porous metal	7	X		X	
X17-6251K	Inlet fitting, straight w/porous plug	19			X	
X20-0110K	Case, calibration kit	14				X
X31-0003	Flow meter, replacement	3	X			
X35-6015K	Flow block	12				X
X43-0940	Switch, battery on/off					X
X45-2401K	Plug, repeater buzzer					X
X45-8012K	Battery housing, w/holder					X
X45-8013K	Battery holder					X
X47-1012K	Power cord (X767-PLUS only)	18				X
X47-4012K	Sensor wiring harness, X747		X			
X47-4120K	Sensor cable w/circuit board				X	X
X47-4156	Cord, 50' Buzzer extension					
X52-1020	Alarm buzzer	2	X			
X52-1051K	Alarm buzzer w/18' cable for remote breathing unit					X
X52-A279	Alarm Buzzer w/cable and plug	10				X
X57-A279	Circuit board, main	11				X
X65-2400K	Cell, CO detector	6	X	X	X	X
X81-0062K	Carbon Monoxide test gas cylinder, 10ppm			X	X	
X81-0065K	Carbon Monoxide test gas cylinder, 100ppm	17	X			X
X81-0078K	Nitrogen test gas cylinder 100%	15	X			X
X81-1001K	Regulator Valve	16	X	X	X	
X81-1051K	Calibration tube, w/monitor connection		X			
X81-1052K	Calibration tube, w/flow meter connection			X	X	X
X81-1230K	Calibration kit, X747 Carbon Monoxide monitor		X			
X81-1231K	Calibration kit, X767 Carbon Monoxide monitor					X
X81-1235K	Calibration kit, X757 & X758 CO monitor			X	X	
X82-0005K	Calibration screwdriver, jewelers			X	X	
X82-0091	Calibration screwdriver, dbl. ended		X			X

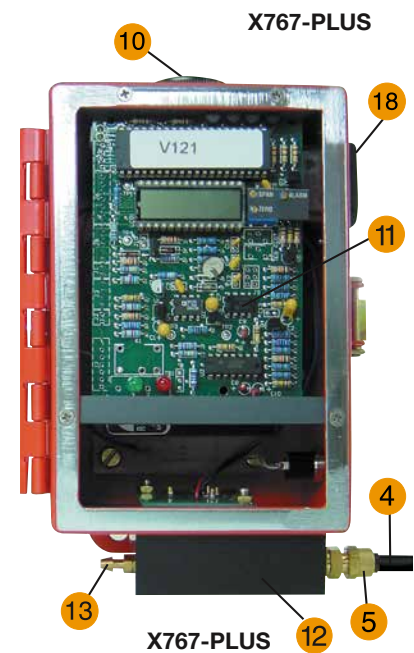

Calibration Kit

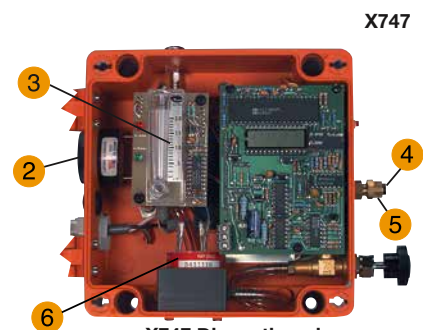

X747 Discontinued and Replaced with X767

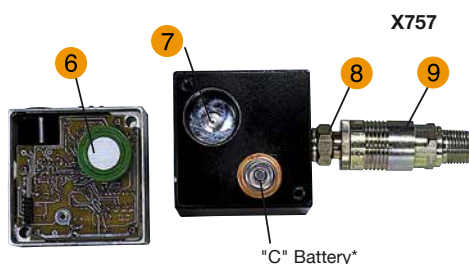



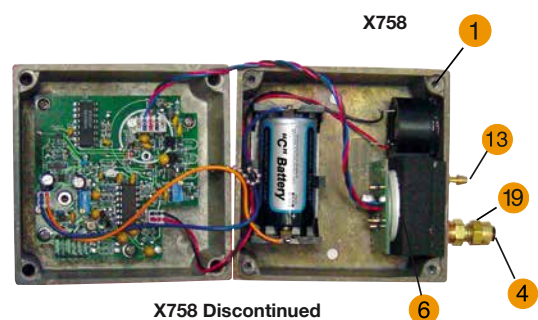





X757 Discontinued



X758 Discontinued
*PURCHASE BATTERIES LOCALLY

Errors, technical modifications and printing errors reserved

Dan-Am Accessories

Gun Cabinets		
95	<p>Large double door lockable gun cabinet</p> <p>Material: 20 gauge steel</p> <p>Storage: 2 shelves, locker, hangers for 7 gravity fed spray guns</p> <p>Measurements: 46 in w x 35 in h x 12 in d / 116 cm x 89 cm x 30.5 cm</p> <p>Must be shipped by truck, please call for a freight quote.</p> <p><u>FREIGHT CHARGES NOT INCLUDED</u></p>	
95	<p>Small single lockable gun cabinet</p> <p>Material: 20 gauge steel</p> <p>Storage: 1 shelf, and hangers for 7 gravity fed spray guns</p> <p>Measurements: 25 in w x 35 in h x 12 in d / 63 cm x 89 cm x 30.5 cm</p>	
9898-3A	Extra gun shelf holders are available that hold 3 guns or 4 guns. The shelves must be staggered in any order 4 gun or 3 gun so the spray guns are not resting on each other. Fits both cabinets	
9898-4	Cabinet three gun holder shelf	
	Cabinet four gun holder shelf	
Gun Holders		
9886	<p>Gun holder for SATAMinijet 3000 B HVLP</p> <p>Suitable for wall mounting, mounting in cabinet or mounting on a 9898 gun holder</p>	
9898-3	Wall mounted 3 gun holder	
9898-4	Wall mounted 4 gun holder	
9898-6	2 x wall mounted 3 gun holder, holds 6 guns total	
9890	<p>Dan-Am Company Bench Mounted Gravity Gun Holder With Built-in Strainer Holder</p> <p>Holds gravity gun perfectly straight for easy straining/refilling. Anodized black aluminum construction. Special plastic channel guide protects air cap horns. Screws to workbench.</p>	
9890-A	Special portable version with heavy metal base for on-site work (shown)	
9898-B	Metal base only	
SATA gun holders		
40188	SATA Wall or Bench Mount Heavy Duty Gravity Gun Holder. Red solvent resistant coating. Also works great for the SATA Mini-Jet. Gravity cup is held in the vertical position for easy refilling. Complete with mounting screws.	
9886	<p>SATA universal wall mount gravity gun holder.</p> <p>This type may be screwed to the wall at various locations for convenient storage.</p>	
10102	2-pk Hosemate hose guides made of durable plastic	
Electric Drain Valve		
640525 (1/4") 640533 (3/8") 640550 (1/2")	The EDV has been designed for general purpose applications. The unit is suited for all compressed air system components (after-coolers, dryers, filters, pressure vessels and piping), regardless of their size or capacity—simply adjust the interval and discharge times to suit the particular compressed air system. FPM seals for systems where synthetic lubricants are used are standard. 115 volt. 1 year warranty	

Dan-Am Accessories

DanAm Air Vac

DAA1001K

DanAm Air Vac removes foreign objects from wet paint/clearcoat. Eliminate dirt nibs, bugs, lint, hair or other airborne debris right after it lands.

The DAA Vac simply connects to your existing airline in the booth. Open the valve and the air creates a vacuum through the tool. Use the fine clear disposable tips to remove the debris from the wet paint/clearcoat, and use the disposable dropper to put a drop of paint/clearcoat back into the void. The paint/clearcoat will melt into the wet surface and you may have very light sanding and polish for perfection, if any at all.



Kit includes

- 1 DanAm Air Vac w/ball valve
- 1 4' suction hose w/tip
- 12 Tips, clear vacuum
- 1 Dropper

Parts for DanAm Air Vac

Position	Part No.	Description
1	DAA1001K	DanAm Air Vac complete
2	DAA1002T	Clear tips, disposable, 20 pk
3	DAA1003H	Black suction hose, 4'
4	DAA1004D	Dropper, disposable, 5 pk
5	DAA1005V	Ball valve
6	DAA1006BT	Tip, black hose, ea

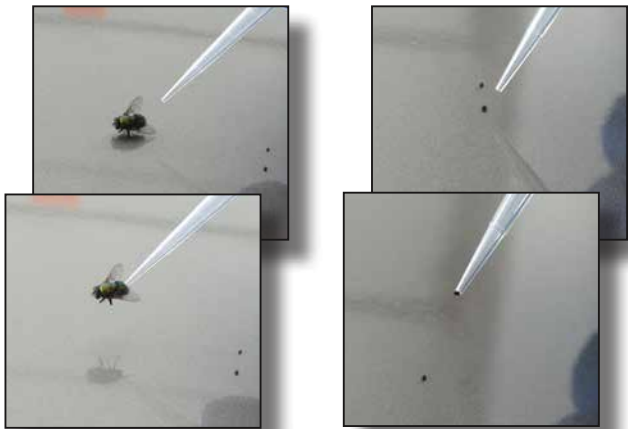

Errors, technical modifications and printing errors reserved

EASY-FLEX Panel /Paint Stand

Save Time, Money, and Work with Easy Flex

The FLEXIBLE stand was introduced more than 20 years ago with quality, stability and flexibility in mind with nothing left to chance. Approved and used by several car manufacturers, the FLEXIBLE paint stand saves time, money and makes the painters life easier. Virtually any panel may be painted inside and out in one operation.

Four flexible hook holders ensure a positive grip on the panel. The panel may be rotated to any angle up to nearly 360 degrees. No need to mask and unmask the car making the stand even more economical. Both sides of the panel may be primed or painted. When finished, the stand with the mounted panel can be baked - not the entire car. The FLEXIBLE stand is adjustable from 35 to 55 inches in height. Large, heavy-duty wheels make the stand easy to move about.

Several accessories are available including the Trim and Spoiler kit that allows threaded items to be mounted. Or with the Snap grip accessory, the painter can hang anything - and rotate it. The FLEXIBLE stand with wheels includes horizontal bar, two vertical bars, two vertical extensions, clamps and four mounting hooks. The stand is made of Electro-Galvanized steel and weighs slightly more than 26 lbs and holds up to 220 lbs.



EF190

MULTIFLEX I

MultiFlex I

Flexibility/Versatility

- Pivoting Multi-Directional Bumper Positioning
- Adjustable to nearly 360 degrees
- No pin locking
- Adjusts Vertically/Horizontally to fit any bumper of any size/shape etc
- 5 Securing Options:
 - Vice Grip & Support Plate
 - Vice Grip
 - Steel Wire
 - Strip/Tie Wrap
 - Nut & Bolt



- Maximizing efficiency and workflow
 Set up in a few seconds
 Adjustable during use, Entire Repair Process can be done with Bumper on Stand
 Can be used for smaller parts as well as Bumpers - using our small parts attachments
Like nothing else available! The Most Flexible, Versatile and Efficient Bumper Stand Anywhere!

EF150

MULTIFLEX II

MultiFlex II

Flexibility/Versatility

- Any Bumper Position to nearly 360 degrees
- Moves one handed
- No pin locking
- Stops and holds anywhere you need!
- Adjusts Vertically/Horizontally to fit any Bumper of any size/shape etc
- Quick Securing using Vice Grips - increasing efficiency and maximizing workflow
- Set up in a few seconds



Can be used for smaller parts as well as Bumpers - using our small parts attachments
Adjustable during use, entire repair process can be done using stand
More Flexible, Versatile and Efficient than any competing bumper stand in the US Market!

EF110

EASYFLEX

Easy Flex Paint Stand

Flexibility/Versatility

- Any panel position over nearly 360 degrees
- Moves one handed
- No pin locking
- Stops and holds anywhere you need!
- Adjusts Vertically/Horizontally to fit any panel of any size/shape etc



Any Panel and most bumpers - Really Universal!
 No need for additional stands for doors, hoods, or fenders, this takes them all!
 Unless a shop does a serious amount of bumpers this is the only stand they will need
 Can be used for smaller parts as well as panels - using our small parts attachments
Adjustable during use, entire repair process can be done using stand only
The Most Flexible, Versatile and Efficient Universal Panel Stand Anywhere!

Errors, technical modifications and printing errors reserved

Spare parts EF110 / EF150



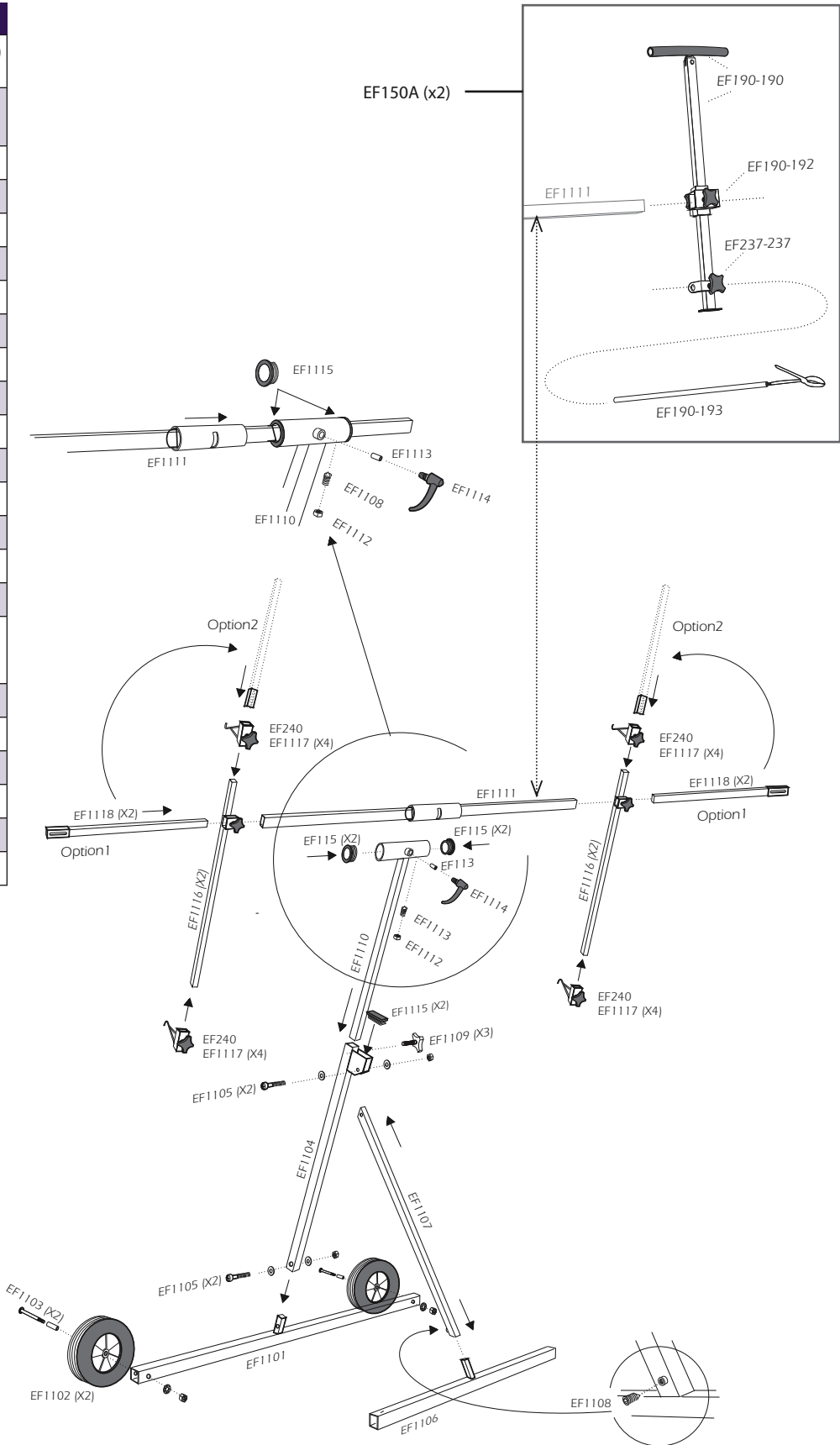







Order No./Desc.	
EF150A	Bumper arm kit (x2) Convert 110 to 150
EF240	Hook (single part)
EF1117	Hooks (4)
EF1101	Wheel Leg
EF1102	Wheels (2)
EF1103	Wheel Bolts (2)
EF1104	Leg Brace
EF1105	Frame Bolts (2)
EF1106	Leg
EF1107	Wheel Leg Brace
EF1108	Set Screws (2)
EF1109	Knob (3)
EF1110	Height Bar
EF1111	Cross Bar
EF1112	Counter Nut
EF1113	Brass Plug
EF1114	Locking Knob
EF1115	Cross bar seals(2), End plug (1)
EF1116	Tool Holder (2)
EF1118	Extensions (2)
EF190-190	Bumper arm w/pad
EF190-192	Dual arm clamp
EF190-193	Vise grip kit
EF237-237	Accessory clamp



Errors, technical modifications and printing errors reserved

EASY-FLEX panel /paint stand

Accessories for Easy Flex Paint Stand

EF200	<p>Trim and Spoiler Kit Includes 4 threaded rods for holding threaded accessories such as spoilers, mirrors, door handles etc, thread adapters and two mounting clamps.</p>		
EF215	<p>Squeeze-out Tension Clamp Kit Spring loaded pressure clamp spreads open to hold parts from the inside. Includes mounting clamp. Excellent for helmets!</p>		
EF250	<p>Motorcycle Tank Kit U-shaped hanger with outside lip, grips tank through the filler opening. A threaded eyebolt with counter nut locks gas tank hanger securely for easy painting. Kit includes a 16 1/2" extension bar</p>		
EF260	<p>Wheel Rim Holder Cone shaped design accommodates most any size wheel. The wheel holder mounts on the horizontal bar and locked down. Swivels 180°</p>		
EF270	<p>Locking pliers kit for securely fastening bumpers or other objects</p>		
EF275	<p>Snapgrip Kit Snapgrip mounted on rod firmly holds smaller items in place. Includes mounting clamp.</p>		
EF2300	<p>Xmas tree paint stand only 5 rod Used to mount 5 different mounting brackets that hold small parts for painting at one time</p>		
EF2400	<p>Xmas tree paint stand with 5 clamps 3) EF215 Squeeze-out Tension Clamps 2) EF275 Snapgrips</p>		
EF2303	<p>Xmas tree paint stand only, 3 rod Used to mount 3 different mounting brackets that hold small parts for painting at one time</p>		
EF2403	<p>Xmas tree paint stand with 3 clamps 1) EF215 Squeeze-out Tension Clamp 2) EF275 Snapgrips</p>		





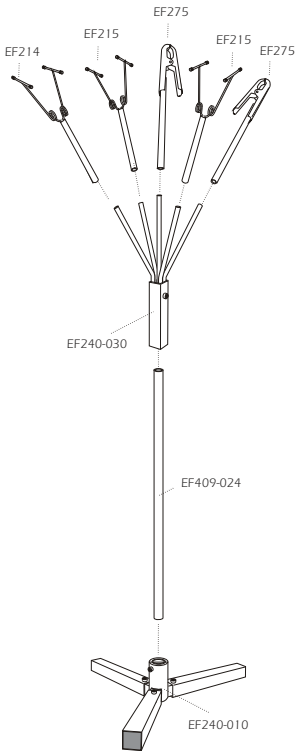
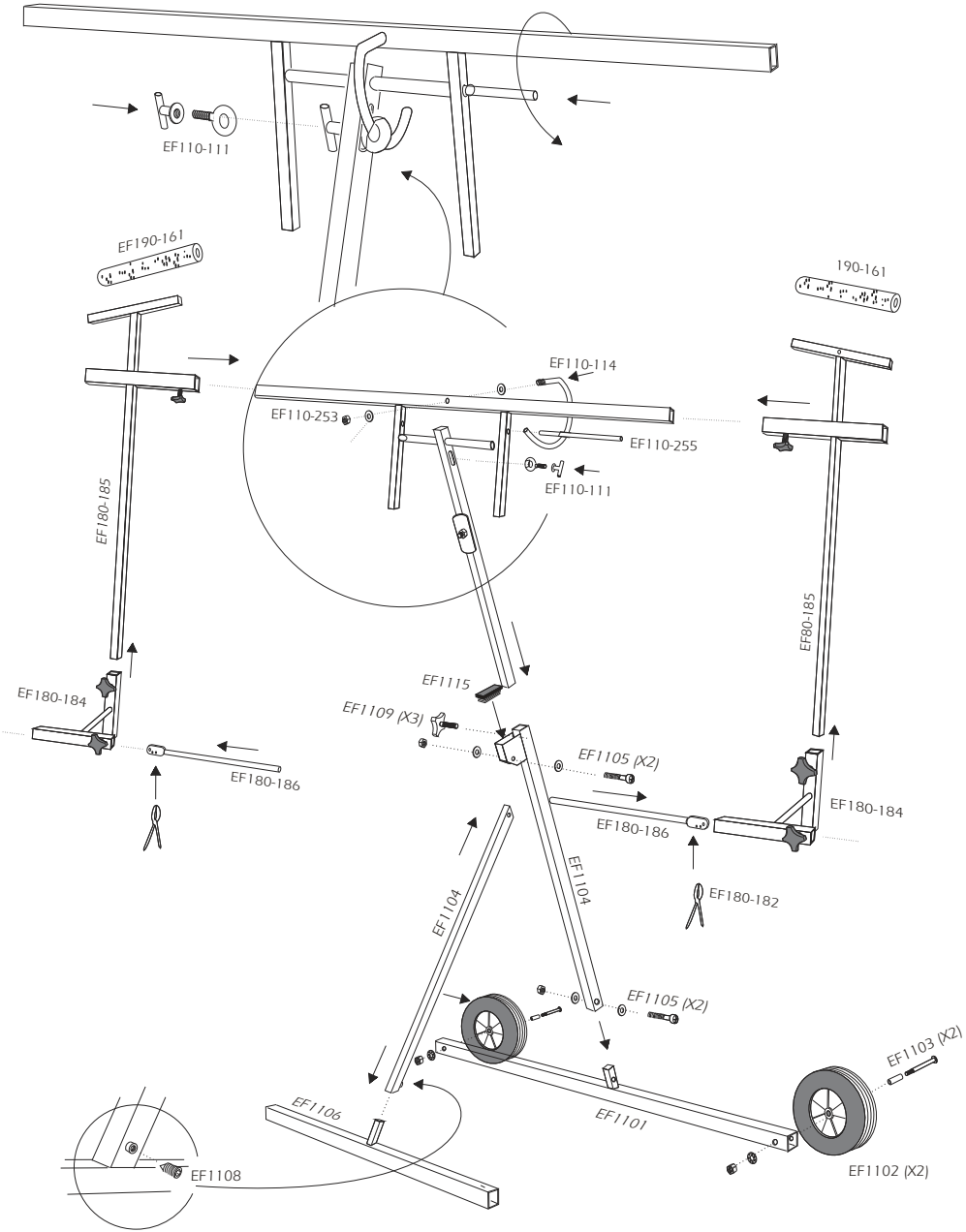





Parts EASY-FLEX panel / paint stand

Order No./Desc.	
EF215	Squeeze out clamp
EF240	Hook (single part)
EF240	Snapprip kit
EF1101	Wheel Leg
EF1102	Wheels (2)
EF1103	Wheel Bolts (2)
EF1104	Leg Brace
EF1105	Frame Bolts (2)
EF1106	Leg
EF1107	Wheel Leg Brace
EF1108	Set Screws (2)
EF1109	Knob (3)
EF1110	Height Bar
EF1111	Cross Bar
EF1112	Counter Nut
EF1113	Brass Plug
EF1114	Locking Knob
EF1115	Cross Bar (2), Leg (1)
EF1116	Tool Holder (2)
EF1117	Hooks (4)
EF1118	Extensions (2)
EF240-030	Xmas tree bracket holder
EF409-024	Xmas tree pole
EF240-010	Xmas tree base
EF190-161	Bumper pad (x2)
EF110-111	Tilt clamp
EF180-184	Bumper arm holder 90
EF180-185	Bumper arm
EF180-186	Bumper arm-vice grip
EF110-114	Tilt rod
EF110-255	Swivel rod center

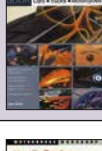

Errors, technical modifications and printing errors reserved

Dan-Am How-To Books and DVDs

How-To DVD's and Books		
CDMH1	<p><u>Beginning Airbrush Techniques for the Automotive Painter:</u> Gun control is essential to achieve professional results; this DVD will get you started right away. This DVD will show you what to practice to gain gun control. Learn the proper way to disassemble, clean and re-assemble your airbrush. Mickey will take you through a project rendering of a granite panel to demonstrate dimension. Approx. *** minutes</p>	
CDMH2	<p><u>Woodgrain Techniques</u> Mickey's fun loving and engaging teaching style will show you all the latest tricks for automotive woodgraining. Learn the fastest techniques to airbrush knots and knot holes, heavy woodgrain, barn wood, carvings in wood, and tongue and groove. Also cabinet doors and a boss hoss dash demo. Approx. *** minutes All the latest tricks and techniques for automotive WOODGRAINING!</p>	
CDMH3	<p><u>Prepare to Become a Master of Metal:</u> Mickey will show you techniques, tips, and tricks that will have you painting rivets and metal like a master. Topics covered in this DVD include a demo of the "Resident Evil" car and a Craftsman Series race truck. Mickey will also show you how to do rivets, dents, rips, grinder marks, and distressing. Approx. *** minutes</p>	
430151	<p>Kustom Painting Secrets by Jon Kosmoski Jon Kosmoski has once again teamed up with Tim Remus at Wolfgang Publications, Inc to produce a great new How-To book. He starts with the basics of how to set up a shop, pick a compressor and plumb in new airlines. He covers modern paint technology, and the right equipment to use. Full of great colored pictures of many of his own latest projects, and those of others. It is 144 pages containing a lifetime of Jon's Experience. This is a great book for any painter, and will be a great addition to any vocational schools must-read list.</p>	
MW140	<p>How to Paint Your Motorcycle by JoAnn Bortles, Author JoAnn Bortles covers the latest painting techniques; painting flames, skulls, and murals; candy and pearl paints; and also explains the latest paints and finishes. Even if you don't paint your own bike, this book will provide the information you need to have a professional painter do exactly what you want.</p>	
MW167	<p>How to Custom Paint Your Motorcycle by JoAnn Bortles Author JoAnn Bortles teaches the art of motorcycle painting from top to bottom, from matte black to candy coats, metallic, marblizing, granites, and more. Bortles explains bodywork and molding techniques, setting up your paint area, buying and maintaining your equipment, and choosing the correct paints and finishes</p>	
MW222	<p>How to Custom Paint Your Car by JoAnn Bortles Whether you're flaming a hot rod, putting skulls on a classic lowrider, or simply coating your automobile in a shiny pearl or candy, this book will walk you through every step of the process. Step-by-step, learn how to set up your workshop, choose your tools, and prep your car. Then, from simple to the extraordinary, start working with custom colors, flames, metallic, marbles, custom graphics, and pinstriping</p>	
MW237	<p>How to Master Airbrush Painting Techniques by JoAnn Bortles Expert custom painter and author JoAnn Bortles takes the beginner through the first steps of becoming an airbrush artist. She starts by explaining how to choose and buy equipment, how to master strokes and air pressure, and the materials and accessories a painter will need. And when you're ready to move on to portraits, metal effects, complex stencils, landscapes and more, Bortles gives you the tools to tackle more difficult projects.</p>	
145419	<p>How To Custom Paint Cars, Trucks and Motorcycles by JoAnn Bortles If you're planning a custom build or a new paint job for your favorite ride, this is the place to start. Award-winning painter and author JoAnn Bortles has compiled over 750 photos of dazzling custom paint jobs and drawing on first-hand experience, JoAnn explains the nature of color, graphic patterns, what's pleasing to the eye and what isn't, and how to make the right choice in custom paint.</p>	
Paintable Mini Hoods		
HOOD	Ready to paint, miniature aluminum hood. Approx. size: 24" w x 30" h	
HOODM	Mini-Mini hood, DanAm aluminum miniature hood ready for painting, little smaller than the miniature hood above Approx. size: 14.75" w x 13.10" h	
		

Dan-Am Paint Suits

Dan-Am Paint Suits

The Dan-Am **Pro-Series** paint suit is expertly designed for fit and movement, with sewn in Carbon Fibre Thread to dissipate electro-static charges which cannot wash out. Made with the finest quality fabric and specially treated to keep it lint free. Comes with the special Mike Elwood design SATA Twisted Fire on the back and SATA spray gun logo on the front. The suit has a covered heavy duty zipper, interior utility pocket, adjustable sleeve and leg velcro closures, wide leg, adjustable elastic waste band for fit and comfort, fully breathable back fabric, 2 utility back pockets, underarm zipper opening for ventilation when needed, bi-swing shoulders for easier movements. Machine washable. *Outperforms disposable coveralls and outlasts them at least ten to one.*

tSGS Tested, ATCC118-2007, Grade 8

(Download SGS test report from www.satausa.com)



Pro Series Dan-Am Paint Suit

510050PS	X-Small
510052PS	Small
510054PS	Medium
510056PS	Large
510058PS	XLarge
510060PS	XXLarge (2XL)
510062PS	XXXLarge (3XL)

Please Note: Order the Pro-Series paint suit as you would your normal size, these run a little larger to fit over your clothing.

Dan-Am Paint Suits

Dan-Am Company offers this high quality paint suit with SATA logo on the front and back. They are made of 100% breathable polyester that offers superior protection over clothing. These paint suits are treated to be anti-static, open at the wrist, ankle and face, available in white or gray. The Dan-Am paint suits are machine washable and available in sizes X-Small to 4XL.

White Dan-Am Paint Suit

530050W	X-Small
530052W	Small
530054W	Medium
530056W	Large
530058W	XLarge (XL)
530060W	XLarge (2X)
530062W	XXXLarge (3X)
530064W	XXXXLarge (4X)



Gray Dan-Am Paint Suits

510052	Small paint suit
510054	Medium paint suit
510056	Large paint suit
510058	X-Large paint suit
510060	XX-Large paint suit
510062	XXX-Large paint suit
510064	XXXX-Large paint suit



***Please Note:** This chart is a guide for Dan-Am Paint Suit. Proper fit varies with under clothing and body shape. We recommend ordering *one size larger* after locating your size on the chart.

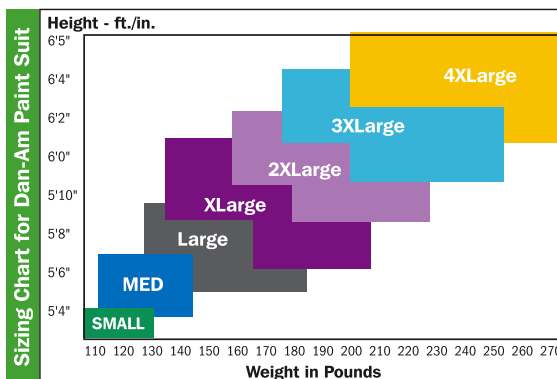

Errors, technical modifications and printing errors reserved

SATAwear

Part No	Sizes
T-XS	Extra small
T-S	Adult small
T-M	Adult medium
T-L	Adult large
T-XL	Adult x-large
T-XXL	Adult 2x-large
T-XXXL	Adult 3x-large



Dan-Am /SATA shirts and accessories

BLACK "Twisted Fire" SATA T-SHIRT

This is a one-of-a-kind and limited edition T-shirt was designed by Mike Ellwood of Twisted Designs Airbrush Studio for SATA Spray Equipment/Dan-Am Co. Has a large Twisted fire artwork on back and small SATA logo on front. Shirts are available in black only.
 100% cotton pre-shrunk.



Part No.	Size
TB-S	Adult Small
TB-M	Adult Medium
TB-L	Adult Large
TB-XL	Adult XL
TB-2XL	Adult XXL
TB-3XL	Adult 3XL

MEN'S Short sleeve Tradition gray polo shirt

The Tradition by Tri-Mountain is a softer, less textured fabric, this subtle drop needle vertical stripe is a classic. The 7.5 oz. 60% cotton/40% polyester blend ensures easy care and great performance. Features a tipped collar, three horn buttons and a half-moon yoke back. Clean-finished placket, bottom hem with side vents. With the SATA logo embroidered on the front chest and the DanAm Air logo on the sleeve.



Part No	Standard Sizes
P-S	Adult small
P-M	Adult medium
P-L	Adult large
P-XL	Adult x-large
P-2XL	Adult 2x-large
P-3XL	Adult 3x-large

Part No.	Tall Sizes
P-TL	Adult tall large
P-TXL	Adult tall x-large
P-T2XL	Adult tall 2x-large
P-T3XL	Adult tall 3x-large

SATAwear & Accessories

Dan-Am /SATA shirts and accessories

MEN'S TWILL WITH STAIN RELEASE

55% cotton/45 polyester twill wovens with stain release. Horn-style buttons. Extra stitching for strength at seams and buttons. Flat felled seam finishing. Full back yoke and back pleat. Colors: White and Stone. Sizes: M, L, XL, 2X



Always check for availability

Part No. White		Part No. Stone	
SW-HRRM500S-M	Adult medium white	SW-HRRM500SS-M	Adult medium stone
SW-HRRM500S-L	Adult large white	SW-HRRM500SS-L	Adult large stone
SW-HRRM500S-XL	Adult x-large white	SW-HRRM500SS-XL	Adult x-large stone
SW-HRRM500S-2X	Adult 2x-large white	SW-HRRM500SS-2X	Adult 2x-large

MEN'S LONG SLEEVE OXFORD WITH STAIN RELEASE

65% cotton/35% polyester oxford with stain release. Easy care. Pearlized buttons. Extra stitching for strength at seams and buttons. Flat felled seam finishing. Full back yoke and back pleat. Colors: Light blue and French blue.



Always check for availability

Part No. Light Blue		Part No. French (dark) blue	
SW-HRRM600LB-M	Adult medium white	SW-HRRM600FB-M	Adult medium stone
SW-HRRM600LB-L	Adult large white	SW-HRRM600FB-L	Adult large stone
SW-HRRM600LB-XL	Adult x-large white	SW-HRRM600FB-XL	Adult x-large stone
SW-HRRM600LB-2X	Adult 2x-large white	SW-HRRM500SS-2X	Adult 2x-large

Golf balls

SW-7004	SATA ULTRA GOLF BALLS Sleeve of 3	
---------	---	---

Caps and Beanies





CAP	Camo Cap	
SCAP	Camo Fleece Beanie	

Errors, technical modifications and printing errors reserved

Dan-Am Pro Stencils

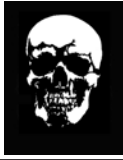
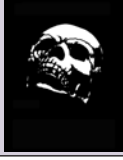
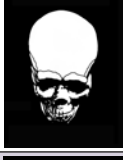
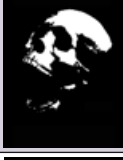

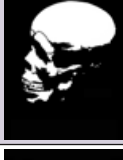
Dan-Am Pro Skull Stencils

Dan-Am Pro Skull stencils are made to PAINT OVER DARK DARK COLORS.

T1	Skull pack 1 Five different sizes	
T2	Skull pack 2 Five different sizes	
T3	Skull pack 3 Five different sizes	
T4	Skull pack 4 Five different sizes	
T5	Skull pack 5 Five different sizes	
T6	Skull pack 6 Five different sizes	
T7	Skull pack 7 Five different sizes	
T8	Super Skull pack This contains 35 stencils. Five different sizes of each, T1, T2, T3, T4, T5, T6, T7	

Dan-Am Pro Texture Stencils

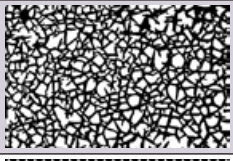
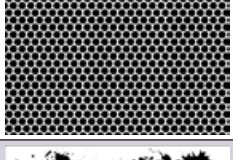
Dan-Am Pro Texture stencils,
Each supplied in 2 sizes.

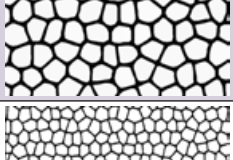
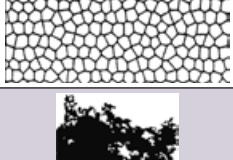
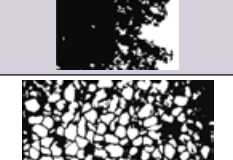
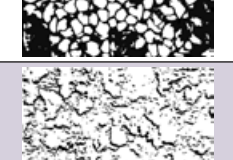
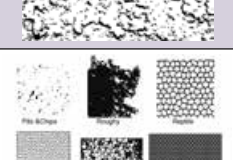
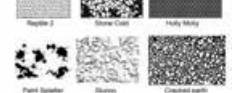
T9	Cracked earth 2 Stencils Approx. size 1) 4" x 5" 1) 8" x 10"	
T10	Holly Molly 2 Stencils Approx. size 1) 4" x 5" 1) 8" x 10"	
T11	Paint Splatter 2 Stencils Approx. size 1) 4" x 5" 1) 8" x 10"	
T12	Pits & Chips 2 Stencils Approx. size 1) 4" x 5" 1) 8" x 10"	
T13	Reptile 2 Stencils Approx. size 1) 4" x 5" 1) 8" x 10"	
T14	Reptile 2 2 Stencils Approx. size 1) 4" x 5" 1) 8" x 10"	
T15	Roughy 2 Stencils Approx. size 1) 4" x 5" 1) 8" x 10"	
T16	Stone Cold 2 Stencils Approx. size 1) 4" x 5" 1) 8" x 10"	
T17	Stucco 2 Stencils Approx. size 1) 4" x 5" 1) 8" x 10"	
T18	Mega Texture Kit 18 Stencils One SET of each; T9, T10, T11, T12, T13, T14, T15, T16, T17	

Errors, technical modifications and printing errors reserved

Dan-Am Pro Stencils

Freehand stencils

Dan-Am Pro freehand stencils and paint masking paper

T19	Necessary Nine, freehand stencil kit	
-----	--------------------------------------	---

Paint Masking

MH4075	Sticky Mickey's Original paint masking paper. 10" x 150'	
--------	---	---

Errors, technical modifications and printing errors reserved

Sales and Demo Support

Salesman Ultimate Demo Carrying Case

High-impact Hardigg Storm Case, with retractable pop-up handle and wheels that make it easy to transport. It is watertight, has three comfort grip carrying handles and features press and pull latches. There are 2 different inserts, one for automotive spray guns and accessories and an industrial model that will hold a pressure pot, spray guns and accessories. This attractive case is gray and weighs 19 lbs empty. Measures 19.7" W x 24.6" L x 11.7" H. The SATA Hardigg demo case is sold EMPTY, you specify how to equip it.



IM2720	Demo case with automotive or industrial insert. Please specify insert when ordering.
--------	---

Equipment NOT included

Must request Auto or Industrial case insert

IM2720
Auto Insert



IM2720
Industrial
Insert



Salesman 4 Gun Demonstration Case

Compact aluminum case for jobber salesman, sales rep., or the painter. Compartments for up to 4 SATA spray guns with Sata Adam 2 docks attached, and gravity paint cups. Other compartments for SATA accessories. Locking latch type case with black handle.

Overall size measures 18 W x 13½ D x 6 H. The aluminum case is sold EMPTY. Specify how to equip it.

131045	Aluminum case with foam insert.
--------	---------------------------------

Equipment NOT included



Portable SAMS Unit

An ideal system for paint techs, demo salesmen and shops that require a portable supplied air monitoring system. It contains everything necessary to monitor Grade D air - all in a neat Hardigg Storm Case. This quality case features pop-up handles and wheels for easy portability. The unit includes a two or three stage filter depending on the type of belt unit chosen, the battery powered X144 CO monitor, vision 2000 supplied air respirator, 6' ½ inch ID connecting hose, all hardware and 50 feet Premoflex non-gassing breathing air hose.

2720-244	As described above but with 2-stage filter and vision 2000 supplied air respirator with charcoal belt unit.
----------	---

2720-284	As described above but with 3-stage charcoal filter and vision 2000 supplied air respirator with industrial belt valve.
----------	---







Dan-Am Hoses

Air Hoses - for use with supplied air respirators and spray guns

55640	52 in / 1.3 m paint whip hose - to connect SATA spray gun and belt unit	
3366-15	15 ft / 4.6 m Premoflex non-gassing hose - 3/8 in ID w/ 1/4 in NPT male fittings	
3366-25	25 ft / 7.6 m Premoflex non-gassing hose - 3/8 in ID w/ 1/4 in NPT male fittings	
3366-35	35 ft / 10.7 m Premoflex non-gassing hose - 3/8 in ID w/ 1/4 in NPT male fittings	
6633-50	50 ft / 15.3 m Premoflex non-gassing hose - 3/8 in ID w/ 1/4 in NPT male fittings	
6633-60	60 ft / 18.3 m Premoflex non-gassing hose - 3/8 in ID w/ 1/4 in NPT male fittings	
6633-75	75 ft / 22.8 m Premoflex non-gassing hose - 3/8 in ID w/ 1/4 in NPT male fittings	
6633-100	100 ft / 30.5 m Premoflex non-gassing hose - 3/8 in ID w/ 1/4 in NPT male fittings	



High Quality Combination Hoses for 2 - 40 l Pressure Tanks and 1:1 Pumps

675206	6 ft dual hose - 3/8" air hose, 1/4" material hose, female fittings	
675215	15 ft dual hose - 3/8" air hose, 1/4" material hose, female fittings	
675225	25 ft dual hose - 3/8" air hose, 1/4" material hose, female fittings	
675250	50 ft dual hose - 3/8" air hose, 1/4" material hose, female fittings	
675406	6 ft dual hose - 3/8" air hose, 3/8" material hose, female fittings	
675415	15 ft dual hose - 3/8" air hose, 3/8" material hose, female fittings	
675425	25 ft dual hose - 3/8" air hose, 3/8" material hose, female fittings	
675450	50 ft dual hose - 3/8" air hose, 3/8" material hose, female fittings	
675510	10 ft combination hose for SATAminijet 3000 PT, 1/4" air hose, 6mm material tubing, female fittings (SATAminijet 3000 PT only)	
675706	6 ft combination hose for SATAminijet 1000 K (only), 1/4" air hose, 6mm material tubing, female fittings	
675710	10 ft combination hose for SATAminijet 1000 K (only), 1/4" air hose, 6mm material tubing, female fittings	
675715	15 ft combination hose for SATAminijet 1000 K (only), 1/4" air hose, 6mm material tubing, female fittings	
675725	25 ft combination hose for SATAminijet 1000 K (only), 1/4" air hose, 6mm material tubing, female fittings	

High Quality Combination Hoses for High Pressure Pumps

640225	25 ft / 7.6 m dual hose - 1/4" air hose, 3/16" material hose, female fittings	
640250	50 ft / 15.3 m dual hose - 1/4" air hose, 3/16" material hose, female fittings	

Air and Combination Hoses for SATAminijet 3000 B, SATAgraph 1, 2, 3 & 4, SATAjet 20 B

32987	9.8 ft / 3 m x 4 mm PVC compressed air hose for SATAgraph and SATAjet 20 B	
S040	6 ft braided hose, 1/8" X 1/4"	
S041	10 foot braided air hose 1/8" X 1/4",	
S042	6 ft braided hose w/moisture trap	
S045	8 ft braided hose w/quick disconnect (shown)	
54353	6.5 ft / 2 m clear PVC compressed air hose for SATAminijet and SATA 20 B. 6 ID x 1/4 female fittings	

For fittings and couplers please see page 141

* Custom hose lengths available - Please call for quote*

Dan-Am Pressure Pots

2.0L pressure pots

Pressure tanks are a system for direct material storage and delivering a continuous pressurized material flow to the spray gun. A pressure tank system offers the advantages of large surface performance, low weight of the spray gun and continuous operation without refilling. Dan-Am pressure tanks are supplied complete with pressure regulator and over pressure valve. Conventional or HVLP guns may be used with pressure tanks.

2.0L pressure pot - Aluminum

670200 Dan-Am 2 liter aluminum pressure pot, complete with deck, regulator and tank



2.0L pressure pot - Stainless Steel

670400 Dan-Am 2 liter stainless steel pot, complete with deck, regulator and tank



Technical

Specifications	Std Version	SS Version
Max Cup Pressure	50 psi/3.5 BAR	50 psi/3.5 BAR
Max Operating Pressure	35 psi/2.4 BAR	35 psi/2.4 BAR
Overall Height	17 3/4" / 450 mm	19" / 485 mm
Base Diameter	5 1/8" / 130 mm	5 1/8" / 130 mm
Air Inlet	1/4 NPS male	1/4 NPS male
Air Outlet	1/4 NPS male	1/4 NPS male
Material Outlet	3/8 NPS male	3/8 NPS male
Fluid Capacity	2.1 qt/2 Liter	2.1 qt/2 Liter
Weight	3 lbs 14 oz/1.76 kg	5 lbs 8 oz/2.5 kg

Hoses page 161

2.0L Aluminum Pressure tank w/Sata Spray gun and 6 ft dual hose

Spray gun/Nozzle size	.05	0.8	1.0	1.1	1.2	1.3	Specify different nozzle
SATAjet 3000 K HVLP	—	670260	670296	—	670298	—	670296
SATAjet 3000 K RP	—	670293	—	670294	—	670295	670294
SATAjet 1000 K HVLP	—	670260	670261	—	670262	—	670260
SATAjet 1000 RP	—	670265	—	670266	—	670267	670265
SATAminijet 1000 K HVLP	670270	670271	670272	—	670273	—	
SATAminijet 1000 K RP	670275	670276	670277	—	670278	—	

Includes: 1) Spray gun, 1) 670200, 2.0L aluminum pressure pot, 1) Stainless steel paint pipe, 1) 6ft dual hose

Spare Parts Dan-Am Pressure Pots

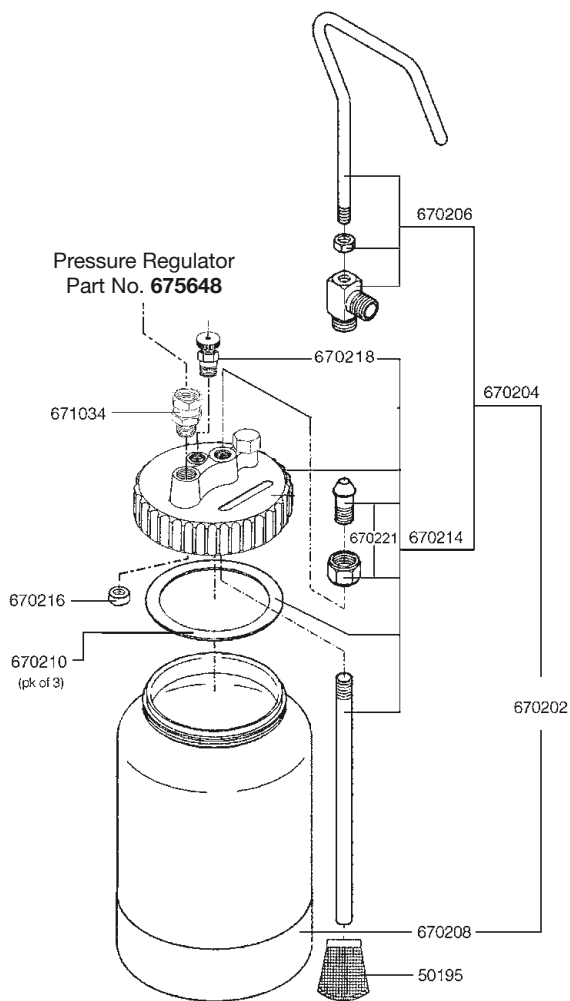

670200 Aluminum 2.0L pot

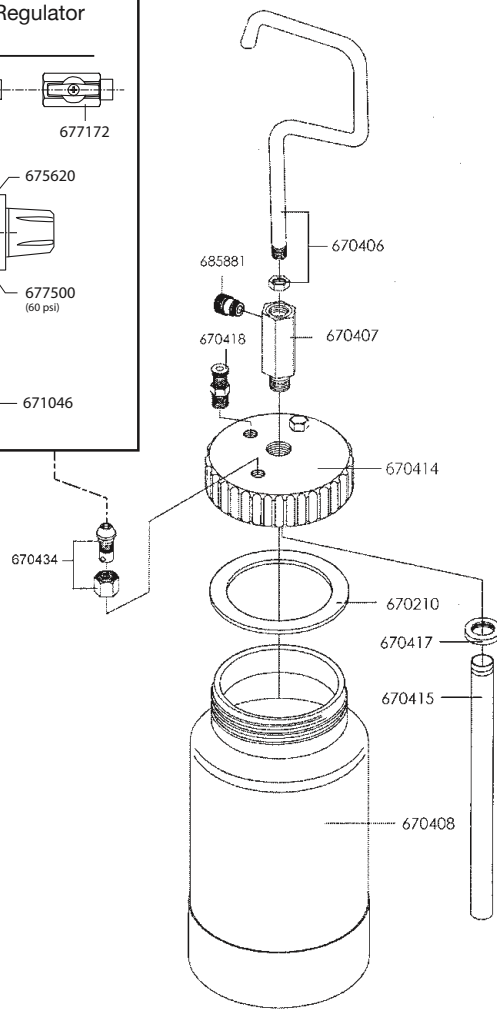
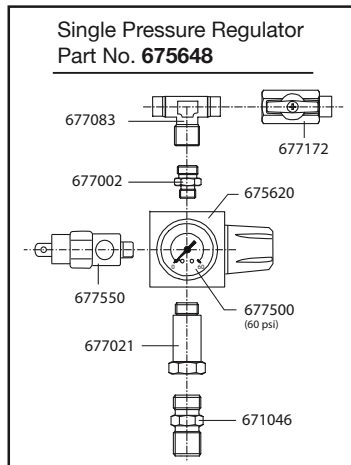

670400 Stainless Steel pot

670200 Aluminum 2.0L pot	
50195	Sieve, pk of 2 (optional)
670202	Pot complete w/o regulator
670204	Deck complete w/o regulator
670206	Material outlet/handle assem.
670208	Pressure cup, 2 liter
670210	Deck gasket, pk of 3
670214	Deck Assembly
670216	Check valve insert (optional)
670218	Pressure release valve
670219	Viton O-ring for 670218
670221	Material outlet fitting
671046	Check valve
675620	Regulator body, 1/4"
677002	Male hex nipple, 1/4"
677021	Extension, 1/4"
677062	Street elbow, 1/8"
677063	Street elbow, 1/4"
677083	Tee fitting, 1/4"
677172	Mini ball valve, 1/4"
677500	Gauge, 1-1/2", 60 psi
677550	Over pressure valve, 35 psi
675648	Regulator assembly, complete

670400 Stainless Steel 2.0L pot	
670400	Pressure pot cpl., w/regulator
670406	Handle w/nut
670407	Material outlet
670408	Tank only
670414	Deck only
670415	Fluid pick-up tube
670417	Nut, fluid pick-up tube
670418	Pressure release valve
670430	Regulator assembly, complete
670434	Air inlet fitting
671046	Check valve
671046	Check valve, 1/4"
671050	Regulator repair kit
675620	Regulator body, 1/4"
675648	Regulator assembly, complete
677002	Male hex nipple, 1/4"
677021	Extension, 1/4"
677083	Tee fitting, 1/4"
677172	Mini ball valve, 1/4"
677500	Gauge, 1-1/2", 60 psi
675648	Regulator assembly, complete
685881	Material outlet fitting

Use for pots with serial number above 2-00001

Errors, technical modifications and printing errors reserved

Dan-Am 10 - 20 Liter Pressure Tanks

10 - 20 Liter Pressure Tank

Dan-Am Company offers a quality line of pressure tanks from 10 to 40 liter. These cost-effective tanks are supplied complete with a quality regulator, over-pressure valve, back-check valve and fluid shut-off valve. Dan-Am models include 10 liter pressure tanks with single or double pressure regulator either plain, with manual stirrer or with pneumatic stirrer. Other 20 and 40 liter variations are also offered with single or double pressure regulator. Tanks are mounted on wheels for ease of handling and mobility.

10 Liter pressure tank

671100	10 l pressure pot w/ single regulator, over-pressure valve, back check valve, fluid shut off valve w/o stirrer	
681100	10 l pressure pot w/ double regulator, over-pressure valve, back check valve, fluid shut off valve w/o stirrer	
671200	10 l pressure pot w/ single regulator, over-pressure valve, back check valve, fluid shut off valve and manual agitator	
681200	10 l pressure pot w/ double regulator, over-pressure valve, back check valve, fluid shut off valve and manual agitator	
671300	10 l pressure pot w/ single regulator, over-pressure valve, back check valve, fluid shut off valve and pneumatic agitator	
681300	10 l pressure pot w/ double regulator, over-pressure valve, back check valve, fluid shut off valve and pneumatic agitator	

20 Liter pressure tank

682100	20L pressure pot w/ double regulator, over-pressure valve, back check valve, fluid shut off valve w/o stirrer	
672200	20L pressure pot w/ single regulator, over-pressure valve, back check valve, fluid shut off valve and manual agitator	
682200	20L pressure pot w/ double regulator, over-pressure valve, back check valve, fluid shut off valve and manual agitator	
672300	20L pressure pot w/ single regulator, over-pressure valve, back check valve, fluid shut off valve and pneumatic agitator	
682300	20L pressure pot w/ double regulator, over-pressure valve, back check valve, fluid shut off valve and pneumatic agitator	

40 Liter pressure tank

674300	40L pressure pot w/ single regulator, over-pressure valve, back check valve, fluid shut off valve and pneumatic agitator	
684300	40L pressure pot w/ double regulator, over-pressure valve, back check valve, fluid shut off valve and pneumatic agitator	

Accessories for pressure tanks

671012	10L Pressure tank disposable liner, 12 pack	
671060	10L Pressure tank disposable liner, 60 pack	
672012	20L Pressure tank disposable liner, 12 pack	
672024	20L Pressure tank disposable liner, 24 pack	

See page 161 for hoses

Spare Parts Dan-Am 10 Liter Pressure Tank

Order No./Desc.	
671001	Pressure tank, 10 L
671002HD	Wheel assembly
671003	Swing bolt assembly
671004	Fluid tube
671005	Fluid sieve kit
671006	Tank lid
671007	Lid gasket
671008	Handle
671009	Pressure relief valve
671010	Secondary over pressure release valve
671011	Fluid Valve Assembly, single
671012	Disposable liner, 10L, Pk of 12
671034	Swivel Connector, Male/Female
671060	Disposable liner, 10L, Pk of 60
671071	Fluid outlet
671072	Fluid sieve housing

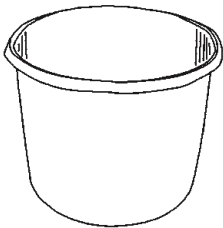
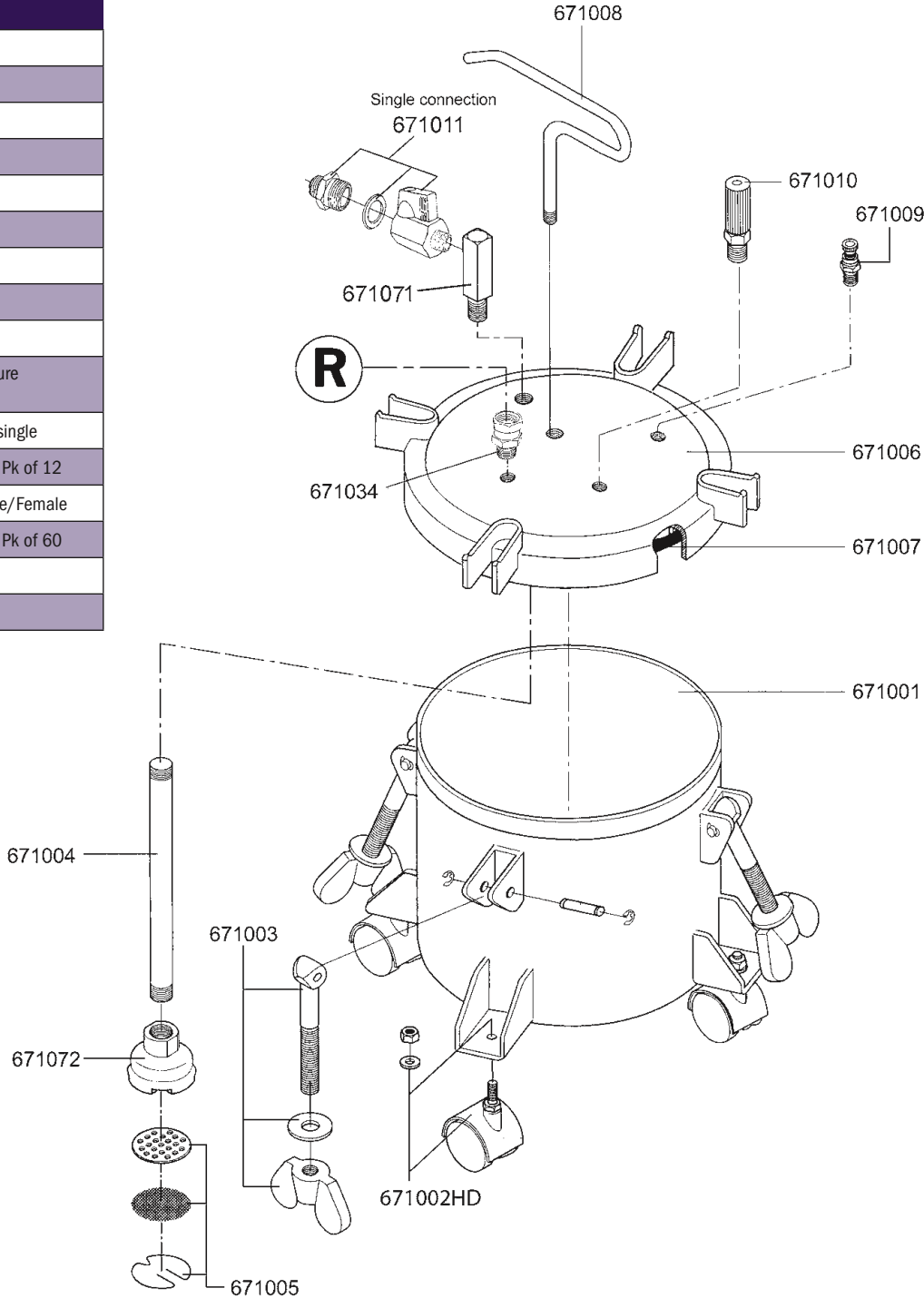

10L disposable liners

671012 Pk of 12
671060 Pk of 60

(R) = Regulator
See page 168

Errors, technical modifications and printing errors reserved

Spare Parts Dan-Am 10 Liter Pressure Tank Lid

Order No./Desc.	
671007	Lid gasket
671009	Pressure relief valve
671010	Secondary over pressure release valve
671011	Fluid valve assembly
671019	Manual agitator shaft
671020	Manual crank base
671021	Manual crank handle assm.
671022	Parts guard assembly
671023	Pneumatic agitator shaft
371024	Motor base assembly
671025	Connecting bushing assm.
671026	Air motor
671033	Agitator air line assm.
671034	Swivel connector, male/female
671035	Tank lid
671071	Fluid outlet
671073	Manual agitator propeller w/bolt
671074	Pneumatic agitator propeller w/bolt
671075	Agitator base nut
671076	Manual agitator shaft lock collar w/bolt
671077	Agitator base gaskets
671078	Pneumatic agitator shaft lock collar assembly
671079	O-ring, Manual agitator base, pack of 2
671080	O-ring, Pneumatic agitator base, pack of 2

Pneumatic Air Agitator Version

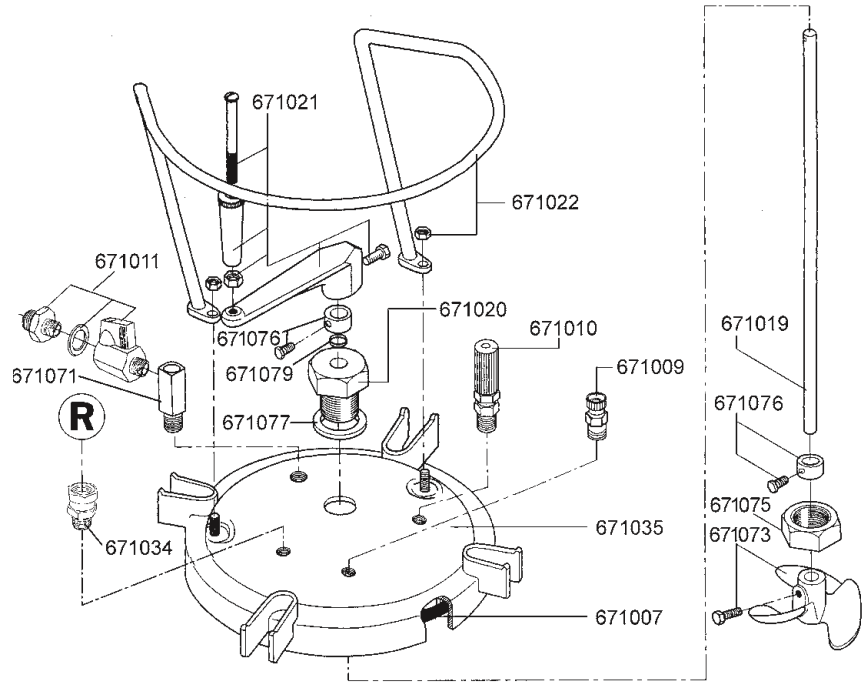

Manual Crank Agitator Version

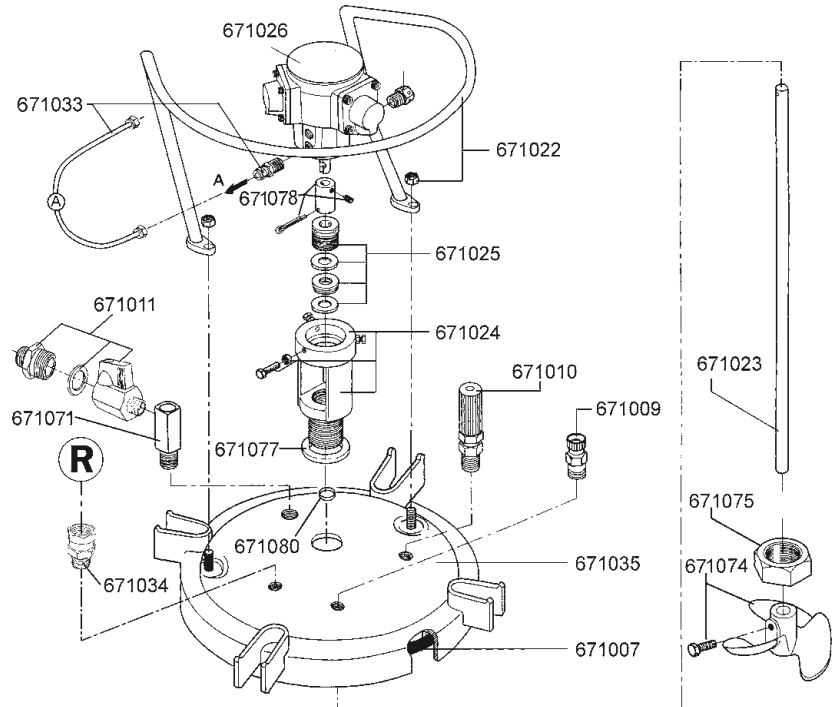

R = Regulator
See page 168

Errors, technical modifications and printing errors reserved

Spare Parts Dan-Am 20 & 40 Liter Pressure Tank Lid

Order No./Desc.	
671002HD	Wheel assembly
671003	Swing bolt assembly
671008	Handle
671009	Pressure relief valve
671010	Secondary over-pressure release valve
671011	Fluid valve assembly
671020	Manual crank base
671021	Manual crank handle
671024	Motor base assemble
671025	Connecting bushing assm.
671026	Air motor
671030	Plug, male
671033	Barb fitting
671034	Swivel connector, male/female
671035	Agitator air line
671036	Muffler
671075	Agitator base nut
671076	Manual agitator shaft lock
671077	Agitator base gasket
671078	Pneumatic agitator shaft
671079	O ring, Manual agitator base, (pk of 2)
671080	O ring, Air agitator base, (pk of 2)
672001	Pressure tank, 20-Liter
672002	Fluid tube, 20L
672003	Fluid sieve kit, 20L
672005	Tank lid
672006	Lid gasket
672008	Cap screw
672009	O Ring
672010	Manual agitator shaft, 20-Liter
672011	Parts guard assembly
672012	Disposable liner, 20L Pk of 12
672013	Pneumatic agitator shaft
672024	Disposable liner, 20L Pk of 60
672071	Fluid outlet
672072	Fluid sieve housing
672073	Hand agitator paddle, w/bolt
672074	Pneumatic agitator propeller
674001	Pressure tank, 40-Liter
674002	Fluid tube, 40L
674004	Manual agitator shaft, 40-Liter
674005	Pneumatic agitator shaft, 40L

20 Liter Manual Crank Agitators (20L only)

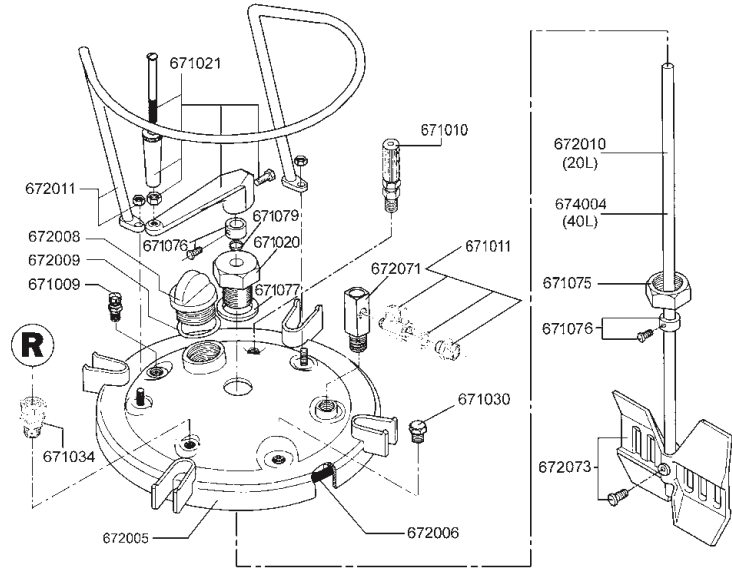

Pneumatic Air Agitator 20L or 40L

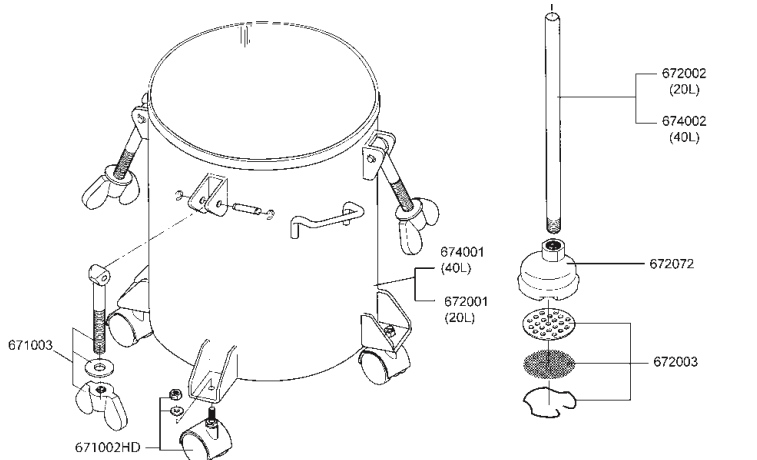
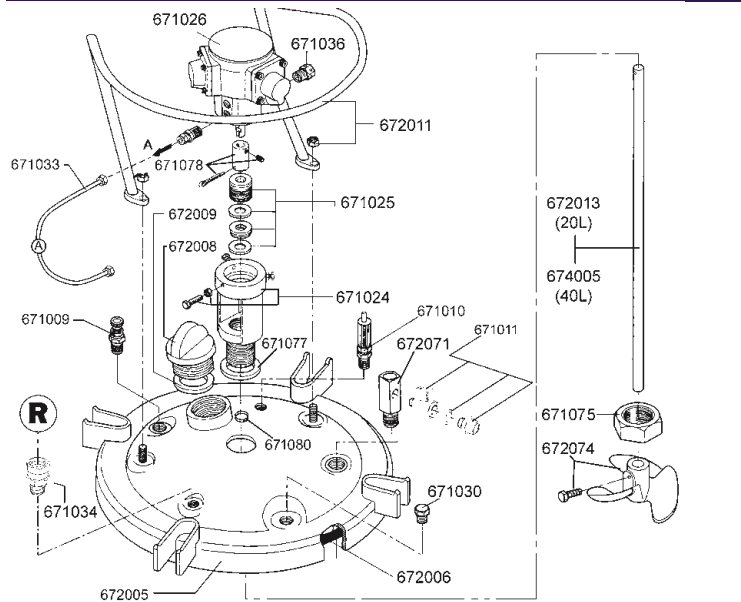

R = Regulator, see page 168

Errors, technical modifications and printing errors reserved

Parts Pressure tank regulators 675640 & 675642

New body style - April 2013



675640 Single regulator for Std and manual stir tanks, 10, 20, & 40L

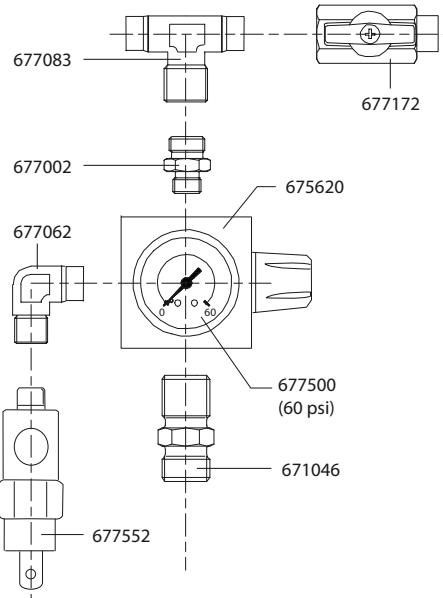

Order No./Desc.

671046	Check valve
675620	Regulator body, 1/4"
677002	Male hex nipple, 1/4"
677062	Street elbow, 1/8"
677063	Street elbow, 1/4"
677083	Tee fitting, 1/4"
677172	Mini ball valve, 1/4"
677500	Gauge, 1-1/2", 60 PSI
677502	Gauge, 1-1/2", 100 PSI
677552	Over pressure valve, 60psi

675642 Dual regulator for std and manual stir tank

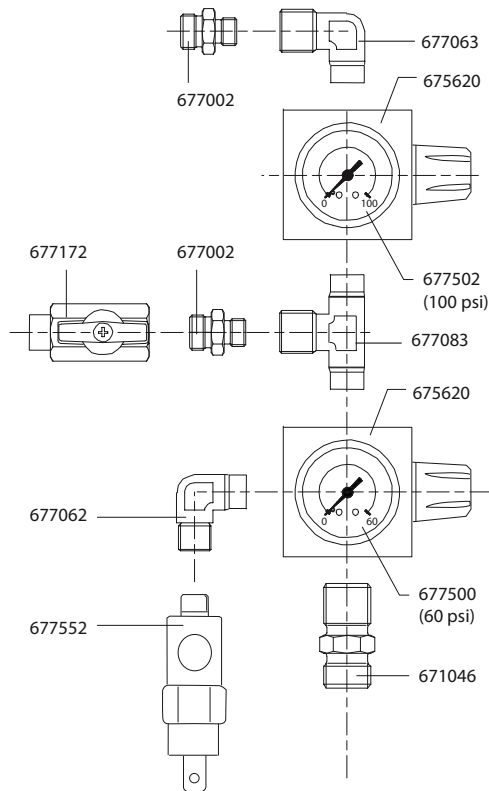

Errors, technical modifications and printing errors reserved

Parts Pressure tank regulators 675644 & 675646

New body style - April 2013

675644 Single regulator for Air Agitated tanks, 10, 20, & 40L

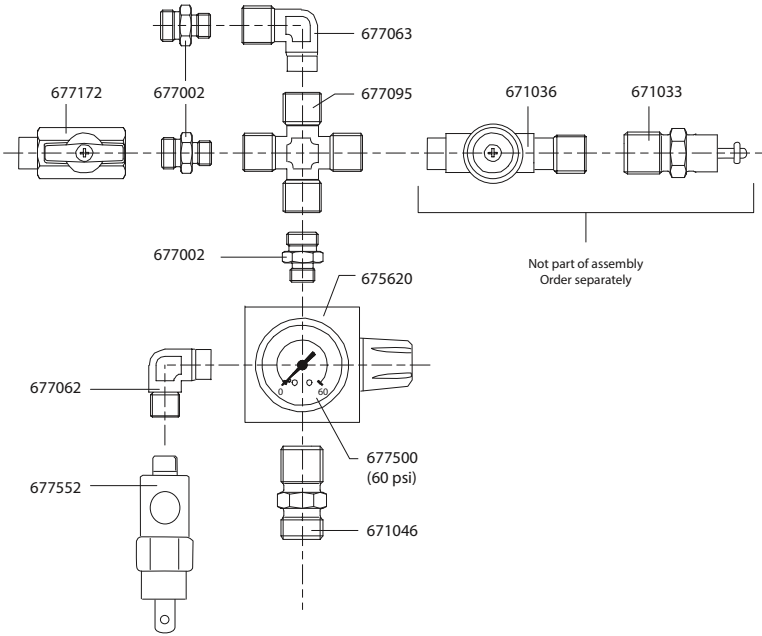

Order No./Desc.	
671033	Agitator airline assembly (includes hose and fasteners)
671036	Agitator shut off valve
671046	Check valve
675620	Regulator body, 1/4"
677002	Hex nipple, 1/4"
677062	Street elbow, 1/8"
677063	Street elbow, 1/4"
677095	Female cross
677172	Mini ball valve, 1/4"
677500	Gauge, 60 PSI, 1-1/2"
677502	Gauge, 100 PSI, 1-1/2"
677552	Over pressure valve, 60psi

675646 Dual regulator for Air Agitated tanks

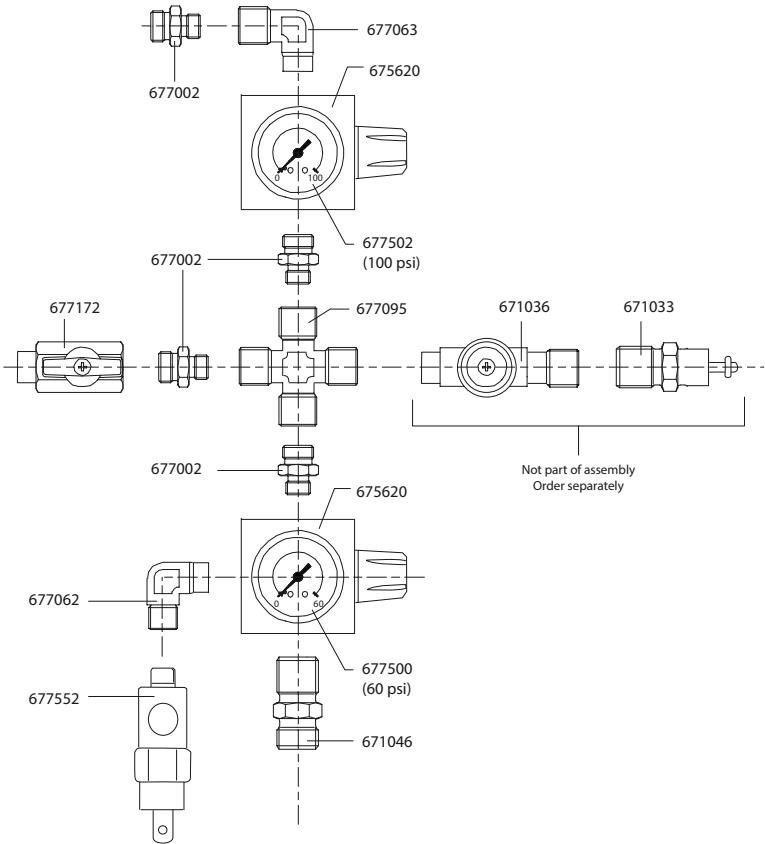

Errors, technical modifications and printing errors reserved

Piranha 338 SS 1:1 Pump

Piranha 338 SS 1:1 Spray System

The Dan-Am Double Diaphragm Pump is a stainless steel unit that delivers consistent fluid delivery with the robust durability of stainless steel.

The unit offers functionality with numerous coatings from low viscosity waterborne to high viscosity urethanes and epoxies. Regardless of your coating selection, the Dan-Am Double Diaphragm is ready to work for you.

The Dan-Am Double Diaphragm Pump is at home in the fleet, manufacturing, cabinet, aviation and marine environment where dependability is a must.

The Dan-Am Double Diaphragm Pump is a user friendly, easy to maintain pump that can be a direct replacement for the conventional pressure pot.



Technical Data

Pressure ratio: 1:1	Material volume stream: 160 stroke: 338 oz/min.
Volumetric delivery / double stroke: 2.11 oz	(approx. double strokes) 1.2 cfm (free flow)
Maximum material pressure: 70 psi	Max. air inlet pressure: 100 psi / Min. air inlet pressure: 15 psi
Maximum stroke frequency: 160 dble stroke (short run)/min	Max. operating temperature: 65° C / Min. operating temperature: 4° C
Maximum dbl stroke frequency: 120 dbl stroke (permanent run)/min	Double diaphragm pump weight: Pump only: 14 lbs, Pump with regulators: 19 lbs

Piranha dual diaphragm pump

685200	Wall mounted, DA 338 stainless steel 1:1 pump	Example for ordering 2nd gun connections; Use single gun connection no. and also order Dual gun delivery No. 685220. Mobile Cart version with 2nd gun connection: Order No. 685400 and Order No. 685220
685300	Stand mount DA 338 stainless steel 1:1 pump	
685400	Mobile cart unit, DA 338 stainless steel 1:1 pump	
685700	DA 338 stainless steel 1:1 pump only	

Piranha dual diaphragm pump accessories

11007	Wall mount unit for high performance pumps
17483	Mobile cart unit for high performance pumps
83840	Stand unit for high performance pumps
685220	Dual gun connection
685743	Sieve unit for suction globe, mesh size 16 (standard)

Dual Hoses

675206	6' Dual hose	
675215	15' Dual hose	
675225	25' Dual hose	
675250	50' Dual hose	

Additional options and set ups are available. Please inquire for customized spray systems to accommodate your needs.

Piranha Pump Spare Parts

Order No./Desc./Qty

685700	Pump Only	1
685701	Bolt M6 - 1.25 x 16	4
685702	Top plate - air motor	1
685703	Bottom plate - air motor	1
685704	Gasket air motor top	1
685705	Gasket air motor bottom	1
685706	Air motor plunger	1
685707	Bolt M6 - 1.25 x 32	2
685708	Gasket air motor to pump	1
685709	Air motor directional valve body	1
685710	Piston w/O-rings - air motor	1
685711	Pump body	1
685712	Silencer	1
685713	Sealing ring, white drive shaft	2
685714	Sq. cut O-ring, black, drive shaft	2
685715	Drive shaft	1
685716	O-Ring	2
685717	O-Ring	2
685718	Bushing	2
685719	Snap Ring	2
685720	Backer plate	2
685721	O-Ring	4
685722	Diaphragm	2
685723	Backer plate	2
685724	SS nut M8 - 1.25	2
685725	SS Cover Plate	2
685726	SS Material outlet manifold	1
685727	SS Material inlet manifold	1
685728	Bolt, M8 - 1.25 x 45	8
685729	Washer, outlet manifold	4
685730	SS plug 3/8	6
685731	Nylon O-ring	8
685733	Ball guide	4
685734	SS check ball	4
685735	Check ball retaining seat	4
685736	Bolt w/nut M8 - 1.25 x 25	12
Pickup Pieces		
685740	SS Adapter 3/8 x 1/2	
685741	SS Coupling 1/2	
685742	SS Pipe 1/2 x 24	
685743	SS Rock catcher 1/2	
685745	SS Pickup. assembly Includes: 685741, 685742, 685743)	
685746	Pump mounting foot	
685747	Mounting plate	
685748	Mounting plate bolt set	

Repair Kits - Piranha Pump

Part no./Descr.

685750	Air Motor Repair Kit Includes: 685704 (1), 685705 (1), 685708 (1), 685710 (1)
685755	Drive Shaft Seal Kit Includes: 685713 (2), 685714 (2), 685716 (2), 685717 (2), 685721 (4)
685760	Drive Shaft Repair Kit includes: Seal Kit #685755 & Driveshaft #685715
685765	Ball Check Valve Repair Kit Includes: 685731 (8), 685733 (4), 685734 (4), 685735 (4)

685770 Piranha 338 Pump

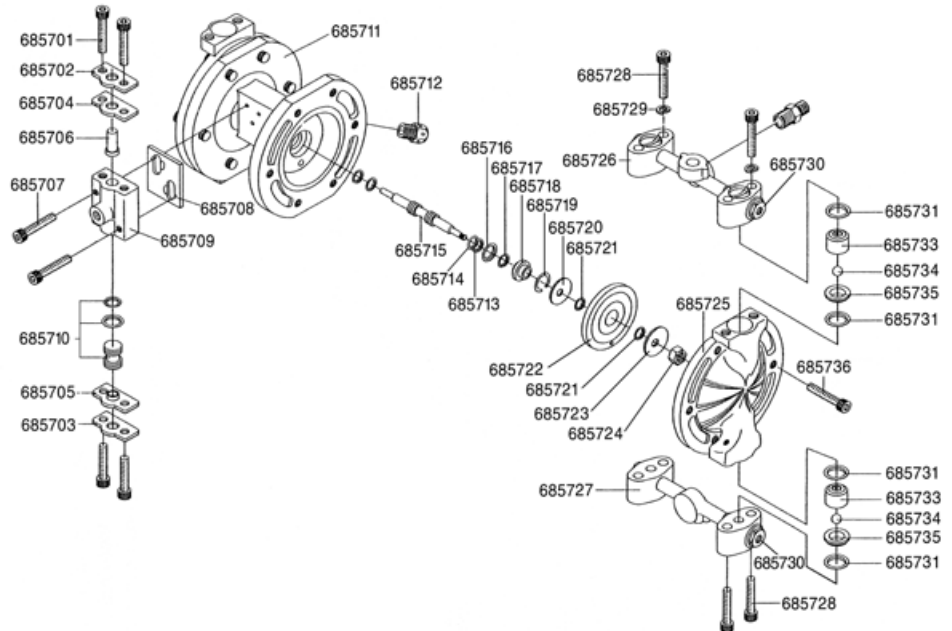

Order No./Desc.

675620	Regulator Body
677002	1/4" Hex Nipple
677039	1/8" Plug
677063	1/4" Street Elbow
677083	1/4" Tee Fitting
677504	1-1/2" Gauge 100 PSI

685770 Dual Regulator

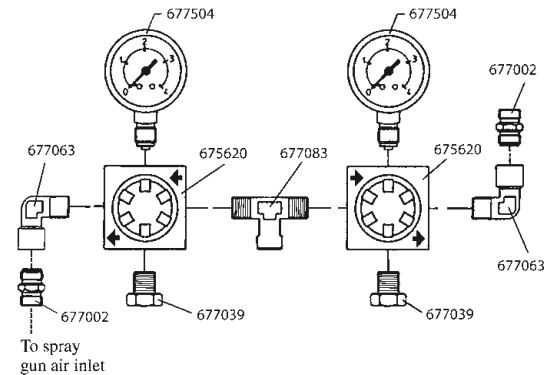

Order No./Desc.

685871	Cap Fluid Regulator
685872	Housing Base Fluid Regulator
685873	Guide Plate
685874	Spring
685875	Diaphragm Assembly
685876	Allen Bolt
685877	Fluid Inlet Check Ball & Seat Assm.
685878	1/4 90° Street Elbow SS
685879	1/4 BSP x 1/4 NPT Adapter SS
685880	1/4 NPT Ball Valve SS
685881	1/4 NPT x 3/8 BSP Adapter SS
685882	Fluid Valve Assembly SS
685883	Gauge - Fluid Regulator
685884	Tube - Fluid Regulator
685885	90° Adapter - Fluid Regulator
685886	Adjustment T - Handle
685887	Nut - Regulator Adjustment
685888	Nut - Fluid Inlet
685889	Fitting - Fluid Inlet
685890	Needle rod

685870 Fluid Regulator

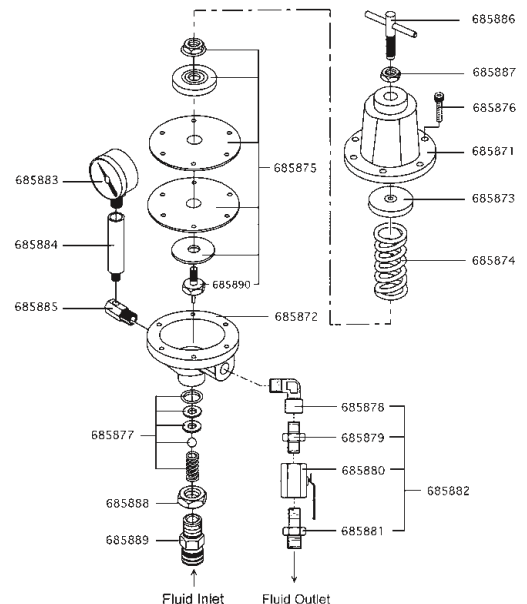

Errors, technical modifications and printing errors reserved

Dan-Am 7232 high pressure pump

Dan-Am 7232

The Dan-Am air-assisted airless piston pump allows the applicator to coat large surfaces rapidly regardless of materials used. That makes the Dan-Am air-assisted airless piston pump suitable for the marine, aviation and miscellaneous motor manufacturing industry.

The Dan-Am air-assisted airless pump system provides low overspray and features stainless steel construction making it suitable for waterborne material.

Trouble free handling, long service and cleaning simplicity is what characterizes the Dan-Am Air Assisted Airless system.

Dan-Am 7232

0641371 Dan-Am Air Assist high pressure pump stainless steel version, w/ cart, High-pressure filter, single gun connection, and grounding wire

Technical Data

Model	7232
Max. free-flow output in liters/min (gal./min)	11 (2.9)
Pressure ratio	32:1
Output per cycle in ccm (fl.oz.)	72 (2.5)
Max. inlet air pressure in bar (psi)	8 (116)
Max. material outlet pressure in bar (psi)	256 (3731)
Approx. air consumption in liter/min. (cu.ft./min)*	311 (11)

*40 cycles per minute at 6 bar (87 psi) inlet pressure

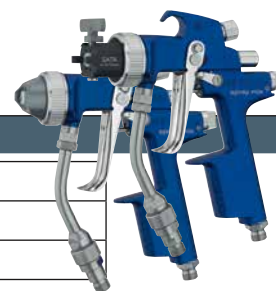

SATAjet 3000 K spray mix (page 16)

Technical Data	Max. operating pressure atomization air: 10.0 bar / 145 psi
	Max. operating pressure material: 250.0 bar / 3,625 psi
	Weight incl. material filter: 650 g / 23 oz.

Spray mix gun



120006	SATAjet 3000 K spray with paint tube, strainer 100 mesh, and nozzle set (specify material nozzle size)
--------	--

Spray mix gun w/ Reversing switch

120014	SATAjet 3000 K spray with paint tube, strainer 100 mesh, and reversing nozzle (specify reversing nozzle size)
120279	Reversing switch kit for SATAjet 3000 K spray mix w/out reversing nozzle

Using a reversing nozzle requires a "one time" purchase of the reversing switch. Part Number 120279

Accessories Dan-Am 7232 high pressure pump

Accessories		
0627434	5 gal. flexible suction tube, stainless steel	
0643901	55 gal. flexible suction tube, stainless steel	
0411329	Stainless steel sieve, flex suction hose M20 (standard)	
0411337	M30	
0411345	M50	
0411353	M70	
0648247	Inlet filter/regulator, w/oiler	
675660	Spray gun regulator, standard single spray gun	
675662	Spray gun regulator for 2nd gun option	
0643930	High pressure filter	
0162787	Filter sieve, 50 msh for high pressure filter #0643930	
0162779	Filter sieve, 70 msh for high pressure filter #0643930	
640225	25 ft dual HP hoses (rated 5000 psi)	
640250	50 ft dual HP hoses (rated 5000 psi)	
0632579	Pneumatic oil for automatic oiler	
0163333	Throat seal lube for material pump	
0474487	Ground wire	

Parts Dan-Am 7232 high pressure air motor

POS	PART NO.	QTY	CODE	DESCRIPTION
1.	0475297	3		dome nut
2.	0460214	3		washer
3.	0641317	1		cover
4.	0641550	3		threaded bolt assembly consisting of pos. 4.1-4.2
4.1	0460192	6		nut
4.2	0641320	3		threaded bolt
5.	0641314	1		safety plate
6.	0474932	1		disc
7.	0641318	1		control cylinder
8.	0310182	4	W, S, R	o-ring
9.	0641151	1		control housing assembly
10.	0460192	2		nut
11.	0641327	1	W, R	control piston assembly
12.	0641319	1		control axle
13.	0475076	1		alignment, insert
14.	0475041	1	W, R	dampening spacer
15.	0494054	1		disc
16.	0480258	1	W, R	carrier assembly
17.	0494054	1		disc
18.	0475041	1	W, R	dampening spacer
19.	0493961	1		retaining ring
20.	0493953	1		disc
21.	0460184	2		nut
22.	0460362	2		threaded pin
23.	0641324	6	W, S, R	o-ring
24.	0475297	4		dome nut
25.	0460214	4		washer
(26.)	0611891	1		safety valve
27.	0641325	1		upper part cpl.
28.	0641331	1		air muffler assembly
29.	0460214	2		washer
30.	0470325	2	W	toggle
31.	0473081	2	W	toggle bearing
32.	0411876	2	W	spring
33.	0475122	2		bearing bush
34.	0641486	4		threaded bolt
35.	0482471	1	W, S, R	bush assembly
(36.)	0489026	1		filler neck assembly
37.	0460214	4		washer
38.	0475297	4		dome nut
39.	0475114	1	W, S, R	seal
40.	0461334	1	R	retaining ring
41.	0311391	1	W, S, R	o-ring
42.	0475149	1		piston plate
43.	0475157	1	W, S, R	guide ring
44.	0477281	1	W, S, R	o-ring
45.	0475165	1	W, R	disc
46.	0641485	1	W, R	guide axle assembly
47.	0641487	1	W	motor axle
48.	0311405	1	W, S, R	o-ring
49.	0641488	1	W	cylinder
50.	0311405	1	W, S, R	o-ring
51.	0631431	2	W, S, R	o-ring
52.	0639014	2		air inlet pipe
53.	0473367	1	R	retaining ring
54.	0631431	2	W, S, R	o-ring
(55.)	0644436	1		elbow
56.	0641326	1		bottom assembly
	0641491		R	Seal kit
	0641490			Repair kit

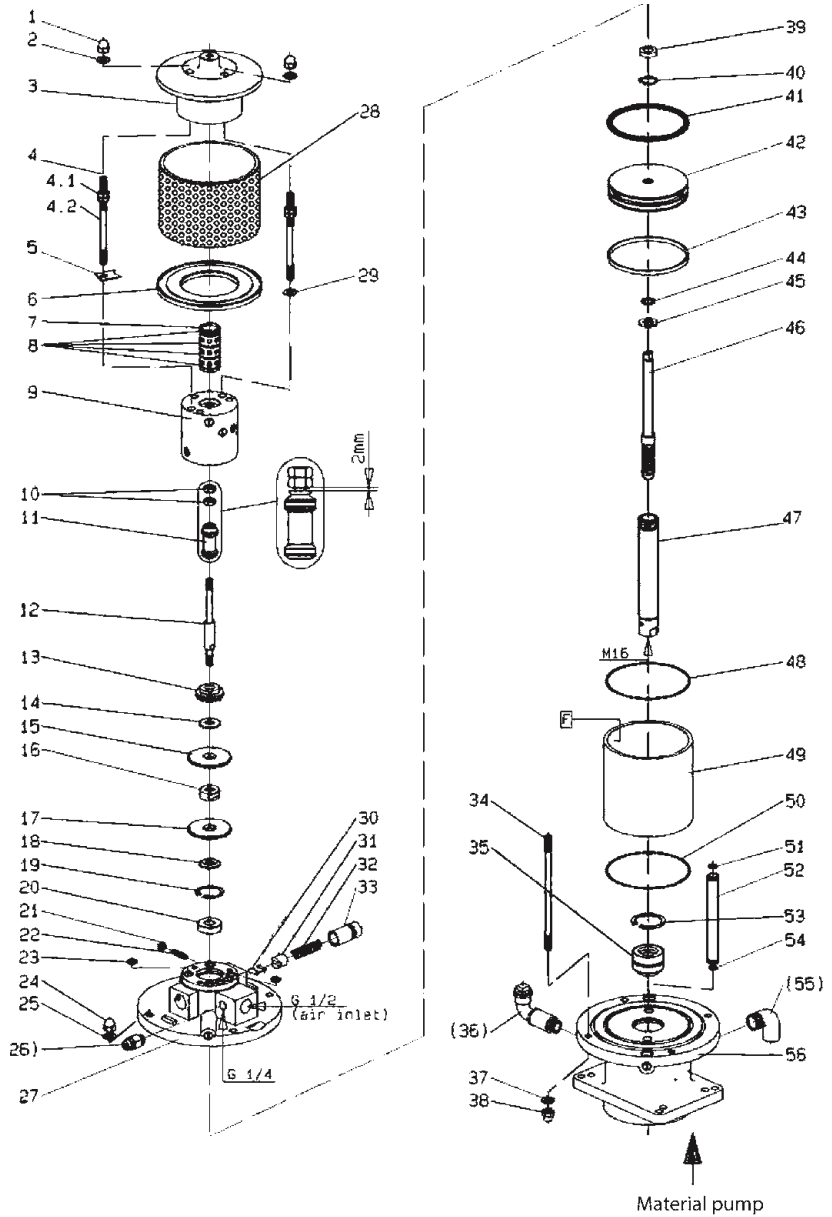

W = Wear part
 S = Included in Seal kit
 R = Included in Repair kit
 Pos. No. marked with () are not part of assembly shown

Parts Dan-Am 7232 high pressure material pump

POS	PART NO.	QTY	CODE	DESCRIPTION
(1.)	0641493	1	S,R	o-ring
2.	0646931	1		high pressure head
(3.)	0163686	1		drain valve assembly consisting of pos. (3.1)-(3.3)
(3.1)	0210714	1		draining screw
(3.2)	0310239	1	S, R	o-ring
(3.3)	0221759	1		valve housing
4.	0641430	1		connecting ring
(5.)	0477184	4		screw
6.	0641443	1		saddle ring
7.	0641449	1	W,R	packing ring set mixed consisting of pos. (7.1) - (7.4)
7.1	0630062	1	W,R	packing ring teflon
7.2	0631811	1	W,R	packing ring leather
7.3	0630062	1	W,R	packing ring teflon
7.4	0630062	1	W,R	packing ring teflon
8.	0641446	1		counter ring
9.	0465852	1	S, R	gasket
10.	0641445	1		spring
(11.)	0603619	1		gasket
(12.)	0063835	1	W	non-return valve assembly
13.	0646934	1		spring housing
14.	0641445	1		spring
15.	0465852	1	S, R	gasket
16.	0640052	1		sight glass
(17.)	460745	1	R	tension
18.	0647458	1	W	dual piston cpl. consisting of pos. 18.1-18.5
18.1	0647456	1	W	dual piston
18.2	0648573	1		ball guide
18.3	0647394	1	W	cylindrical pin
18.4	0410195	1	W,R	ball
18.5	0618586	1	W	valve screw cpl.
19.	0630103	1		counter ring
20.	0641450	1	W,R	packing ring set mixed consisting of pos. 20.1-20.4
20.1	0627978	1	W,R	packing ring teflon
20.2	0627978	1	W,R	packing ring teflon
20.3	0310425	1	W,R	packing ring leather
20.4	0627978	1	W,R	packing ring teflon
21.	0641444	1		saddle ring
22.	0641452	1		pressure cylinder
23.	0218162	1	S, R	gasket
24.	0641146	1		retaining ring
25.	0641069	1		sleeve
26.	0641129	1	W, R	cylindrical pin
27.	0410225	1	W,R	ball
28.	0605743	1		ball guide
29.	0646635	1	W	valve housing cpl.
30.	0218057	1	S, R	gasket
	0646928		R	seal kit
	0646973			repair kit

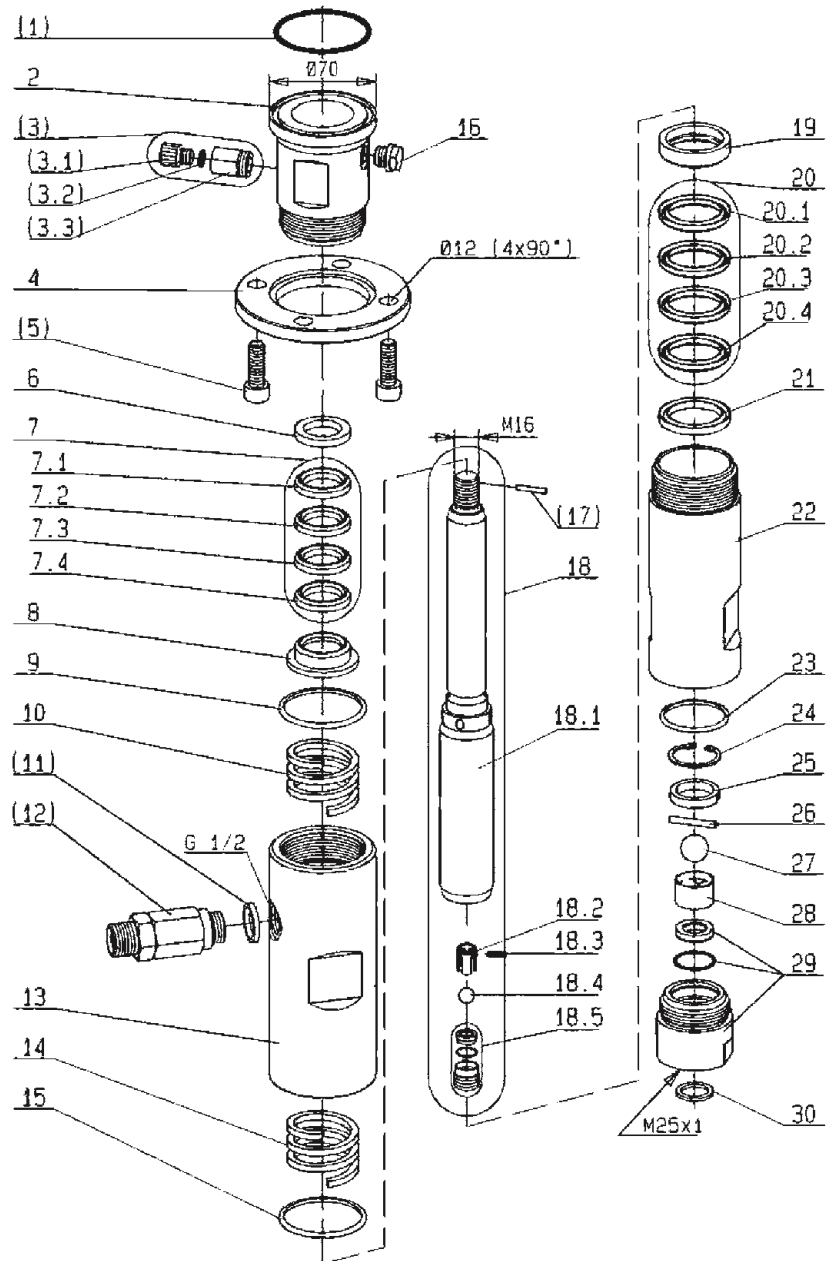

W = Wear part
 S = Included in Seal kit
 R = Included in Repair kit
 Pos. No. marked with () are not part of assembly shown

Dan-Am 2710 medium & 2733 high pressure pump

The Dan-Am Spray-Mix System benefits at a glance:

- High material savings
- The finest atomization generates first class finishes
- Low operating costs due to minimal air consumption
- Soft, controllable spray pattern
- Low pump wear due to low material pressure
- Environmentally friendly due to minimal overspray

Dan-Am 2710 & 2733 pressure pumps

- 2 Pressure ratios choices: Medium 10:1 or High 33:1
- 27 ccm Material delivery per double stroke
- Perfect finishing system for high quality, even finishes
- Ideal for trade and industry:
Cabinet shops, Furniture industry, Paint & Finish shops, Machine construction
- Highly portable for flexible use in almost any location.
- Dual filter system prevents downtime.
- Spring loaded, self-adjusting packings reduce wear and tear.
- Heavy duty housing and a new seal system further improve safety.
- Quick and simple maintenance

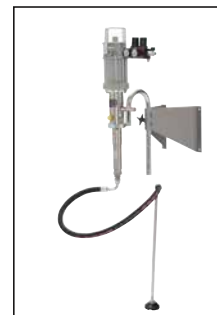

Technical Details

Model	2710	2733
Max. free-flow output in liters/min (gal./min)	4.2 (1.10)	4.2 (1.10)
Pressure ratio	10:01	33:01:00
Output per cycle in ccm (fl.oz.)	27 (0.9)	27 (0.9)
Max. inlet air pressure in bar (psi)	8 (116)	8 (116)
Max. material outlet pressure in bar (psi)	80 (1160)	264 (3830)
Approx. air consumption in liter/min. (cu.ft./min)*	81.6 (2.88)	235 (8.3)
*40 cycles per minute at 6 bar (87 psi) inlet pressure		

Air Assist Pump Systems order form page 180

Hoses pg 161

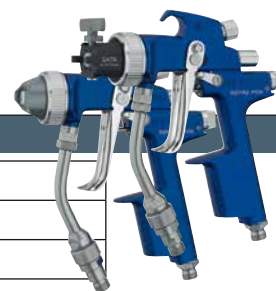

SATAjet 3000 K spray mix (page 16)

Technical Data

- Max. operating pressure atomization air: 10.0 bar / 145 psi
- Max. operating pressure material: 250.0 bar / 3,625 psi
- Weight incl. material filter: 650 g / 23 oz.

Spray mix gun

120006 SATAjet 3000 K spray with paint tube, strainer 100 mesh, and nozzle set (specify material nozzle size)

Spray mix gun w/ Reversing switch

120014 SATAjet 3000 K spray with paint tube, strainer 100 mesh, and reversing nozzle (specify reversing nozzle size)

120279 Reversing switch kit for SATAjet 3000 K spray mix w/out reversing nozzle

Using a reversing nozzle requires a "one time" purchase of the reversing switch. Part Number 120279

See page 16 for nozzle sizes

Dan-Am 2710 & 2733 accessories

10:1 piston pump accessories

0644299	2710, 10:1 pump only	
0643694	2733, 33:1, pump only	
11007	Wall mount unit for high performance pumps	
17483	Cart unit for high performance pumps	
0634509	High pressure filter for high performance pumps	
0163023	M50 (std), orange, HP filter replacement insert	
0160059	M100, black, HP filter replacement insert	
0160628	M150, red, HP filter replacement insert	
0160636	M200, white, HP filter replacement insert	
0163333	Rinsing fluid (Oil), for high performance pumps, throat seal tube	
83840	Stand unit for high performance pumps	
97279	Spray mix dual regulator, single gun connection	
97287	Spray mix triple regulator, dual gun connection	
0627401	5.0 gal / 18.9 l flex tube	
Inquire	55.0 gal / 208.1 l flex tube	
640225	25 ft dual high pressure hose	
640250	50 ft dual high pressure hose	
0639123	2 gun material connection	
0643913	Std. inlet suction tube	
0479101	Std. inlet tube sieve	

Additional options and set ups are available. Please inquire for customized spray systems to accommodate your needs.

Parts Dan-Am 2710 & 2733 air motor

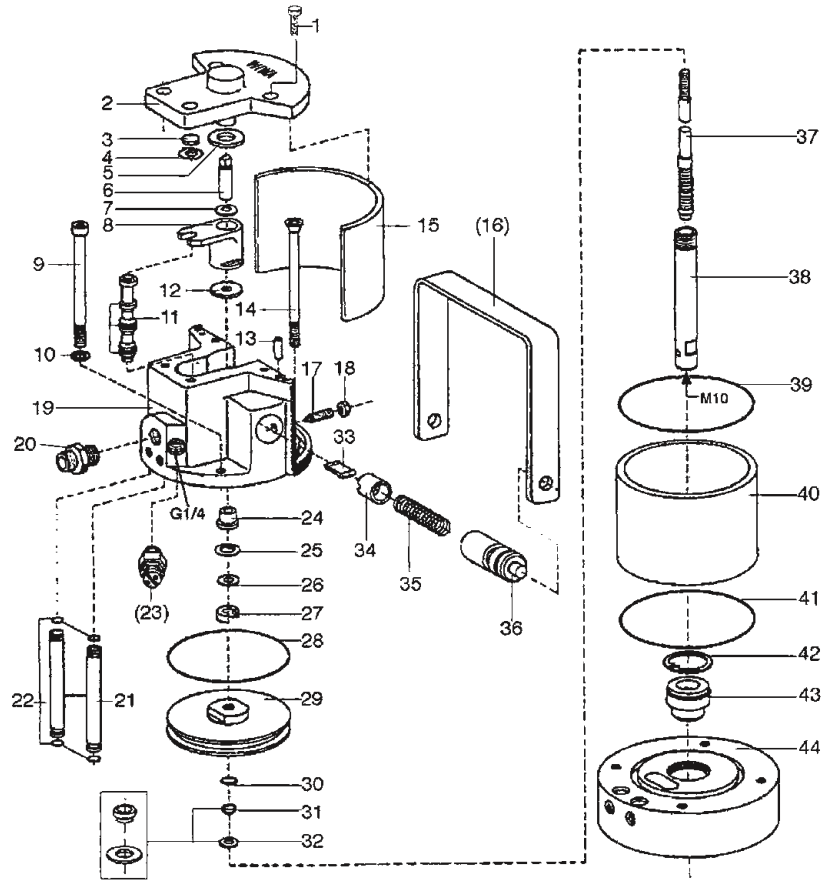

Part No. in Red 33:1 only

Part No. in Green: 10:1 only

Part No. in Black: common

POS	PART NO.	QTY	CODE	DESCRIPTION
1	0460508	4		screw
	0473820	1		cover cpl., pos. 2-4
2	0470309	1		cover
	0470236	1		bush (not illustrated)
3	0470252	1	W, R	dampening spacer
4	0473162	1	R	jagged ring
5	0470279	1	W, R	dampening spacer
6	0470201	1		bolt
7	0470147	1		disc
8	0473111	1	W	carrier cpl.
9	0638922	2		screw
10	0460591	2		washer
11	0473170	1	W, R	control piston cpl.
12	0470287	1	W, R	dampening spacer
13	0473189	2		cylindrical pin
14	0638920	2		screw
15	0470368	1		dampening plate
16	0473200	1		handle
17	0473812	2		threaded pin
18	0460184	2		nut
19	0621498	1		upper part cpl.
20	671034	1		male adaptor
21	0638916	2		air inlet pipe
22	0470392	4	S, R	o-ring
23	0611891	1		safety valve
24	0470155	1		flange sleeve
25	0470384	1	R	retaining ring
26	0476137	1		disc
27	0310204	1	W, S, R	lip seal

POS	PART NO.	QTY	CODE	DESCRIPTION
28	0482609	1	W, S, R	o-ring
28	0478652	1	W, S, R	o-ring
29	0610666	1		piston plate
29	0611271	1		piston plate
30	0310174	1	W, S, R	o-ring
31	0610631	1	R	guide ring
32	0610658	1	R	disc
33	0470325	2	W	toggle
34	0473081	2	W	toggle bearing
35	0617709	2	W	spring
35	0652343	2	W	spring
36	0470171	2		bearing bush
37	0638918	1	W, R	guide axle cpl.
38	0644228	1	W	motor axle
39	0482617	1	S, R	o-ring
39	0310514	1	S, R	o-ring
40	0638919	1	W	cylinder
40	0644230	1	W	cylinder
41	0482617	1	S, R	o-ring
41	0310514	1	R	o-ring
42	0473251	1	R	retaining ring
43	0482625	1	W, S, R	guide bush cpl.
44	0622079	1		bottom cpl.
	0641232		R	Seal kit, 33:1
	0641230		R	Seal kit, 10:1
	0641237			Repair kit, 33:1
	0649499			Repair kit, 10:1

W = Wear part

S = Included in Seal kit

R = Included in Repair kit

Pos. No. marked with () are not part of assembly shown

Parts Dan-Am 2710 & 2733 material pump

POS	PART NO.	QTY	CODE	DESCRIPTION
(1.)	0642643	1		filler neck assembly consisting of pos.(1.1)-(1.4)
(1.1)	0498351	1		extension
(1.2)	0642586	1		T-piece
(1.3)	0642587	2		plug (includes pos.(1.4))
(1.4)	0632184	2	S, R	o-ring
2.	0644213	1		saddle ring
3.	0644380	1	W, R	packing ring set mixed consisting of pos. 3.1-3.2
3.1	0644189	3	W, R	packing ring teflon
3.2	0644182	1	W, R	packing ring leather
4.	0644212	1		counter ring
5.	0644181	2		spring
6.	0644184	1	S, R	o-ring
7.	0644216	1		counter ring
8.	0644381	1	W, R	packing ring set mixed consisting of pos. 8.1-8.2
8.1	0644214	3	W, R	packing ring teflon
8.2	0644183	1	W, R	packing ring leather
9.	0644215	1		saddle ring
10.	0481394	1	W, R	cylindrical pin
11.	0604615	1		ball guide
12.	0631634	1	S, R	o-ring
13.	0411361	1	W	valve seat
(14.)	0644233	1	R	retainer
(15.)	0311928	1	S, R	o-ring
16.	0473537	1		retaining ring
17.	0471658	1		connecting ring
18.	0644238	1		pump head
(19.)	0060585	1	W	non return valve
(20.)	0611778	1	S,R	seal
21.	0644184	1	S, R	o-ring
22.	0644239	1		spring housing
23.	0650183	1		dual piston cpl. consisting of pos.23.1-23.6
23.1	0644221	1	W	dual piston
23.2	0483664	1	W	ball stop assembly consisting of pos.23.2.1-23.2.2
23.2.1	0460338	1	W	tension pin
23.2.2	0478806	1		spacer sleeve
23.3	0410187	1	W, R	ball
23.4	0644241	1	S, R	o-ring
23.5	0410527	1	W	valve seat
23.6	0219002	1		threaded plug
24.	0644240	1		pressure cylinder
25.	0641336	1	S, R	o-ring
26.	0410217	1	W, R	ball
27.	0644237	1		valve housing
28.	0218057	1	S, R	seal
	0644382		R	seal kit (standard)
	0644383			repair kit (standard)

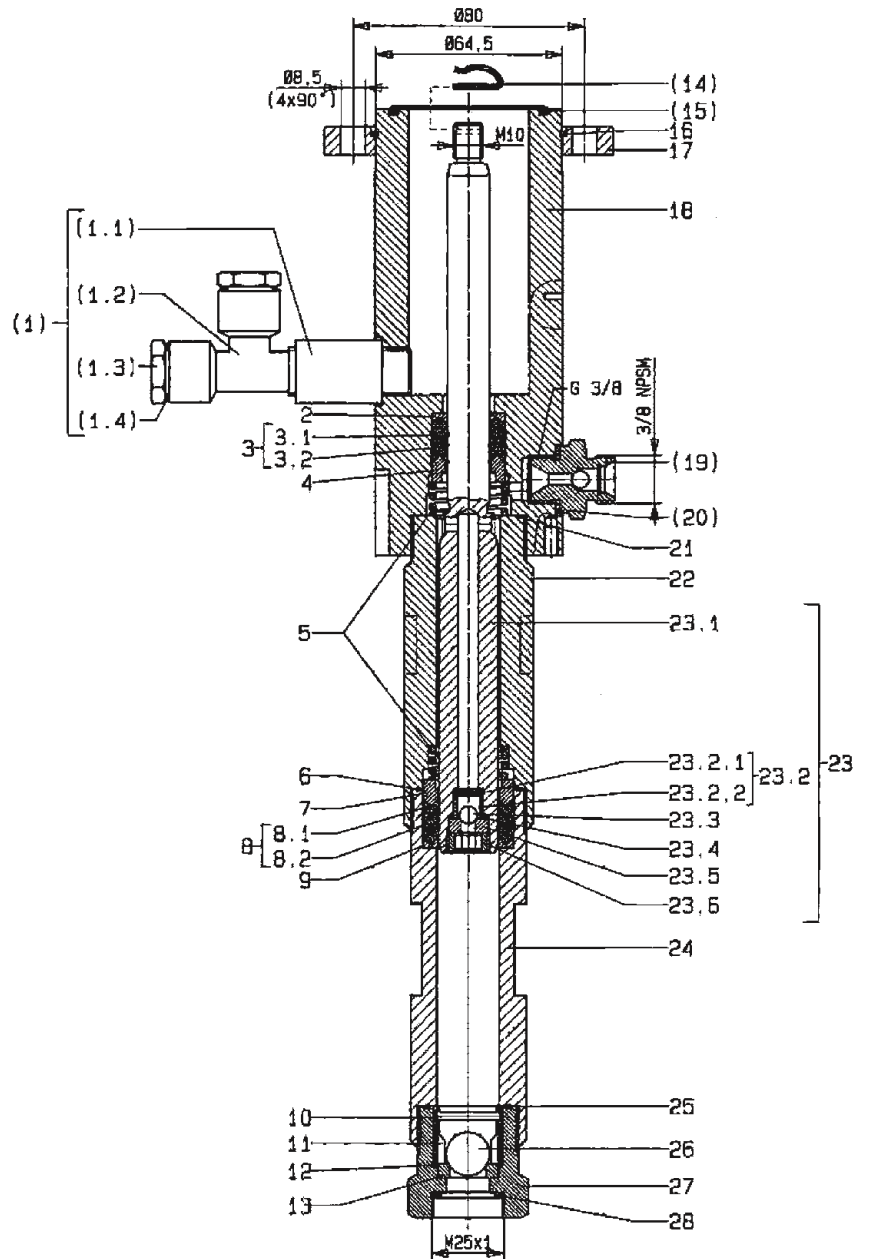

Errors, technical modifications and printing errors reserved

Dan-Am Pump Part Number Order System

DAN-AM AIR ASSIST PUMP SYSTEMS PART NUMBERING SYSTEM

Enter numbers in boxes to calculate our cost.

	<input type="text" value="H"/>	<input type="text"/>	<input type="text"/>	<input type="text"/>	<input type="text"/>	<input type="text"/>
PUMP RATIO	←					
1 10:1 PUMP 2710						
2						
3 33:1 PUMP 2733						
MOUNTING SYSTEM		←				
0 NO MOUNT						
2 WALL						
3 FLOOR STAND						
4 TROLLEY						
HOSE LENGTH			←			
0 NO HOSE						
2 25' DUAL HOSE						
5 50' DUAL HOSE						
GUN SETUP				←		
0 NO GUN						
1 1 GUN						
2 2 GUNS						
HP FILTER					←	
0 WITHOUT FILTER						
1 WITH FILTER						

ALL SYSTEMS BEGIN WITH THE LETTER H
ALL SYSTEMS INCLUDE INLET AIR REGULATORS & STANDARD SUCTION TUBE
SYSTEMS WITH GUNS COME WITH THE SATAJET 3000K SPRAY MIX WITH A 3350 NOZZLE
PLEASE SPECIFY IF YOU WOULD LIKE A DIFFERENT NOZZLE SIZE.

Errors, technical modifications and printing errors reserved

Dan-Am 5 gallon agitator lid

Dan-Am 5 gallon agitator lid

- Complete Stainless Steel Construction – Suitable for Waterborne Coatings
- Durable GAST Air Motor construction
- Complete range of speed variability



640100 Dan-Am 5 gallon agitator lid, pail mount



Spare Parts Dan-Am 5 gallon agitator lid

POS	Part No.	Description
1	640100	Agitator Lid complete
2	640110	Air motor 1UP-NCC-1A w/muffler
3	640111	Impeller, ss, w/shaft
4	640112	Coupler, air motor to impeller (not visible)
5	640113	7/8 inch lock collar
6	640114	1 1/4 inch lock collar
7	640115	Air regulator
8	640117	Thumb screw 1/4 x 1 1/4 inch (ea.)
9	640120	14 ga x 5 ft ground wire



Errors, technical modifications and printing errors reserved

Viscosity Cup Conversion Chart - SATA Din 4

SATA DIN 4	POISE	CENTIPOISE	DUPONT PARLIN 7	DUPONT PARLIN 10	FISHER 1	FISHER 2	FORD CUP 3	FORD CUP 4	KREBS UNITS KU	SAYBOLT UNIVERSAL SSU	ZAHN 1	ZAHN 2	ZAHN 3	ZAHN 4	ZAHN 5	SATA DIN 4
9	0.1	10	27	11	20			5		50	30	16				9
11	0.15	15	30	12	25			8		80	34	17				11
12	0.2	20	32	13	30	15	12	10		100	37	18				12
15	0.25	25	37	14	35	17	15	12		130	41	19				15
17	0.3	30	43	15	39	18	19	15		160	44	20				17
18	0.4	40	50	16	50	21	25	17		210	52	22				18
20	0.5	50	57	17		24	29	19	30	260	60	24				20
22	0.6	60	64	18		29	33	21	33	320	68	27				22
23	0.7	70		20		33	36	23	35	370		30				23
24	0.8	80		22		39	41	26	37	430		34				24
28	0.9	90		23		44	45	29	38	480		37	10			28
30	1.0	100		25		50	50	31	40	530		41	12	10		30
32	1.2	120		30		62	58	36	43	580		49	14	11		32
39	1.4	140		32			66	41	46	690		58	16	13		39
42	1.6	160		37				45	48	790		66	18	14		42
46	1.8	180		41				51	50	900		74	20	16		46
50	2.0	200		45				56	52	1000		82	23	17	10	50
55	2.2	220						61	54	1100			25	18	11	55
59	2.4	240						67	56	1200			20	12	12	59
64	2.6	260						72	58	1280			30	21	13	64
67	2.8	280						76	59	1380			32	22	14	67
70	3.0	300							60	1475			34	24	15	70
74	3.2	320								1530			36	25	16	74
79	3.4	340								1630			39	26	17	79
83	3.6	360							62	1730			41	28	18	83
86	3.8	380								1850			43	29	19	86
89	4.0	400							64	1950			46	30	20	89
94	4.2	420								2050			48	32	21	94
100	4.4	440								2160			50	33	22	100
105	4.6	460							66	2270			52	34	23	105
110	4.8	480							67	2380			54	36	24	110
122	5.0	500							68	2480			57	37	25	122
131	5.5	550							69	2660			63	40	27	131
150	6	600							71	2900			68	44	30	150
172	7	700							74	3375				51	35	172
193	8	800							77	3880				58	40	193
274	9	900							81	4300				64	45	274
	10	1000							85	4600					49	274
	11	1100							88	5200					55	274

General guidelines for gravity guns using a DIN 4 viscosity cup

(use smaller nozzle sizes for pressure fed and larger for siphon feed guns)

General guidelines for nozzle size

- 1.2 for water borne
- 1.3 for basecoat, some clears with low VOC on HVLP
- 1.4 for clearcoat, single stage, surfacer, sealer, epoxy, waterborne, wash and etch primer
- 1.5 for clearcoat, single stage
- 1.6 for primer
- 1.7 for primer, filler
- 1.8 for primer, filler
- 1.9 for filler, high build
- 2.0 for filler, high build
- 2.5 for polyester



SATA Viscosity Cup

Using a viscosity cup will ensure consistent measuring of material viscosity for selecting the right nozzle size. DIN 4 (4).

Extruded Aluminum

Each **Order No. 9852**

Turned Aluminum

Each **Order No. 9845**

How to use a SATA DIN 4 viscosity cup

The DIN (German engineering standard) viscosity cup, part number 9852 is a 100ml container with a 4 orifice. To measure material viscosity, dip the cup in the material, using a stopwatch or second hand on a watch, check how many seconds it takes for the cup to empty. The clearance time is the DIN viscosity expressed in seconds. Determining the viscosity makes nozzle selection easier. Also check paint company application charts for nozzle sizes.

HVLP TEST AIR CAP



The SATA test air cap with dual gauges is a visual means of proving HVLP compliance. By fitting the with this air cap and turning the fan control through its entire range, both center and horn air cap pressure can be verified. When the recommended air inlet pressure is applied to the, the maximum air cap pressure will not be exceeded. All SATA HVLP guns are at least 65% transfer efficient and meet all HVLP legislation.

The dual test gauge is normally used for classroom or demo work. Purchasing the SATA test air cap with dual gauges may be required by local or state ordinance, and is a useful tool to check accurate pressure settings.

SATA HVLP Gun Set-Up is as simple as 1 - 2 - 3

1. Use a minimum 3/8 ID air hose with non-restrictive nipples and couplings.
2. Use the SATA adam2 digital air micrometer, SATA adam 2 dpg (digital pressure gauge), SATA air micrometer with gauge #27771 or the SATA line pressure gauge #43786, for accurate pressure Setting. For DIGITAL Sata guns use built in digital air micrometer.
3. Set the recommended inlet air pressure with the trigger pulled and the built-in air micrometer (control at rear of gun), set to the 12:00 o'clock position. You're ready to shoot after setting fluid and fan control.

SATA HVLP's are internally engineered to do the rest. The Venturi principle (air converter) automatically reduces recommended inlet air pressure to the maximum 10 psi allowed. SATA HVLP nozzle sets are engineered for fine atomization and high performance at low air pressure.

Metric to Decimal Conversion Chart			
0.15mm = .0059	1.0mm = .0394	1.9mm = .0748	
0.2mm = .0078	1.1mm = .0433	2.0mm = .0787	
0.25mm = .0098	1.2mm = .0472	2.1mm = .0827	
0.35mm = .0138	1.3mm = .0512	2.2mm = .0866	
0.5mm = .0197	1.4mm = .0551	2.3mm = .0906	
0.6mm = .0236	1.5mm = .0591	2.4mm = .0945	
0.7mm = .0276	1.6mm = .0630	2.5mm = .0984	
0.8mm = .0315	1.7mm = .0669	3.0mm = .1181	
0.9mm = .0354	1.8mm = .0709	5.0mm = .1969	
Approximately 28.3 l/min = 1 cfm.	Approximately 1 Bar = 14.5 psi	DIN 4 Viscosity Cup Orifice 4mm = .1575	
0.9463 liter = 1 qt	.03 liter = 1 oz.	2.54 cm = 1 inch	1 meter = 39.37 inches
8 oz = 1 cup	16 oz = 1 pint	32 oz = 1 quart	128 oz = 1 gallon

SATA Calculator Available

@ www.satausa.com

Services > Paint Advisor > Calculator

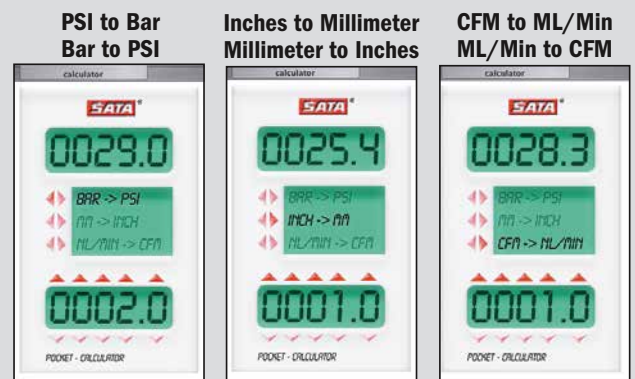

SATA calculator has six conversions.

Errors, technical modifications and printing errors reserved

Dan-Am Brochures,

Brochures and Leaflets

Order No./Desc.	
1	Binder/Catalog/Price List
2	SATA/Dan-Am Catalog
2A	Numerical Catalog Price Guide
6	SATA News
9	SATA Catalog & Brochures
12	Awesome Paint Jobs Brochure
19A	SATAjet 100 B Brochure
21	SATAminijet 3000 Brochure
22	Design Guns Brochure
23	Pressure Fed Guns Brochure
24	Rustproofing Brochure
25	400 Filter System Brochure
26	200 Filter System Brochure
27	SATAminijet 1000 K
29	Satajet 3000 B Brochre
29A	Satajet 4000 B Brochure
31	Air-Star Half Mask Brochure
32	Automatic/ROB Gun Brochure
33	Piston Pump Brochure

Order No./Desc.	
34	A to Z Industrial Equipment Brochure
36	Dan-Am Pressure Tank Brochure
38	Vario-Top Pump Brochure
39	Perfect Finish Results Brochure
40	Commercial *S*A*M*S Brochure
41	H2O Waterborne Brochure
41A	Jet-Dry Stands Brochure
42	Automotive *S*A*M*S Brochure
44A	Hosemate Brochure
45	Dry-Jet System Brochure
46	RPS Cup Brochure
47	Adam 2 Digital Micrometer Brochure
48A	Carbon Monoxide Monitor Brochure
55	EZ Flex Paint Stand
58	DanAm Air Brochure
59	DAA filtration and layout pads, 1 ea.
60	DanAm Air Ag Brochure
158162	Cleaning and Maintenance of Paint Spray Guns



SATA Decals and Posters

Order No./Desc.	
6239	SATA Spray Gun Booklet
99671	SATA logo decal 4 x 1.5
99689	SATA logo decal 12 x 4
99697	SATA logo decal 24 x 8
121046	SATA Authorized Dealer 6.5 x 3



Order No./Desc.	
61	Respirator Health Protection (Deadman poster)
69	Jet 4000 Poster - 23.5 x 33
158162P	Spray Gun Washer & Manual Cleaning Poster - 2 sided, manual and gun washer, 18 x 24
181222	SATAjet 4000 B cutaway, 24 x 34
181412	SATA filter 400 cutaway, 24 x 34

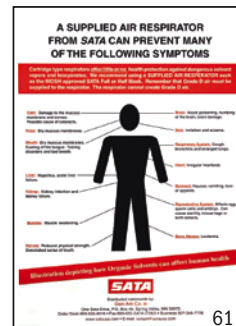
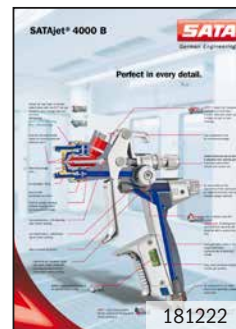

Warranty

SATA WARRANTY

During the twelve (12) month period from the date of original purchase SATA will repair or, at its option, replace the product without charge for parts or labor subject to the following conditions.

The warranty covers the value for production parts or defects in material during the warranty period. The warranty does not include damages caused by improper handling, normal wear and tear, mechanical damages, faulty assembly, improper maintenance, unusual spray materials or chemicals.

Sprayable abrasive materials reduce the lifetime of valves, packings, guns and nozzles. Wear and tear damage caused by this are not covered in this warranty.

Our units should be inspected upon delivery by the consumer. Obvious damage must be reported within 14 days of receipt of the unit to the supplier to avoid loss of the right to claim notice of defects.

SATA holds itself harmless for damages caused during meetings, training sessions or demonstrations.

Should the consumer require immediate repair or replacement before a determination of whether the affected unit is covered by the warranty, the repair or replacement will be made and charged at the current prices. If it is determined that the item is covered by the warranty, a credit will be issued for repair or replacement. Replaced parts become the property of SATA or their distributor.

Notice of defects or other claims do not entitle the consumer to delay or refuse payment. Returned merchandise to SATA must be sent prepaid. All service charges, freight and handling charges are to be paid by the consumer.

The charges made will be in accordance with the current existing pricing.

Suretyships may not prolong the warranty period. This warranty terminates upon unauthorized interference.

We believe you will agree that the painter is ultimately responsible for the maintenance and mechanical condition of their spray gun.

Warranty work does not include the following:

1. Internal or external cleaning of the spray gun or any part thereof. On warranty claims, your spray gun must be received in clean condition, ready for testing when received in our repair department. Otherwise a \$30.00 minimum charge will be incurred.
2. Damage to any nozzle component caused by vise-grips, pliers, nails, wire or any other foreign object.
3. Damage caused by dropping the spray gun or any nozzle component.
4. Damage caused by the use of abrasive materials.
5. The warranty does not cover damages caused by improper handling, normal wear and tear, mechanical damage, faulty assembly, and improper maintenance.

Warranty does include the following:

1. Defects in production parts or material during the 12 month warranty period.

ALL WARRANTY CLAIMS MUST BE RETURNED TO DAN-AM COMPANY HEADQUARTERS